

# Sustainable endoscopy:

Redesigning the polyp trap



Master thesis | Integrated product design | Meike Bloem

**Master thesis**  
**Sustainable endoscopy: Redesigning the polyp trap.**

Meike Bloem  
4649583

Integrated product design  
Delft University of Technology  
Faculty of Industrial Design Engineering

Supervisory team  
Prof. Dr. Ir. Diehl, J.C.  
Ir. Bos, P

# Executive summary

This project aims to reduce the environmental impact of an endoscopic product, the Polyp trap. The polyp trap is a single use device, that is used during endoscopy to catch removed polyps. Endoscopy is a department that has a relatively high reliance on single-use devices. This is one of the reasons why endoscopy has a high carbon footprint. Through observations in hospitals, literature and product research, the context of endoscopy, the polyp trap and other single-use devices are analysed. Additionally, circular frameworks and strategies specific to the medical context were explored, to identify circular opportunities for the polyp trap. A fast-track LCA of the current polyp trap is used to estimate its current environmental impact and analyse how interventions in design, function or material could influence its carbon footprint.

The insights from this research are used to generate ideas aimed at decreasing the polyp traps environmental impact. The resulting idea directions are presented to various healthcare professionals, such as nurses and infection prevention specialists during interviews. During these interviews, opportunities and risks for the redesign are discussed. Insights from the interviews are used to further develop the idea direction into the final design.

The final design consists of two concepts: The first concept is more conceptual, and reduces its impact by using some components for a longer amount of time; one day rather than per patient. The second concept is more traditional, and decreases its CF through minimising the required amount of material, leading to a smaller design that uses lower-impact materials. The environmental footprint of the final concepts is evaluated with a fast-track LCA.

## List of terminology and abbreviations

In this report, several abbreviations of medical terms will be used, to improve the readability. This shortlist will function as a reference for those terms. Any abbreviations present in this report, will be explained on this list.

### Terminology

**Endoscopy** – A minimally invasive procedure where a tube is inserted into the body of a patient used to observe, diagnose and operate on internal organs.

**Polypectomy** – The process of removing a polyp from a patient's internal organs during an endoscopy.

**Bio-based plastic** - Plastics with an organic carbon origin, rather than made from fossil-based resources.

**Bio-degradable plastics** – Plastics that can decompose into water, CO<sub>2</sub>, biomass and bio-nutrients under the influence of microorganisms.

### Abbreviations

SUD	Single-Use Device
HSW	Hospital-specific waste
LCA	Life cycle analysis
CF	Carbon Footprint
PHA	Polyhydroxyalkanoates
HDPE	High-Density Polyethylene
LDPE	Low Density Polyethylene
PET	Polyethylene terephthalate
PU	Polyurethane
PP	Polypropylene
PC	Polycarbonate
PS	Polystyrene
SAN / AS	Styrene-acrylonitrile copolymer
PMMA	Polymethyl methacrylate

# Content

Executive summary	4		
Content	6		
1. Introduction	8		
2. Method	12		
2.1 Scope	12		
2.2 Research questions & method	12		
<b>Part I: Context</b>	<b>15</b>		
3 Endoscopy	16		
3.1 Procedure	16		
3.2 Instruments and devices	20		
3.3 Polypectomy	24		
3.4 Reusable devices and criticality	30		
3.5 Waste streams	30		
3.6 Endoscopy scale in the Netherlands and the population screening program (BVO)	32		
3.7 Conclusion	34		
<b>Part II: The Polyp Trap</b>	<b>39</b>		
4. Polyp Trap	40		
4.1 Evolution of the polyp trap	40		
4.2 Models & Components	42		
4.3 List of requirements and wishes	49		
4.4 Bill Of Materials	52		
4.5 fast-track LCA	54		
<b>Part III: Circular Strategies</b>	<b>69</b>		
5. Circular Strategies	70		
5.1 Circular frameworks	70		
5.2 Circular strategies in the medical context.	70		
5.3 Circular strategies applied to the polyp trap	74		
5.4 Conclusion	82		
<b>Part IV: The Redesign</b>	<b>85</b>		
6. Conceptualisation	86		
		6.1 Interviews	86
		6.2 Prototype tests	92
		<b>7. Detailing</b>	<b>98</b>
		7.1 Design	98
		7.2 Product use	106
		7.3 Fast-track LCA of Concepts	110
		7.4 Cost price	112
		7.5: Discussion	114
		<b>8 Reflection &amp; Acknowledgements</b>	<b>116</b>
		8.1 Reflection	116
		8.2 Acknowledgements	117
		<b>9. References</b>	<b>120</b>
		<b>Appendix</b>	<b>123</b>
		<b>A. Project brief</b>	<b>124</b>
		<b>B. Planning</b>	<b>130</b>
		<b>C. Consent form</b>	<b>132</b>
		C.1 Consent form 1: Observational research	132
		C.2 Consent form 2: Interviews	133
		<b>D. Metadata observations &amp; interviews</b>	<b>134</b>
		<b>E: Sealing part material determination</b>	<b>135</b>
		<b>F. Fast-track LCA</b>	<b>136</b>
		F.1 Input data fast-track LCA	136
		F.2 Fast-track LCA current product	141
		F.3 Alternative polyp traps	151
		F.4 LCAs of concepts	163
		F.5 LCA results	169
		<b>G. Interview questions</b>	<b>174</b>
		G.1 Interview questions nurses	174
		G.2 infection prevention & sterile medical devices	175
		<b>F: Cost price calculations</b>	<b>176</b>



# 1. Introduction

The carbon footprint of the healthcare system in the Netherlands is estimated to be the highest in the world relative to the percentage of its national carbon footprint by Pichler et al. (2019) (see figure 1.1). When comparing the carbon footprint per capita, the Dutch healthcare sector is among the 6<sup>th</sup> highest emitters of carbon dioxide (Pichler et al., 2019). This research is based on a top-down analysis, combining national expenditure data, and information from the supply chain database EORA. It shows the significant impact of the Dutch healthcare system on its total carbon footprint and provides an estimated comparison to other countries. However, no in-depth information on the factors contributing to this Carbon Footprint is provided. Research from Steenmeijer et al. (2022) shows a more

detailed exploration of the environmental impact of the Dutch healthcare system. It shows that material extraction causes the main share of the environmental footprint with 13%, followed by blue water consumption, the amount of surface or groundwater that is consumed, with 7.5%. CO2 emissions are the third highest share, with 7.3%. Further research about the determinants of this carbon footprint and their influence, or the impact of specific sectors within the Dutch healthcare system, has not yet been conducted. Therefore the amount of concrete information on how to decrease the environmental impact for the healthcare system, for a hospital, and especially for a specific department is limited.

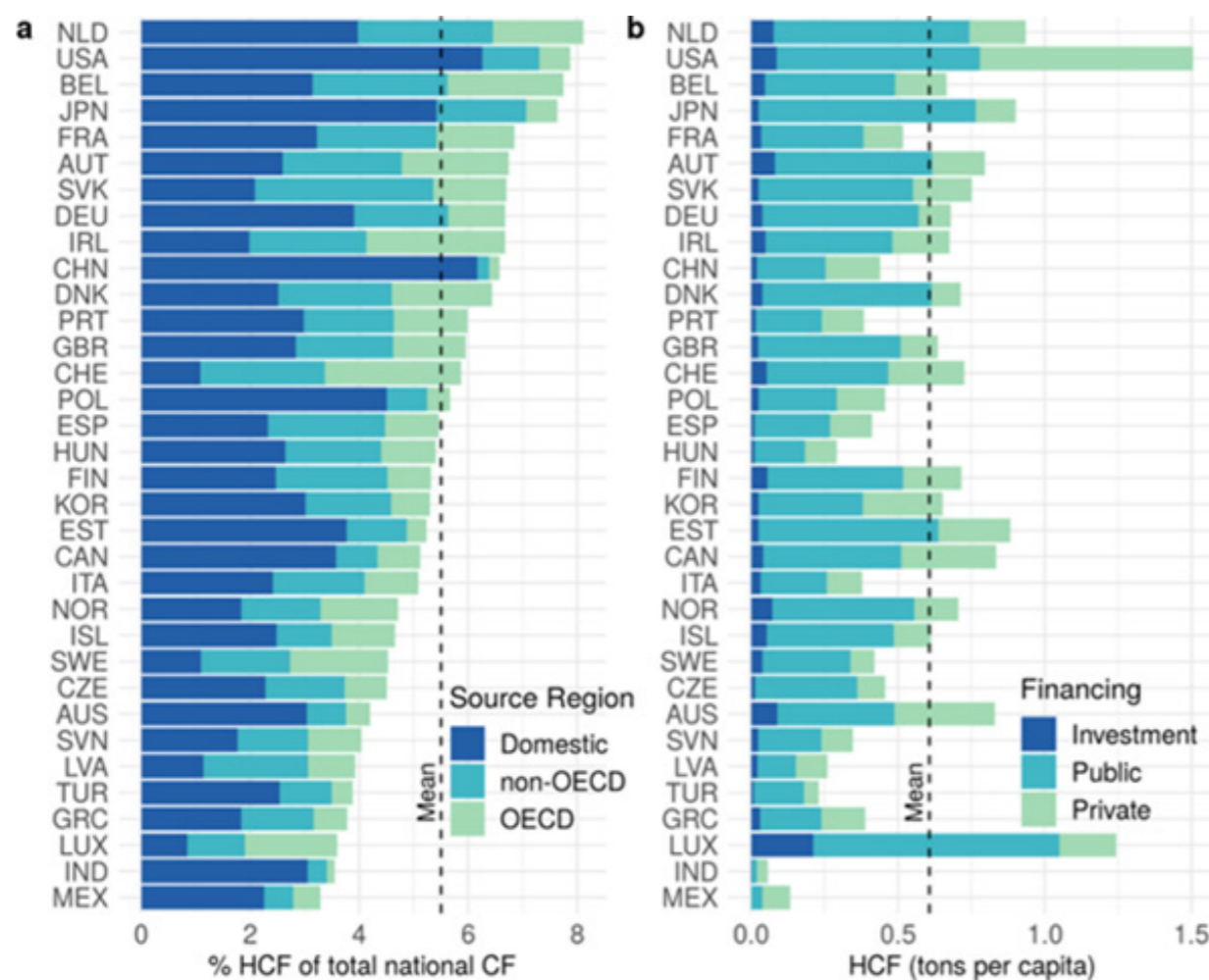

Figure 1.1: Health Carbon Footprint as a percentage of national Carbon Footprint (Pichler et al., 2019).

Within the healthcare setting, endoscopy is considered to be a significant contributor to the carbon footprint and environmental footprint (Maurice et al., 2020). Its carbon footprint is estimated to be about 85,768 metric tons of CO2 emissions annually in the USA alone (Siau et al., 2021). A main contributor to this carbon footprint is waste generation. Within the healthcare system, endoscopy is estimated to be the third largest waste generator (Siau et al., 2021). An average endoscopy department in the USA generates about 3.09 kg of waste per bed per day (Maurice et al., 2020). Other factors that Maurice et al., (2020) find to be contributing to endoscopy's high environmental footprint are decontamination processes using large amounts of water, energy, and chemicals and an increased reliance on single-use devices combined with a high frequency of procedures. Most of these single-use devices are not recycled and will thus be incinerated (Siau et al., 2021). Furthermore, companies producing and supplying endoscopic devices and products are still moving away from multi-use devices and towards single-use devices (De Melo et al., 2021). Therefore, the amount of waste generated by endoscopic surgeries is still growing.

As of yet, there is a lack of concrete data about factors such as departmental energy use and reusable devices compared to single-use devices. Researchers suggest that the environmental impact of endoscopic procedures and activities should be analysed to design interventions that could decrease the environmental impact (Maurice et al., 2020). Research on this topic within the Dutch context is even more limited. No life cycle analyses about endoscopy in Dutch hospitals have been made (public). Still, parallel insights seem to be present, as single-use plastics are recognized by medical professionals to be a substantial problem in the Dutch healthcare system (Bijlsma, 2020). Additionally, the factors found to be contributing to endoscopy's high environmental footprint by Maurice et al., (2020) correspond with the factors that Steenmeijer et al., (2022) determine to be the main contributors to the environmental footprint of the Dutch healthcare system. The reliance on single-use

devices contributes to both the main share; material extraction and the fourth largest share; waste production. Decontamination processes correspond with blue water consumption, the second largest share and its energy use with climate change, the third highest share.

To conclude, research suggests that endoscopy in the Netherlands could be a large contributor to the healthcare sector's carbon footprint and environmental footprint. However, research on the environmental impact of the Dutch healthcare system is scarcely available, mainly top-down, and unspecific to the specific factors contributing to this impact. To be able to effectively adapt the healthcare sector in a carbon-neutral and circular way, more research is required to determine what factors are the main contributors to the sector's environmental impact. In the meantime, international research can be used to start working on a transition to a circular healthcare sector. Furthermore, a bottom-up approach can be used to harness the expertise of healthcare professionals to design interventions in their specific fields of expertise. In. This brings me to the research group behind this graduation project.

A research group at Hogeschool Windesheim has initiated the project "Weggoeien? ons een zorg!" To explore which innovations in products, processes, information technology and business models could contribute to a more circular healthcare system in the Netherlands. The research group is collaborating with multiple hospitals, such as the Isala Hospital in Zwolle, and several companies specialising in medical products providing graduation cases for several students at Hogeschool Windesheim and other universities. The companies that are associated with this specific project, are Meditec and H&P Moulding. Through the connections from Meditec, healthcare professionals from endoscopy departments at other hospitals and clinics, such as Groene Hart Ziekenhuis and ACIBADEM International Medical Center are involved in observations and interviews (see figure 1.2 for stakeholder visualisation).

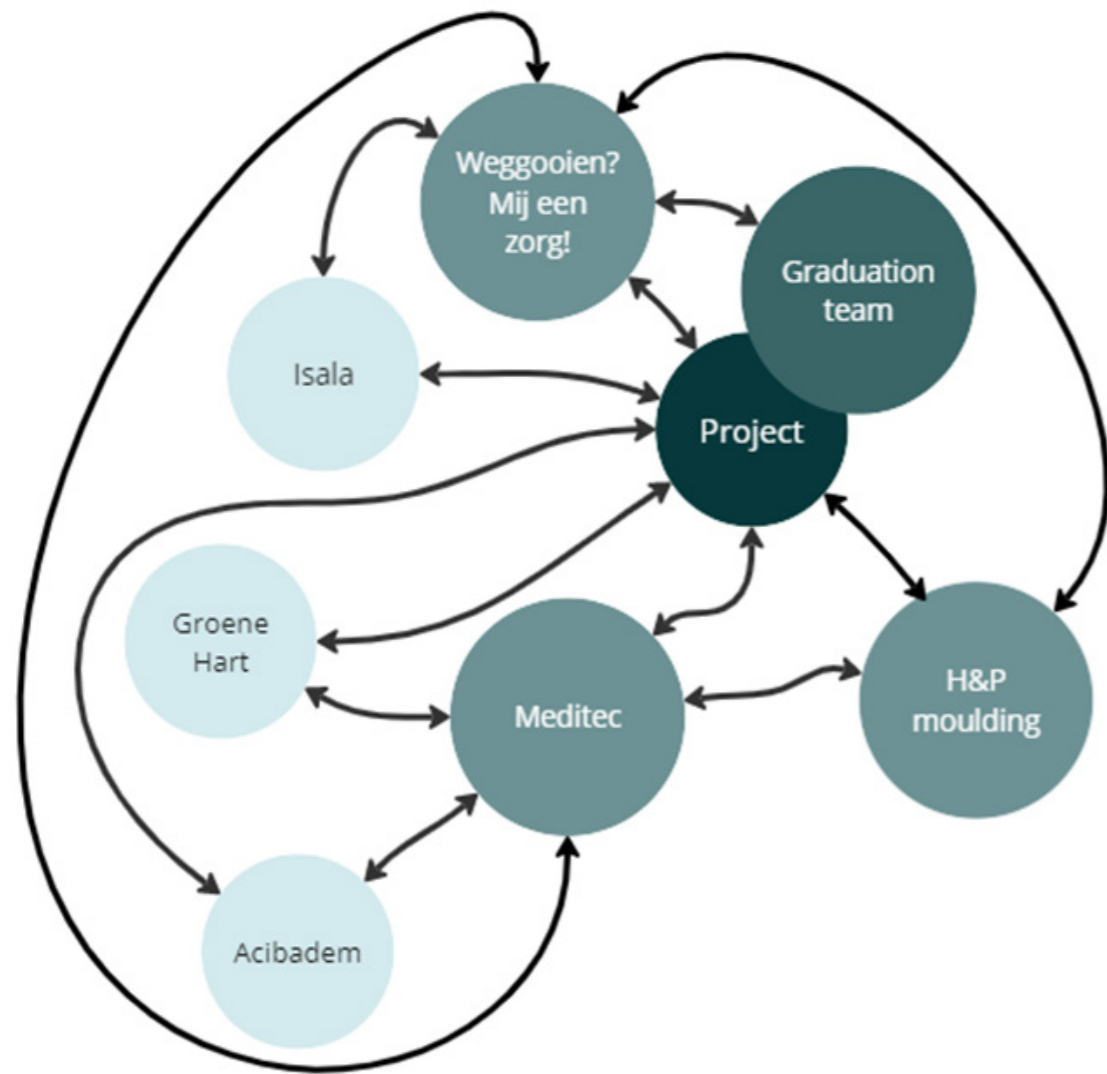

Figure 1.2: Stakeholders.

Meditec is a supplier of single use medical products, mainly specialised in endoscopic supplies. They are in the process of becoming a producer as well as a supplier, producing their products locally rather than sourcing products overseas. They recognise the need to move to a more sustainable healthcare system and would like to explore how they can adapt their envisioned products to be more sustainable. Meditec and H&P moulding work together to realise a new production line of endoscopic products, including the polyp trap. They aim to decrease the environmental impact of their

products compared to the alternatives currently in the market. Additionally, H&P Moulding has developed experience in injection moulding of PHA, a bio-based, and bio-degradable material. They are interested in the ways that this innovative material can be used to design more circular medical products. One of the products that Meditec and H&P moulding plan to produce, is the polyp trap (see figure 1.3). During this project, I will use the polyp trap as a case study on how to redesign a single-use product more sustainably.



Figure 1.3: A polyp trap.

Polyp traps are used to collect polyps during endoscopic surgeries. During an endoscopy, doctors use an endoscope, a medical device equipped with a camera, to look inside a patient's body. The polyp trap is connected to the endoscope. The endoscope uses suction to transport polyp tissue from the patient's intestines to the polyp trap. This enables medical professionals to separately contain polyps for analysis in the lab. Opportunities for redesigning single-use

products such as the polyp trap, could be in redesigning the product and its packaging at a concept level, rethinking its functionality, and the way it is used. To redesign the polyp trap as a sustainable product, its current environmental impact needs to be determined. From there, different circular strategies can be considered and more sustainable alternatives can be developed.



# 2. Method

In this chapter, the scope of the project will be defined. Furthermore, the structure of the report will be explained, and the research questions will be introduced. Finally, the methods and activities that will be used to answer the research questions will be described.

## 2.1 Scope

The focus of this project is on the polypectomy, the products used during this procedure and the impact of the waste stream they create. A polypectomy is an endoscopic procedure, where an abnormal tissue growth in the lining of an intestine is removed, and preserved for analysis.

## 2.2 Research questions & method

The report is structured in four parts; Part I: Context; Part II: The polyp trap; Part III: Circular strategies and Part IV: Redesign. In each part, one of the following research questions and its sub-questions is answered. In appendix B, the overall planning for this project is visualised.

### 1. How could a design intervention in the process of the polypectomy lead to a reduction in environmental impact?

- What does the process of a polypectomy, and the use of a polyp trap look like?
- Where in this process could a design intervention lead to a reduction of the environmental impact?
- What are the requirements that are relevant to the polyp trap?
- Which healthcare professionals are stakeholders in the process of endoscopy and polypectomy?
- What stakeholders could influence the environmental impact of the polyp trap and polypectomy?
- What other devices and SUD are used during a polypectomy, and how do they interact with the polyp trap?
- Could a design intervention in the (interaction between) SUD used during polypectomy lead to a reduction in environmental impact?

### 2. What is the current environmental impact of the polyp trap?

- How can the environmental impact of the polyp trap be defined? What type of environmental harm does the polyp trap cause?
- What is the current environmental impact of the polyp trap polypectomy on a yearly base in the Netherlands?

### 3. How can circular strategies be used to redesign medical SUD such as the polyp trap in a more sustainable way?

- How can existing circular frameworks be used to outline potential circular strategies for the context of medical SUD?
- How could these circular strategies be applied to the polyp trap?

### 4. How can the polyp trap be designed in a more sustainable, yet feasible and viable way?

- How would applying different circular strategies to the current polyp influence the environmental impact of the polyp trap?
- What is the difference in environmental impact between the current polyp trap, and the redesign of the polyp trap?
- How would the redesign influence the price of the polyp trap?
- How would the redesign of the polyp trap influence the polypectomy procedure for varying healthcare professionals?
- How would the redesign of the polyp trap influence logistics in a hospital?

In part 1. Context, I will analyse through observations in hospitals how endoscopy and polypectomy specifically work, what other SUDs are used during this procedure, and how the polyp trap is used. Additionally, I will analyse how the product moves through the hospital logistically, and which healthcare professionals work with the product, influence it, or are influenced by it in some way. From these insights, I will create a list of requirements for the redesign of the polyp trap. As a conclusion, I will identify areas of opportunity within the product, its use, stakeholders, or logistical system, where a design intervention could potentially lower the environmental impact of the product. In the second part, The polyp trap, I will focus on the current product, and analyse its current environmental impact through a fast-track lifecycle analysis (LCA). The results of this fast-track LCA will be used to identify what aspects of the product have the largest CO2 footprint. These insights will be used in the redesign of the product. Additionally, the fast-track LCA functions as a benchmark to compare the redesigned concept to the current product.

In part 3: Circular strategies, I will identify a suitable framework that defines circular strategies for the medical through literature research. Through this literature research, I will explore varying circular strategies,

how they are currently used in the medical context and how they could be applied to the polyp trap. I will describe the implications of the use of the product, the logistical system surrounding it, and the potential risks associated with applying each strategy. I will conclude with a set of circular strategies that would be suitable for the redesign of the polyp trap.

In part four, Redesign, the insights, conclusions and requirements gathered during part one to three, will be used to redesign the polyp trap more sustainably. This redesign will be created through ideation and interviews with healthcare professionals. I will evaluate the usability, feasibility and viability of the redesign through various prototypes and interviews with healthcare professionals. Possible results of this re-design could be a different concept that replaces the polyp trap, making it obsolete, or combining it with other product functionalities used in endoscopic surgeries; A redesign of the polyp trap that enables it to be sterilised and reused or recycled; A redesign of the polyp trap specifically tailored to reduce its weight, or to the use of bio-based or bio-degradable materials.

*In Part I, research question one will be explored:*

1. How could a design intervention in the process of the polypectomy lead to a reduction in environmental impact?
  - a. What does the process of a polypectomy, and the use of a polyp trap look like?
  - b. Where in this process could a design intervention lead to a reduction of the environmental impact?
  - c. What are the requirements that are relevant to the polyp trap?
  - d. Which healthcare professionals are stakeholders in the process of endoscopy and polypectomy?
  - e. What stakeholders could influence the environmental impact of the polyp trap and polypectomy?
  - f. What other devices and SUD are used during a polypectomy, and how do they interact with the polyp trap?
  - g. Could a design intervention in the (interaction between) SUD used during polypectomy lead to a reduction in environmental impact?

*Through observations in two different hospitals and literature research, the context of the polyp trap, the endoscopy department will be explored. The process of endoscopy and polypectomy will be explained, the healthcare professionals involved in these processes will be introduced, and their roles will be explained. The instruments and devices used during endoscopy will be introduced and their use and interactions with healthcare professionals and other devices will be explained. Additionally, their lifetime and end of life will be explained. Lastly, the scale and function of endoscopy in the Dutch context will be reviewed. Information gathered from observational research will be referred to anonymously through participant numbers in the form 'Pn'. The metadata table that provides information about each participant can be found in appendix D.*



# 3 Endoscopy

## 3.1 Procedure

Endoscopy is a non-surgical procedure. During an endoscopy, the patient's digestive tract is inspected, using an endoscope. The endoscope is a device, with a flexible and steerable insertion tube, equipped with a light and camera, which outputs live video footage (see figure 3.1.1). The insertion tube is built up of an overlapping steel mesh and spiral, that can be rotated concerning each other to adapt the stiffness of the tube. The endoscope can be steered through angulation wires running through the tube. Furthermore, the tube contains signal wires connecting to the lights and camera, a water jet channel for cleaning the environment, an air channel to insert CO<sub>2</sub>, which holds open the intestine (the water jet and air channel can also be combined), a water droplet channel used to clean the camera lens and improve visibility, and the biopsy channel (see figure 3.1.2). The camera, lights and openings to the water, air and biopsy channel are positioned on the distal tip of the endoscope (see figure 3.1.3).

The endoscope processor connects the endoscope to all other equipment used during an endoscopy, such as the monitors and the pump system (figure 3.1.4). During an endoscopy, a doctor inserts the endoscope tube into either the patient's mouth, through the throat to examine the oesophagus, the stomach and the upper part of the small intestine, or through the rectum to examine the large intestine (WebMD Editorial Contributors, 2021). The video footage of the endoscope, is visible on several monitors, and the surgeon manoeuvres the endoscope with knobs and buttons, while a nurse inserts the endoscope further, or pulls it back when required. Through the biopsy valve or instrument channel, instruments can be inserted in the patient's intestines through the biopsy channel (see figure 3.1.5). The

endoscope is connected to a pump system, that can administer sterile water to flush the environment or the endoscope camera, or CO<sub>2</sub> to keep the intestine inflated. The use of CO<sub>2</sub> has replaced the practice of using ambient air because CO<sub>2</sub> is absorbed more easily by the human body. This makes recovery more comfortable for the patient.

The surgeon operates the pump system with foot pedals. Waste water is transported through the suction channel of the endoscope, and the irrigation system, into a waste water bag positioned in a vacuum container. The endoscopy setup is visualised in figure 3.1.4.

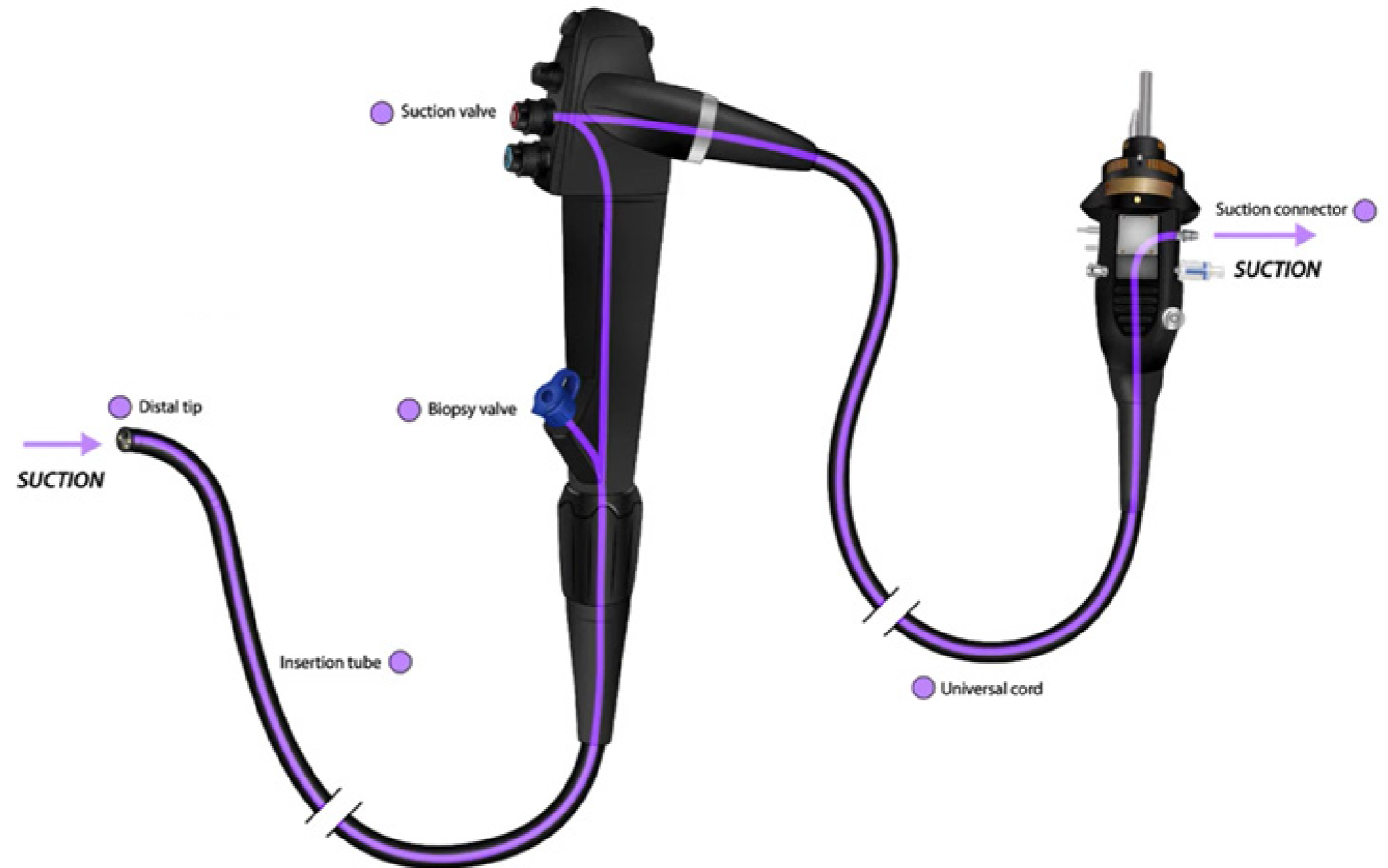

Figure 3.1.1: An endoscope (Raju, 2022).



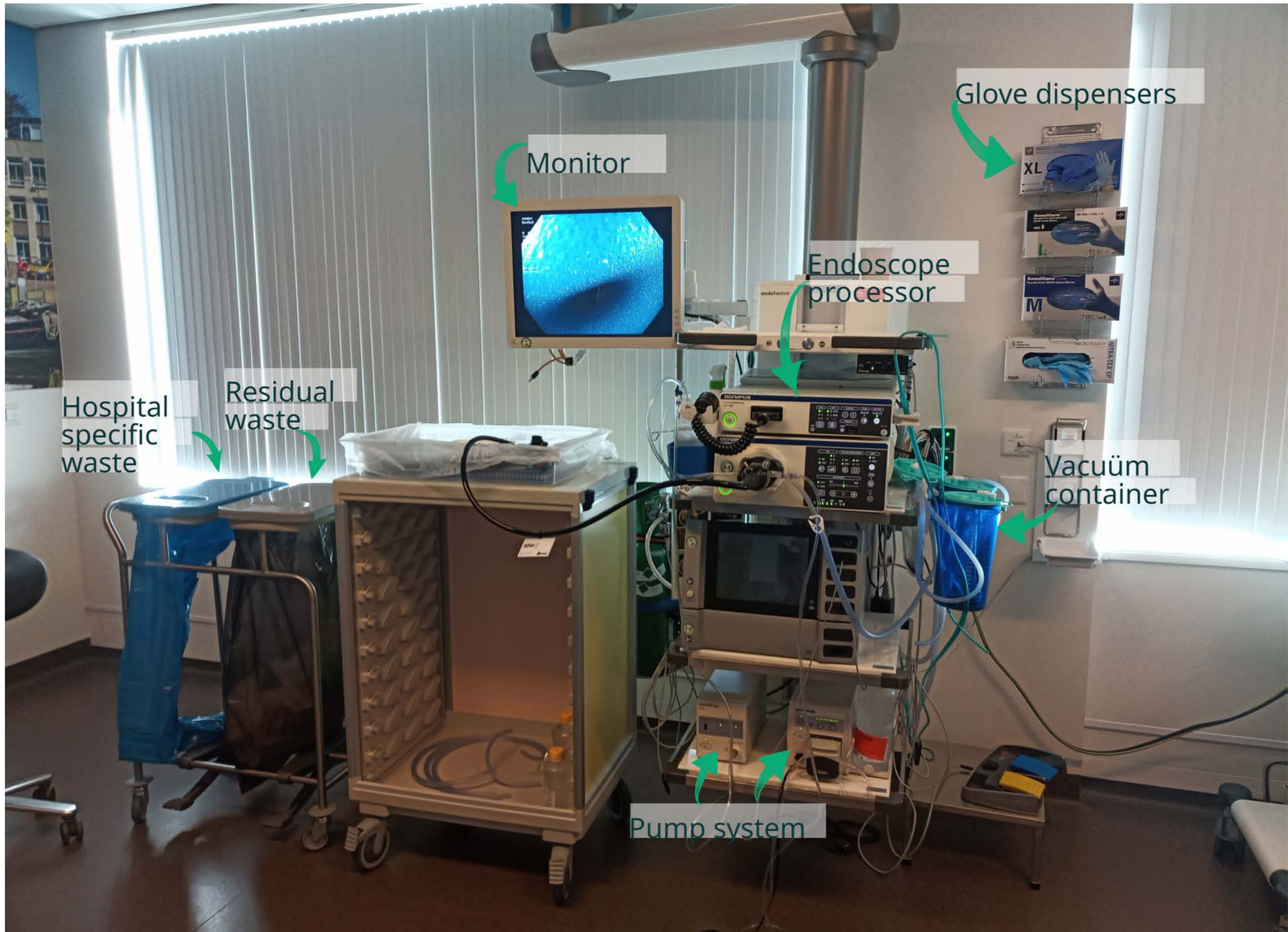

Figure 3.1.4: Endoscopy setup



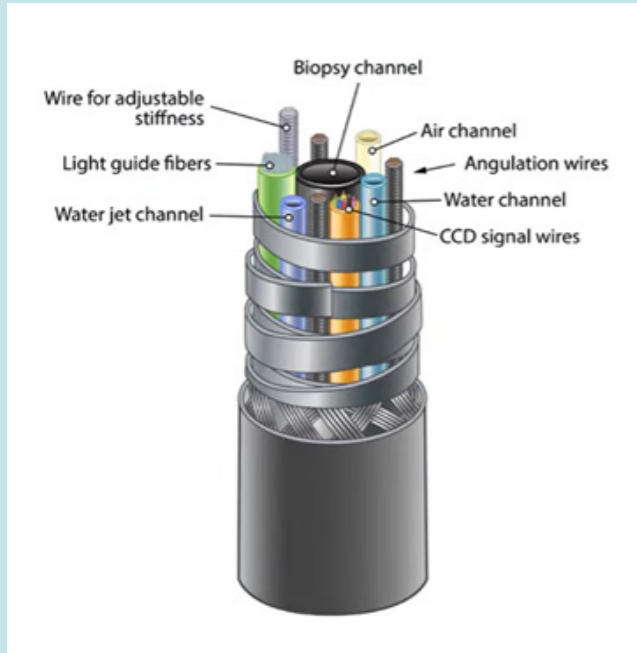

Figure 3.1.2: cross section of the insertion tube of an endoscope (Raju, 2022).

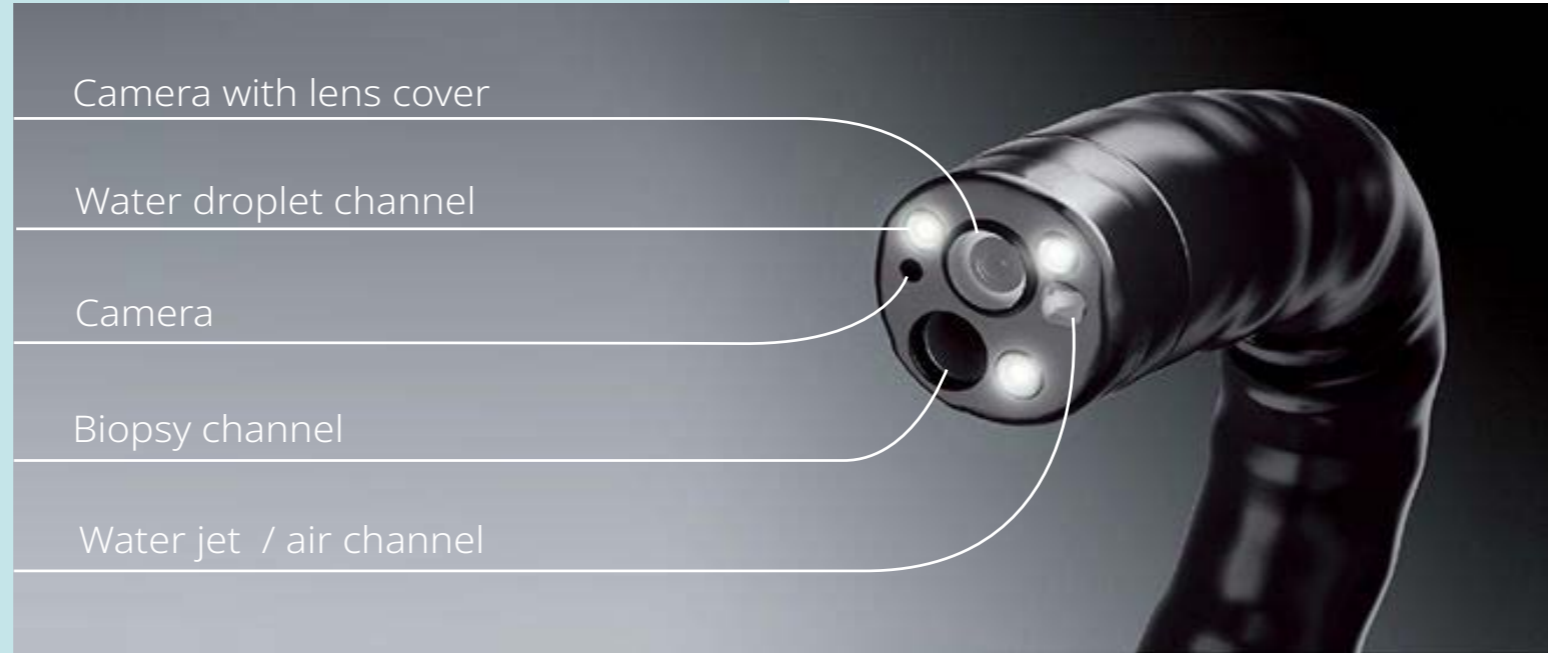

Figure 3.1.3: Distal tip of the endoscope (Nippon, (2013); adapted).



Figure 3.1.5: biopsy forceps protruding from the instrument channel of the distal tip of an endoscope.

Typically, the endoscope is inserted onto the final point of inspection. For a standard colonoscopy, this would be the start of the small intestine. The inspection takes place on the way back from this point. The surgeon and nurse watch out for polyps, tumours, and other anomalies. During this process, polyps are removed, which is called a polypectomy (P3, see Appendix D). The surgeon can also take pictures, or mark areas where a polyp has been removed with a small tattoo, a blue dot, for later reference (P8, see Appendix D).

### 3.2 Instruments and devices

There are various tools and instruments that are used during endoscopy, of which some are reusable, such as the endoscope (see figure 3.2.1-3.1.4). Reusable products, such as the endoscope, are thoroughly cleaned and decontaminated and used for another patient. This process is called reprocessing. Many other instruments and devices are disposed of after a single-use cycle. These are called single-use devices, from here on referred to as SUD.

The lifetime and end of life of different SUD

vary greatly. Some SUD, such as aprons, or gloves are used per patient. Others are used only once, until their specific function has been fulfilled. For an injection needle, its function is fulfilled almost immediately as its use is initiated, after one injection. In contrast, a wastewater bag has fulfilled its function when it is full of flushed water and bodily fluids, and can therefore be used for multiple patients over a period of multiple hours. Lastly, there are SUD that are used for a specific time periods, often 24 hours, or a week. Examples of such products are CO2 and sterile water tubes. The duration of these periods can vary depending on the specific protocols of departments in hospitals, and is determined by infection prevention personnel of that specific department and hospital.

All SUD come in individual packaging, which depending on the function of the SUD, can be sterile or non-sterile. The packaging of SUD is disposed of immediately after its unwrapping. (P3; P7; P7, see appendix D). To create more insight into the varying lifetimes of this SUD, I designed icons to categorise them. These icons are visualised in figure 3.5.5 and will be used throughout this report to categorise varying devices and concepts.

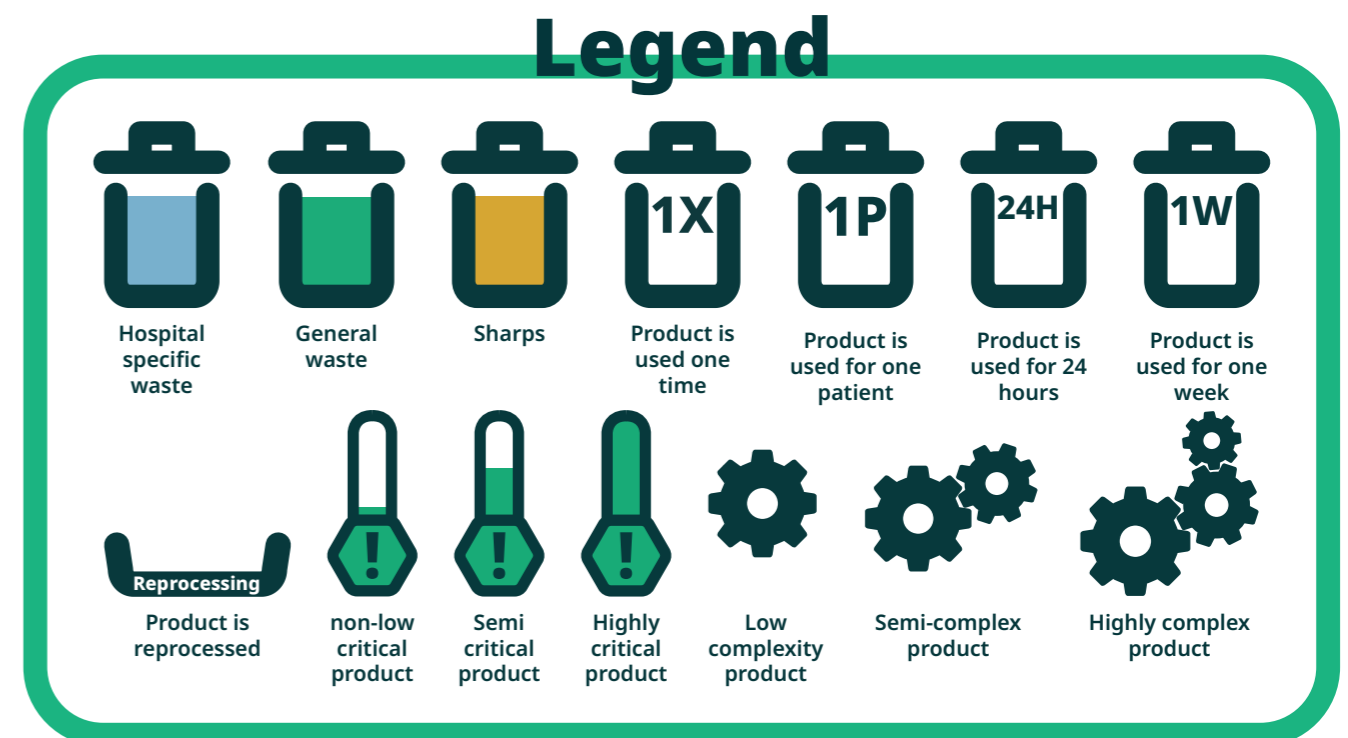

Figure 3.5.5: Medical devices categorising icon legend.





Figure 3.5.5: Medical devices categorising icon legend.

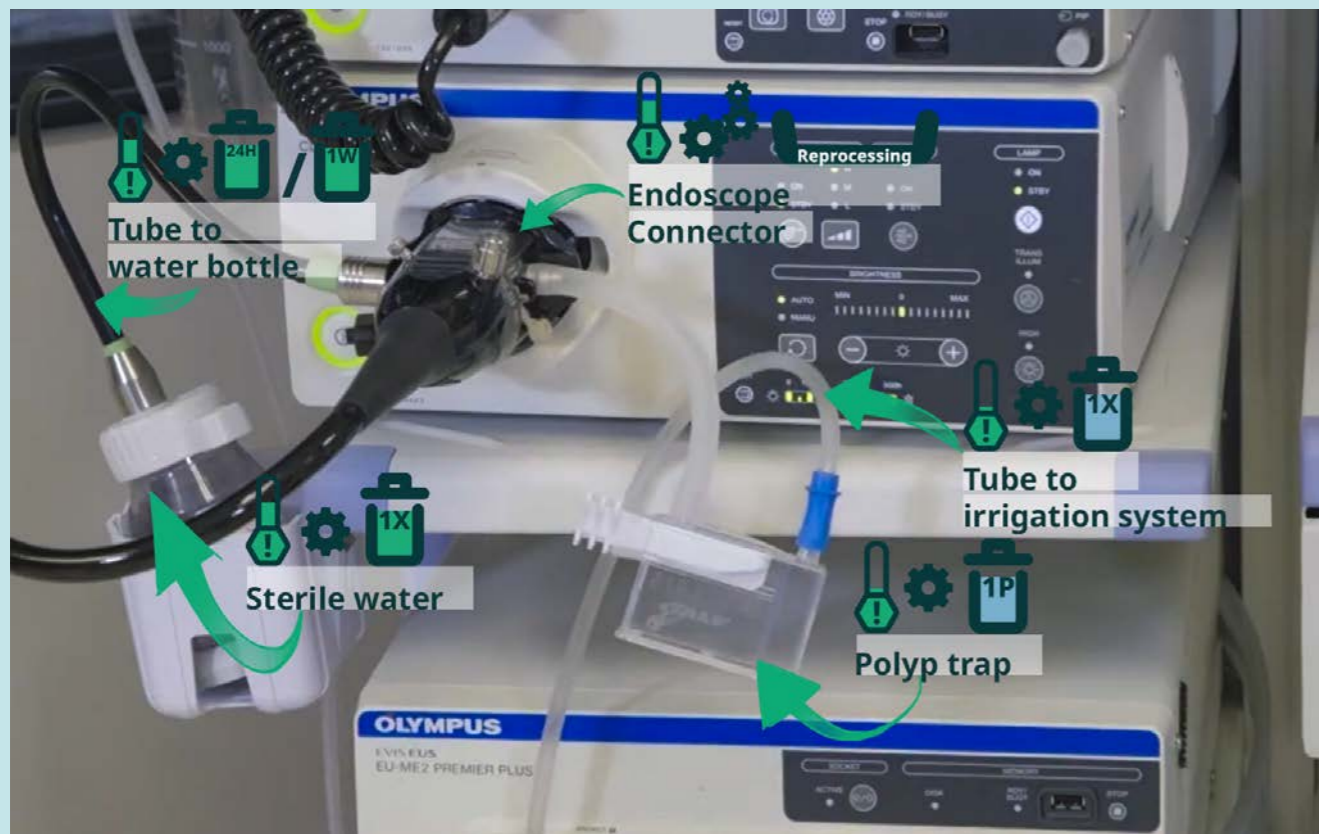

Figure 3.5.6: Polyp trap connected to endoscope.



Figure 3.2.2: Products used to protect nurses, surgeon and patient during an endoscopy.

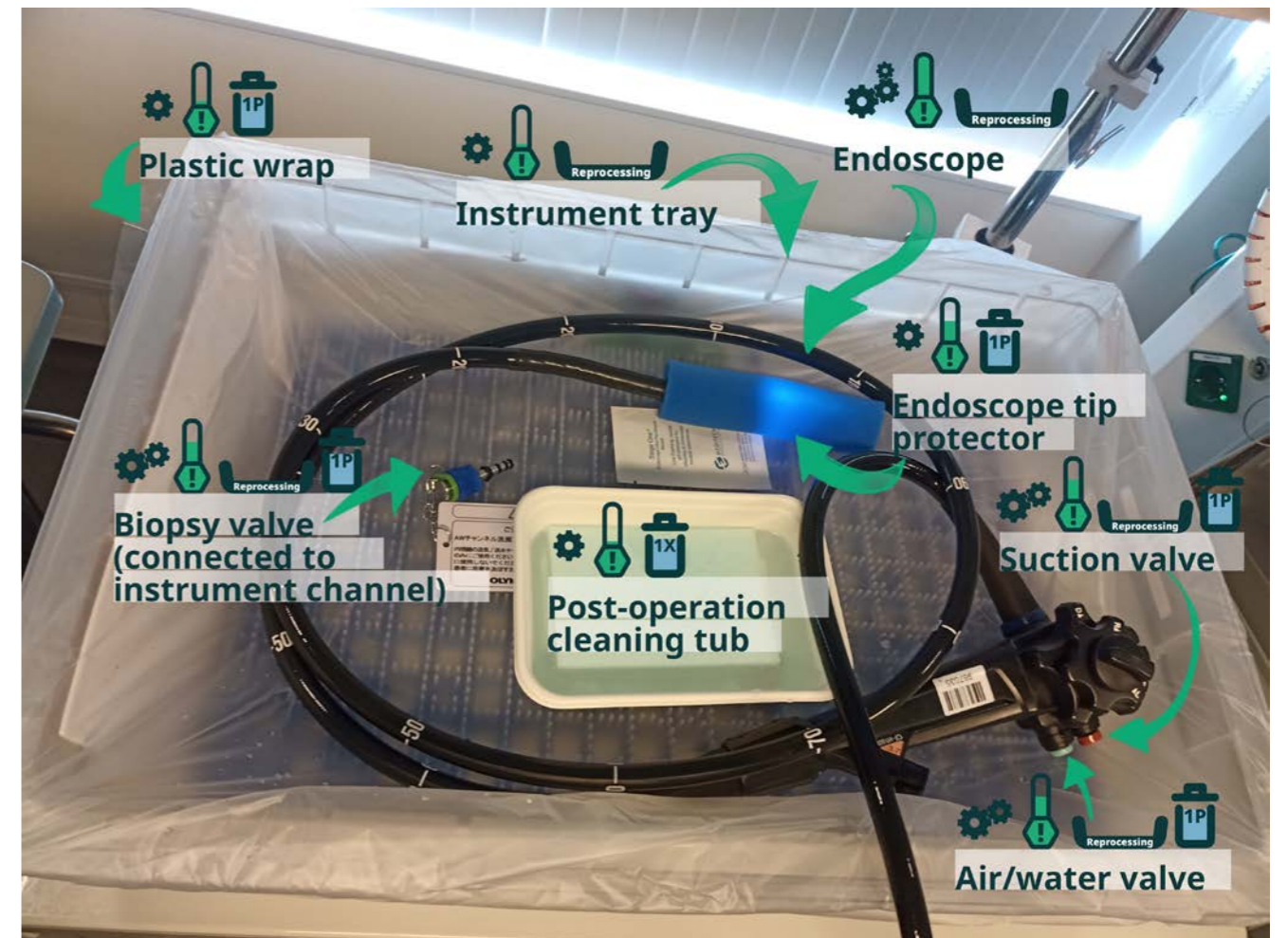

Figure 3.2.3: Products surrounding the endoscope.



### 3.3 Polypectomy

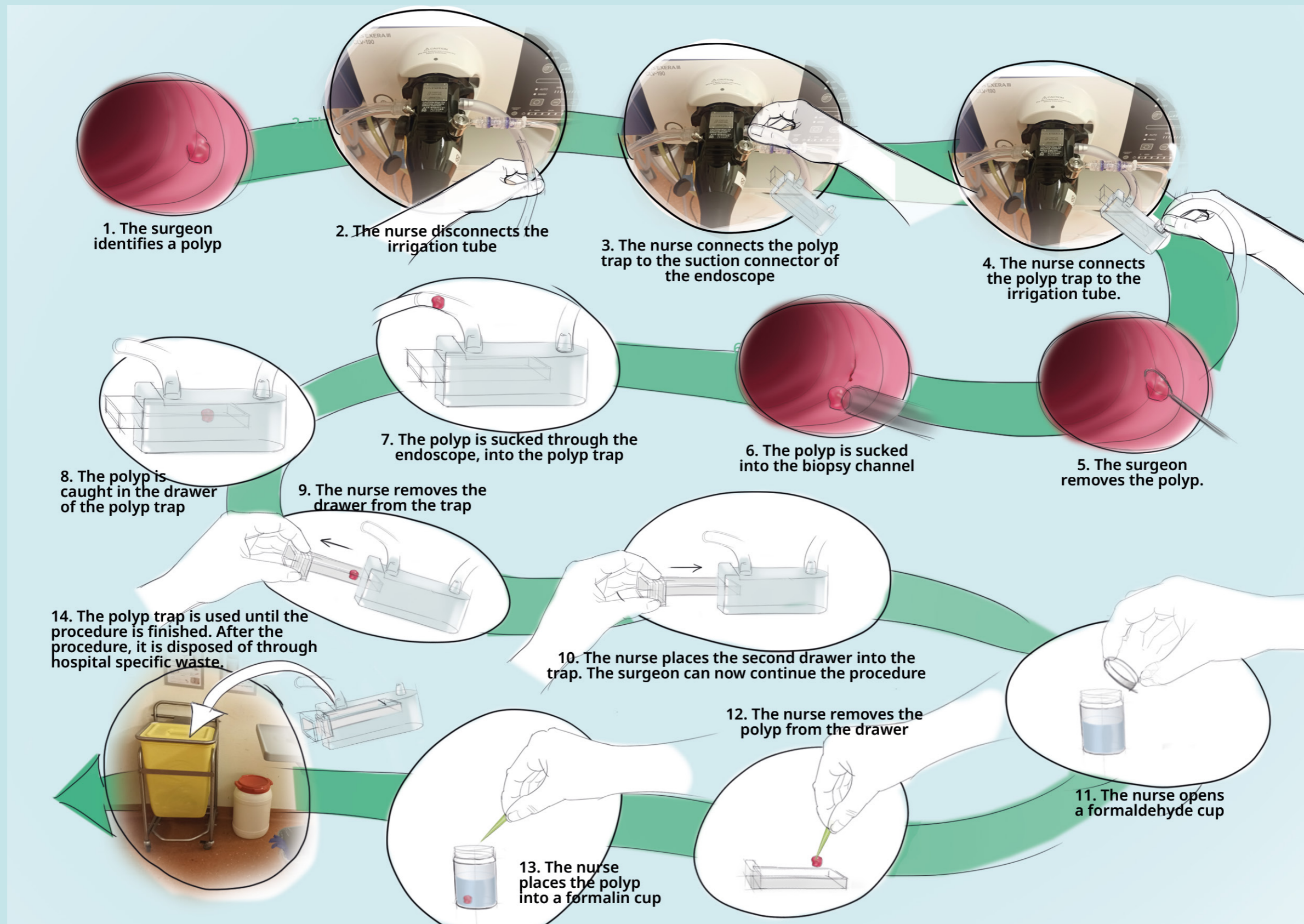

Figure 3.3.1: Polypectomy process.



Polyps are normally removed out of precaution, as they can grow into tumours. This process, visualised in figure 3.3.1 is called a polypectomy. The polypectomy snare (see figure 3.3.2) is an instrument that is often used to remove polyps. The nurse inserts it through the instrument channel of the endoscope. The surgeon positions the snare around a polyp, and the nurse rapidly closes it by pulling the handle, snipping off the polyp. Polyps grow in many different variations in shape and size, resulting in many different variations of the snare, in different sizes and shapes and with additional functionalities each more suitable for a certain type of polyp. A variation often used for larger polyps, or polyps that contain a relatively large vein, is the hot snare. This snare burns through the tissue to prevent increased blood loss. Additional instruments that are often used in the process of removing polyps are biopsy forceps (see figure 3.3.3), tridents, injection needles, and various instruments that can place clips to stop bleeding. As surgeons and nurses never know what to expect, these

instruments are stocked in the operating room and retrieved whenever they are required, rather than laid out before the procedure. All of the instruments that are used through the endoscope's instrument channel, are SUD.

Once a polyp has been removed, it is typically caught in a polyp trap. The polyp trap is placed in between the suction channel of the endoscope and the irrigation tube whenever a polyp is found, and catches the polyp without hindering the air or water flow. The polyp is caught in a drawer, that is immediately replaced with an empty drawer. Before removing the drawer, the nurse checks through the window whether the polyp has completely entered the drawer. After replacing the drawer, the nurse places the polyp into a cup, pre-filled with formalin, a fixating solution that preserves the tissue (see figure 3.3.4). The order of removal is noted on the lid of the cup, and the location of removal of the polyp is noted after the procedure. After the procedure, the polyp trap and its drawers are



Figure 3.3.2: Polypectomy snares.

disposed of (see figure 3.3.6 for the product journey of the polyp trap). The formalin cup(s) containing polyps are stored in a fridge until stretcher bearers transport it to the hospital's laboratory, where a pathologist anatomist analyses the tissue for cancerous cells. Formalin cups come in various sizes, but generally, 50 mL cups are used (P7, see Appendix D). Most polyps are the size of a pinhead. However, they can be up to several centimetres in diameter. These larger polyps cannot enter the biopsy channel and are



Figure 3.3.3: Biopsy forceps.

therefore not retrieved with the polyp trap. In this case, a polyp retrieval net can be used (see figure 3.3.6). Other times, the surgeon will use biopsy forceps (see figure 3.3.3) to grasp and retrieve the polyp. For the removal and analysis of a single polyp, a bundle of cells of often as small as a pinhead, at least three products are used, containing about ten different materials. For further elaboration on materials used in the polyp trap and formalin containers, see Chapter 4.5: LCA.



Figure 3.3.4: Prefilled formalin cups in a drawer.



Figure 3.3.5: Polyp retrieval nets.

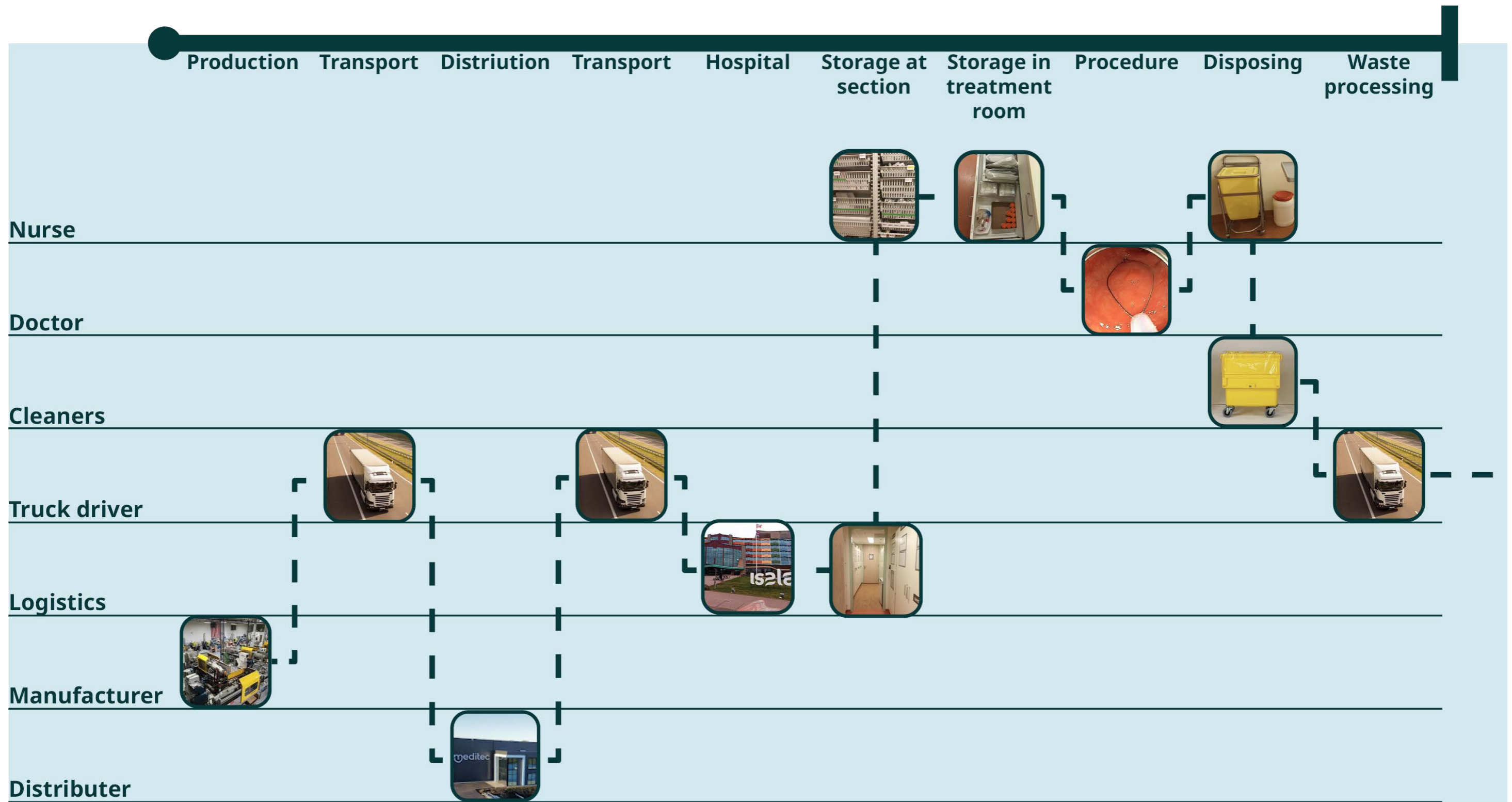

Figure 3.3.6: Product journey of a polyp trap



### 3.4 Reusable devices and criticality

As discussed in Chapter 3.2, most endoscopes are reusable. One factor that is unique to the medical sector, is the need for disinfection and sterilisation before re-use, and the strict rules and regulations that apply to prevent the spread of infectious diseases. This process is called reprocessing. Reprocessing often happens in the hospital, but external reprocessing companies also exist (Kane et al., 2018). The reprocessing process can differ greatly from product to product, depending on its function and working principle. However, the Spaulding classification system, which originated in 1957 is still commonly used to design disinfection and sterilisation protocols (Rowan et al., 2023). The Spaulding system categorises risk at three levels of decontamination; critical use, semi-critical use, and non-critical use (Spaulding, 1968). However, it is also used to categorise medical instruments and devices, both reusables and SUD to define regulations

and protocols (Rowan et al., 2023). The first category; critical use, defines products that enter sterile tissue, and must therefore be sterile (Spaulding, 1968). Sterilisation is the process of eliminating all microorganisms, and spores of organisms (McKeen, 2012). In the context of an endoscopy, products such as snares or injection needles are categorised as critical use devices. The second category; semi-critical use, defines devices that come into contact with mucous membranes or damaged skin, and must at least receive a high-level disinfection (Spaulding, 1968). The disinfection process eliminates or reduces microorganisms (McKeen, 2012). The endoscope itself falls into this category. The last category; non-critical use, defines products that only interact with intact skin, and therefore require low-to-intermediate level disinfection (Spaulding, 1968), such as anaesthesia masks, or polyp traps.

### 3.5 Waste streams

#### Collection

There are generally three different waste streams in an endoscopy room. General waste, hospital specific waste, and sharps. General waste is disposed of in bags, and hospital-specific waste is disposed of in either bags (see figure 3.5.1) or in containers (see figure 3.5.2). Sharps are always collected in a specific hard yellow container with a red lid (see figure 3.5.3). The container prevents any further direct interaction with its contents; hospital-specific waste with a high infection risk. General waste contains waste that has not come into contact with the patient, or any bodily liquids or tissue from the patient. This waste stream is mainly used for packaging materials. According to Dutch guidelines regarding waste processing, general waste originating from hospitals should be incinerated (Rijkswaterstaat, 2021). However, hospitals can arrange with their waste processors, to recycle specific parts of this waste stream, such as paper, or (clean)

plastic packaging materials (Milieu Service Nederland, 2023).

Hospital-specific waste contains any waste that has come into contact with the patient, or their bodily fluids or tissue. The polyp trap should be disposed of through this waste stream. The waste bag or container with hospital-specific waste and the sharps containers are collected from the operation room and stored into larger containers (see figure 3.5.4) before a waste collection company transports these containers to the waste treatment facility (P2; P3; P7, see appendix D) (Milieu Service Nederland, 2023).

To create insight into the different waste streams, I created the icons displayed in figure 3.5.5. These icons will be used throughout the report to categorise the waste streams of varying medical instruments and devices.

#### Processing

Dutch regulations on waste processing require all hospital-specific waste, has to be incinerated in a specialised waste processing facility (Rijkswaterstaat, 2021)(Milieu Service Nederland, 2023). These specialised waste treatment facilities incinerate hospital specific waste including the container used for collection. Therefore, these containers

could also be seen as SUD. The waste stream is incinerated at a higher temperature compared to general waste, to mitigate the risk of residual pathogens. Therefore, the energy consumption for incineration of hospital specific waste is higher relative to general waste incineration. It is unclear what this difference in energy consumption is, what amount of energy is recovered, and how much CO<sub>2</sub> is expelled in the process.



Figure 3.5.1: Hospital specific waste and general waste collection bags (respectively).



Figure 3.5.2: Hospital specific waste container in operation room.



Figure 3.5.3: Sharps container in operation room.



Figure 3.5.4: Collection of hospital specific waste containers by waste collection company GP Groot at Dijklander Ziekenhuis (2020).



### 3.6 Endoscopy scale in the Netherlands and the population screening program (BVO)

One of the reasons why endoscopy have a relatively high carbon footprint, is the high number of procedures, due to a focus on preventative care. Although there is no information available on the total annual number of endoscopies in the Netherlands, The population screening program or bevolkingsonderzoek (BVO) could indicate the scale of number of annual procedures. The BVO aims to identify colon cancer in an early stage. Every citizen, from 55-75 is invited to participate in the population screening, through an envelope that contains a tube, through which participants can send in some of their stool (see figure 3.6.1). This is analysed for the presence of blood. If blood is found, participants are invited to a colonoscopy. The participation rate has been declining over the period from 2018-2021. However, in 2021, it was still relatively high, at 70.6% in 2021. Of the 1.6 million participants, 3.8% received a request for a follow-up examination. About 62.000 people agreed to participate and underwent a colonoscopy. This resulted in 2.790 tumours found, and 16.878 advanced polyps (Integraal Kankercentrum Nederland, 2021) (see figure 3.6.2). The colonoscopies performed as a result of the BVO take place at hospitals all over the Netherlands. For the two hospitals I visited during my observations, 43% and 19.5% of colonoscopies they performed were part of the BVO. The resulting colonoscopies occurred after a regular referral from a physician (Personal communication, 2023).

Although colonoscopies make up a relatively large share of endoscopies, not all endoscopies are colonoscopies. In the Groene Hart Ziekenhuis, about 59% percent of all endoscopies are colonoscopies (see figure 3.6.3). A rough estimation of the total number of endoscopies in the Netherlands, using the data mentioned from the BVO program, would lead to the BVO colonoscopies being 31.3% of all endoscopies in the Netherlands, resulting in a total annual number of about 200.000 procedures. However, more data is required to make a more reliable estimation.

According to data from the Groene Hart Ziekenhuis, polyps are found in about one out of two colonoscopies. Assuming this percentage is similar for other endoscopies, this leads to a rough estimation of 96.000 polyp traps used annually in the Netherlands (see figure 3.6.4). For an endoscopy where polyps are found, the average number of polyps found in the Groene Hart Ziekenhuis is 3.5. As every polyp is stored in an individual formalin cup, an estimation of the total annual national consumption of formalin cups based would therefore be to about 330.000 formalin cups (see figure 3.6.4). Again, to make a more accurate estimation, more data would be required.



Figure 3.6.1: Population screening invitation.

### BBO Program data (2021)

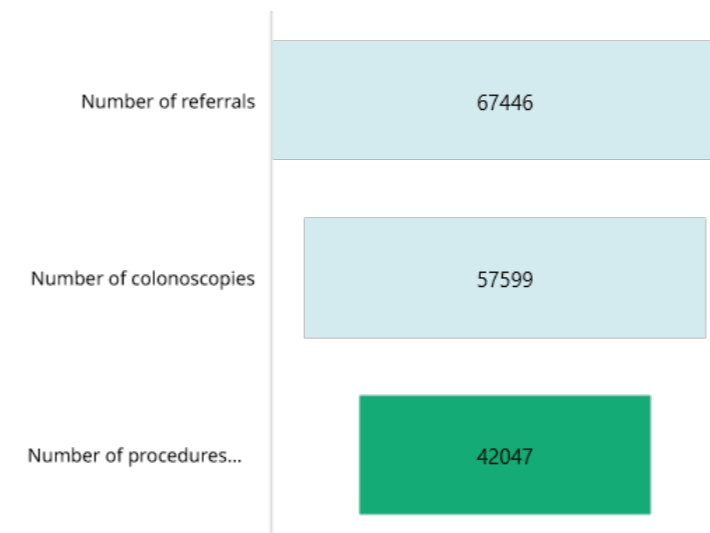

Figure 3.6.2: Number of referrals, resulting number colonoscopies and resulting number of procedures where polyps or tumours are found within the BVO program.

### Distribution of endoscopic procedures

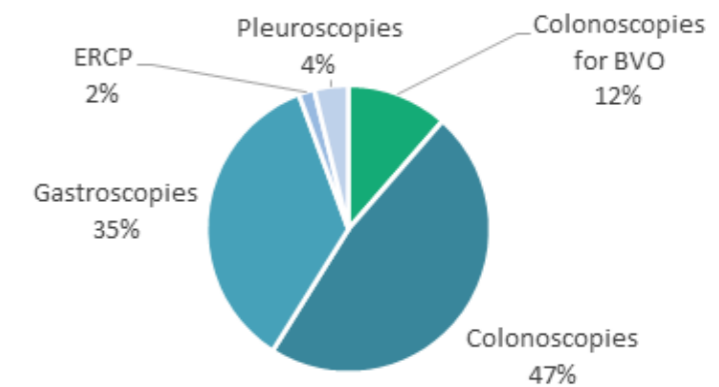

Figure 3.6.3: Distribution of varying kinds of endoscopic procedures.

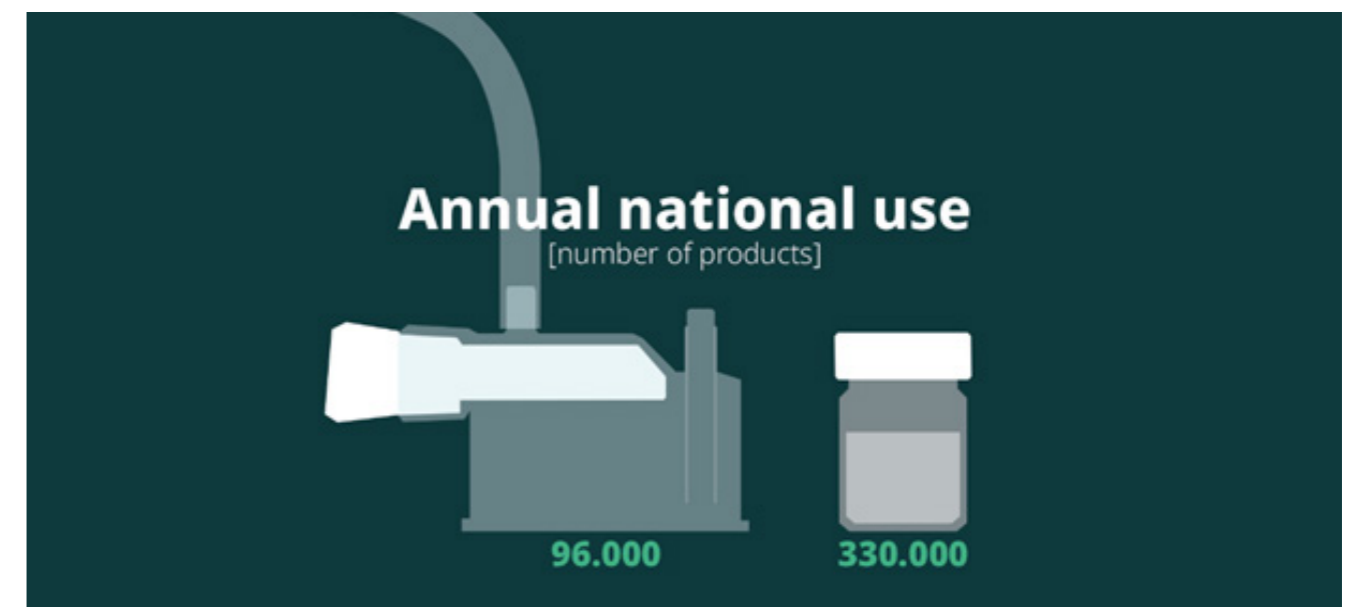

Figure 3.6.4: Estimation of annual national use of polyp traps and formalin cups

### 3.7 Conclusion

In this first part of the report, part of the first research question is explored through the sub questions that are answered below: How could a design intervention in the process of the polypectomy lead to a reduction in environmental impact?

a. What does the process of a polypectomy, and the use of a polyp trap look like?

Polypectomy takes place during endoscopy, a non-invasive surgery where a surgeon uses an endoscope equipped with a camera to inspect a patient's intestines. The process of a polypectomy, is the surgical removal of a polyp, using an endoscopic instrument such as a snare. The Endoscope system uses suction created by the pump system

to transport the removed polyp through the biopsy channel of the endoscope. Polyp lands in the drawer of the polyp trap. The nurse checks whether the polyp has completely entered the polyp trap through the window, and replaces the filled drawer with an empty drawer. The nurse then places the polyp in a formalin cup, that is transported to and analysed in the lab after the procedure. As there is a great variation in number of polyps found for different patients, the whole polypectomy process is very efficient and generally happens within a couple of minutes. The process of using the polyp trap can even be under a minute, and the airflow through the endoscope is only interrupted for mere seconds, to not disturb the physician workflow.

b. Where in this process could a design intervention lead to a reduction of the environmental impact?

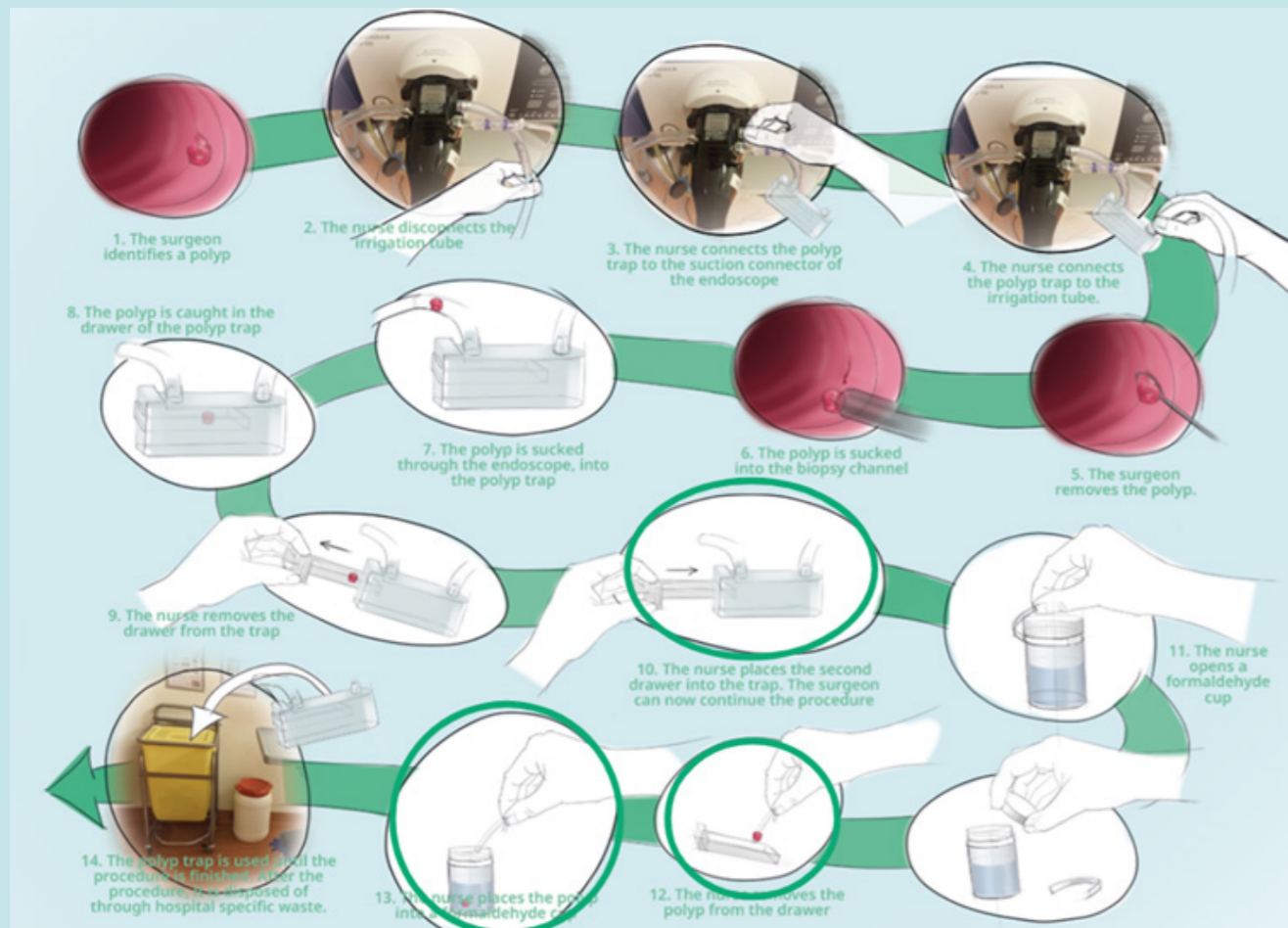

Figure 3.7.1: Possibilities of design interventions that reduce the environmental impact within the polypectomy procedure.

There are different practices in a polypectomy that could be altered to reduce the environmental footprint (see figure 3.7.1). First, at times only one drawer is used, if there is only one polyp to be removed. In this case, the second drawer is disposed of unused. Therefore, a structure to reuse leftover drawers, or providing polyp traps with one drawer and providing additional individual drawers, might somewhat decrease waste generation. Secondly, some polyp traps come with retrieval stickers; small plastic tools used to remove the polyp trap from the drawer. However, there are also different ways to remove the polyp without this product. The polyp can be removed by dipping the drawer into the formalin cup, a leftover piece of plastic from the sealing part of the cup itself is sometimes used, and some nurses remove the tissue with their fingers. However, this process might be less hygienic. Lastly, polyps are transported in individual formalin cups. A redesign of these cups, or a reprocessing or recycling structure might lead to decreased waste production and a lower environmental footprint.

There are also opportunities within the

product journey of the polyp trap (see figure 3.7.2). Perhaps the whole product can be reprocessed, or less critical parts of the product could be used per day without reprocessing, while more critical parts are used per patient. Additionally, the product could possibly be disposed of through the general waste stream, or even be recycled if it would be disinfected before disposal.

c. What are the requirements that are relevant to the polyp trap?

Based on the observational and literature research, various requirements were determined concerning the usability, material properties and sustainability of the polyp trap. These requirements are listed and explained in chapter 4.3: List of requirements and wishes.

d. Which healthcare professionals are stakeholders in the process of endoscopy and polypectomy?

The nurse is the main user of the polyp trap and operates it from start to end. As they quickly need to shift between removing and

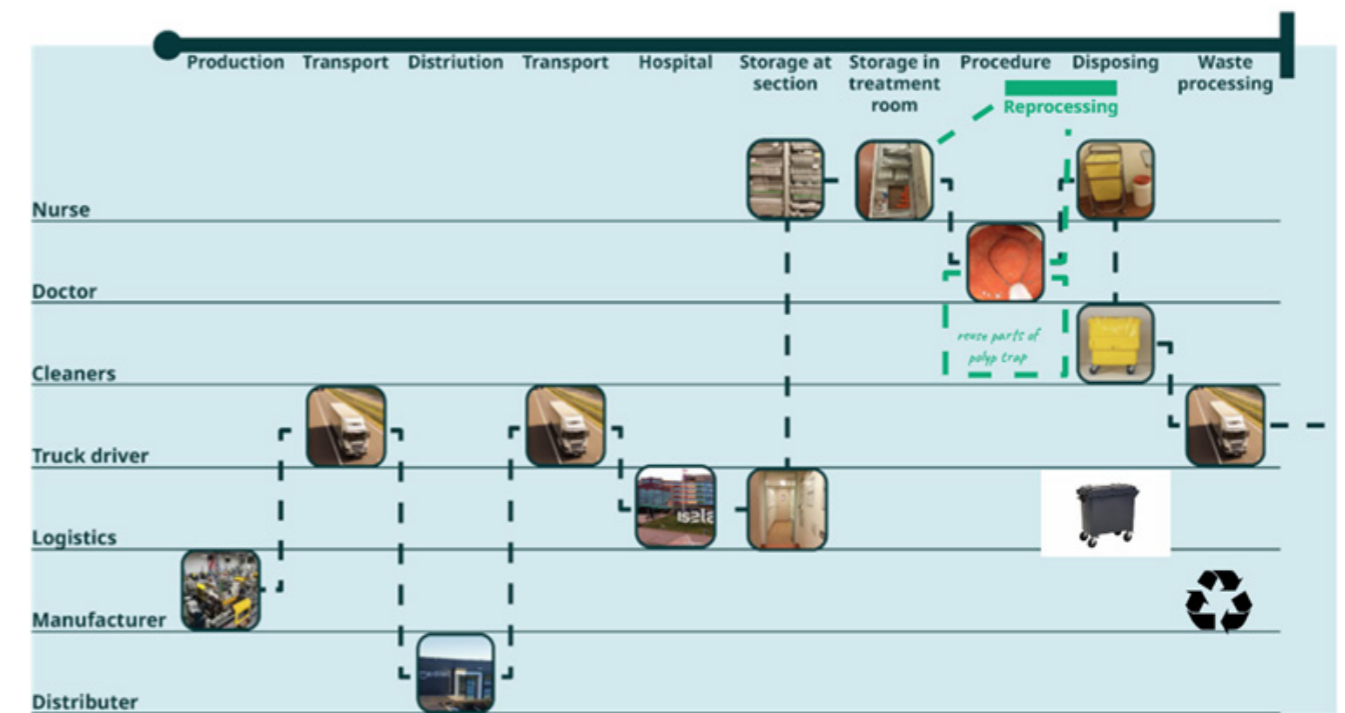

Figure 3.7.2: Possibilities of design interventions that reduce the environmental impact within the polyp traps lifecycle.



storing the polyp and assisting the surgeon, their main requirement for the polyp trap is that it is easy and fast in use. Although the surgeon does not directly interact with the polyp trap, they also rely on fast operation to be able to resume the operation after the removal of a polyp. Therefore, these two stakeholders will have to accept a redesign of the polyp trap for it to replace the current model. Therefore, this redesign should be at least as fast and practical in use as the current model in order to be accepted by nurses and doctor.

However, without a redesign, interventions can already be implemented to lower endoscopies' environmental footprint. An endoscopy suite could be stocked with varying sizes of formalin cups to enable nurses to use a fitting size cup relative to the polyp. Surgeons could make sure not to use more complex SUD such as hot snares when this is not strictly necessary. Infection prevention personnel could check protocols to prevent wasteful routines, such as exchanging gloves more than necessary, disposing of unused equipment, or equipping the nurse responsible for monitoring the patient's vital signs with an apron. Additionally, they could consider more circular options for products that are typically SUD, such as clothing.

Some hospitals already have green teams within departments (Committees where various employees identify opportunities and implement sustainable interventions). Green teams in hospitals could bring these different stakeholders together to generate and evaluate ideas for sustainable interventions. They could help to detect wasteful practices and collect data about SUD use. However, they also rely heavily on internally motivated personnel, who often already have many other responsibilities. Collaboration between different departments, or even between hospitals and with the scientific community by sharing data, and interventions that do (not) work might not only take some of the workload of green team employees, but could also accelerate the implementation of more circular and sustainable practices and help close the knowledge gap surrounding the environmental impact of the healthcare

system through a bottom-up approach.

**e. What other devices and SUD are used during a polypectomy, and how do they interact with the polyp trap?**

The most important instrument used during an endoscopy is the endoscope. Through the instrument channel, instruments such as snares and biopsy forceps can be inserted into the patient's intestines, and polyps or tumours can be removed surgically.

The endoscope is connected to the endoscope processor, which connects to the monitors and pump system. This pump system provides suction to the endoscope that is used to remove bodily fluids and debris, and transport polyps and polyp tissue to the polyp trap.

The irrigation system is connected to the outlet of the polyp trap with a tube. The system transports bodily fluids and flushing water to the wastewater bag. The wastewater bag is disposed of entirely through hospital specific waste when it is full.

Polyps are transported from the polyp trap, to a formaldehyde cup. The formalin preserves the polyp during storage and transportation to the lab. In the lab, the polyp is taken out of the cup for analysis, and the cup is disposed of.

**f. Could a design intervention in the (interaction between) SUD used during polypectomy lead to a reduction in environmental impact?**

The endoscope, and some of its accessories are reprocessed. They are transported to the sterilisation department in the same tray that is used to transport the endoscope to the operation room. If a redesign of the polyp trap were to be reprocessed, this existing structure could be used to transport the device to and from the procedure room, and some of the reprocessing steps could possibly be combined.

The irrigation system and the polyp trap share a function: Transporting fluids. Therefore,

there might be an opportunity to combine these two SUD into an integrated system, decreasing the amount of materials and components used. However, this would also lead to different challenges. The wastewater bag is used for several patients, whereas the polyp trap is used for a single patient. Therefore, hygienic risk could occur. Another opportunity could be adapting the system to connect to a sewer, as the practice of disposing water through incineration seems somewhat cumbersome.

The function of the polyp traps drawer is also quite similar to that of the formalin cup; containing a polyp. Therefore, there might be an opportunity in combining the two devices. Perhaps the drawer could function as a lid for the formalin cups. This does lead to different challenges. About 3.5 formalin cups are used per polyp trap. Therefore, combining the two might lead to more material use rather than less. Additionally, it might put nurses in direct contact with the formalin solution, which can be harmful. Another possibility could be adapting the formalin cup to be able to store more polyps. However, this could also lead to a risk of tissue contamination.

*In the second part of this report, the current product will be explored through a detailed analysis of three commonly used models of the polyp trap in the Netherlands. Its shape, function and material use will be defined, resulting in the answer to research question 1a: What are the requirements that are relevant to the polyp trap? Furthermore, the lifecycle of the polyp trap will be analysed, and a cradle-to-grave lifecycle analysis screening will be performed. The results of this fast-track LCA will result in the answer to research question 2a: How can the environmental impact of the polyp trap be defined? What type of environmental harm does the polyp trap cause? And 2b: What is the current environmental impact of the polyp trap/polypectomy on a yearly base in the Netherlands? This will lead to the answer to research question 2: What is the current environmental impact of the polyp trap?*

# Part II The Polyp Trap

# 4. Polyp Trap

## 4.1 Evolution of the polyp trap

Although the polyp trap is a much more simple product compared to the endoscope it is connected to, a similar increase in complexity has occurred in its development. This evolution is visualised in figure 4.1.1 Before the invention of the polyp trap, the irrigation tube of the endoscope would be disconnected, and a patch of gauze was used to catch the polyp (P1; P7 see appendix D). This approach had some major disadvantages, concerning infection risk and efficiency. The disconnected tube caused risk of splashing for the nurse catching the polyp, and a drop in negative air pressure for the physician, who had to wait until the tube was re-connected to continue to work (P1; P7 see appendix D).

This led to the development of the in-line model of the polyp trap. This model significantly decreases the splash hazard for

the nurse, as water exiting the irrigation tube could be drained before removing the polyp by unscrewing the bottom of the polyp trap. However, this action sometimes still releases some fluids and interrupts the workflow of the physician (Meditec, 2023).

Another variation is the chamber model, which enables the nurse to catch four polyps, without needing to disconnect the polyp trap. However, if debris enters this trap, it is difficult and time consuming to remove it (P6, see appendix D).

This is why most hospitals in the Netherlands, now use the tray or drawer model (Meditec, 2023). This polyp trap, always provided with two drawers catches the polyp in a sieve-like one drawer, that can immediately be replaced by a second drawer (P1; P6, see appendix D) There are different variations of this model

(Meditec, 2023), with number of components ranging from four to ten, using 3-5 different materials, excluding packaging.

The newest innovation in polyp traps, could be the addition of light. As the light in endoscopy rooms is often dimmed to optimize the brightness of the monitors (P1, see appendix A), polyps can be difficult to spot in the polyp trap, especially if they have been fragmented. Some manufacturers now try to overcome this issue, by adding a glowstick or even an LED to the polyp trap. However, these models are not used in the Netherlands, and it is unclear how commonly these products are used globally. When asked what they think of this feature, two nurses independently answered that they usually hold the container beneath a lamp that is already in the room. They were both content with this approach, especially it is not an issue that occurs frequently enough to

significantly interrupt their workflow, or that of the physician (P1; P2, see appendix D). To conclude, even the polyp trap, a product that undoubtedly contributed to higher hygiene standards and more efficient workflow, but is also so unambiguous that for a long time its function could be fulfilled with a simple piece of gauze, has evolved into a semi-complex product. This illustrates, that not only critical and valuable products such as endoscopes are becoming more and more complex, less critical and/or valuable products are also susceptible to this development.

## Evolution of the polyp trap

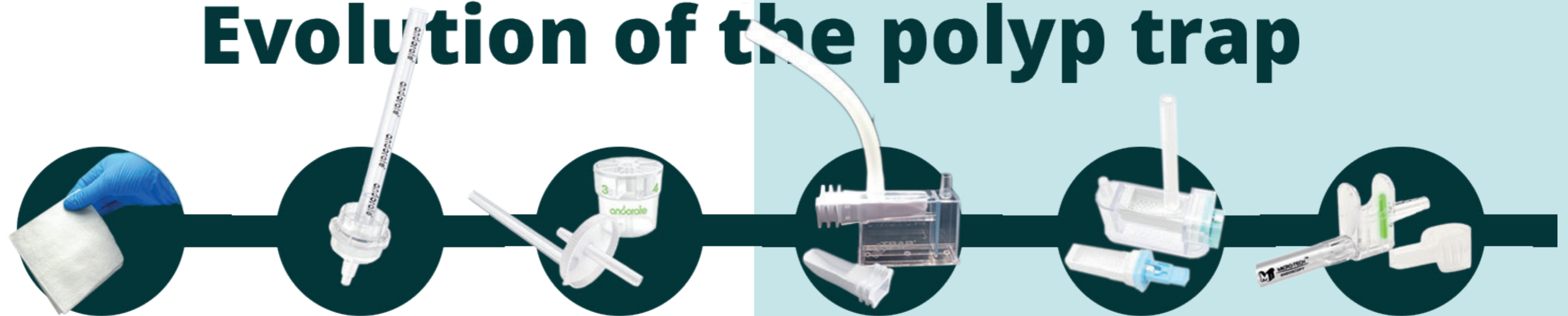

Figure 4.1.1 evolution of the polyp trap

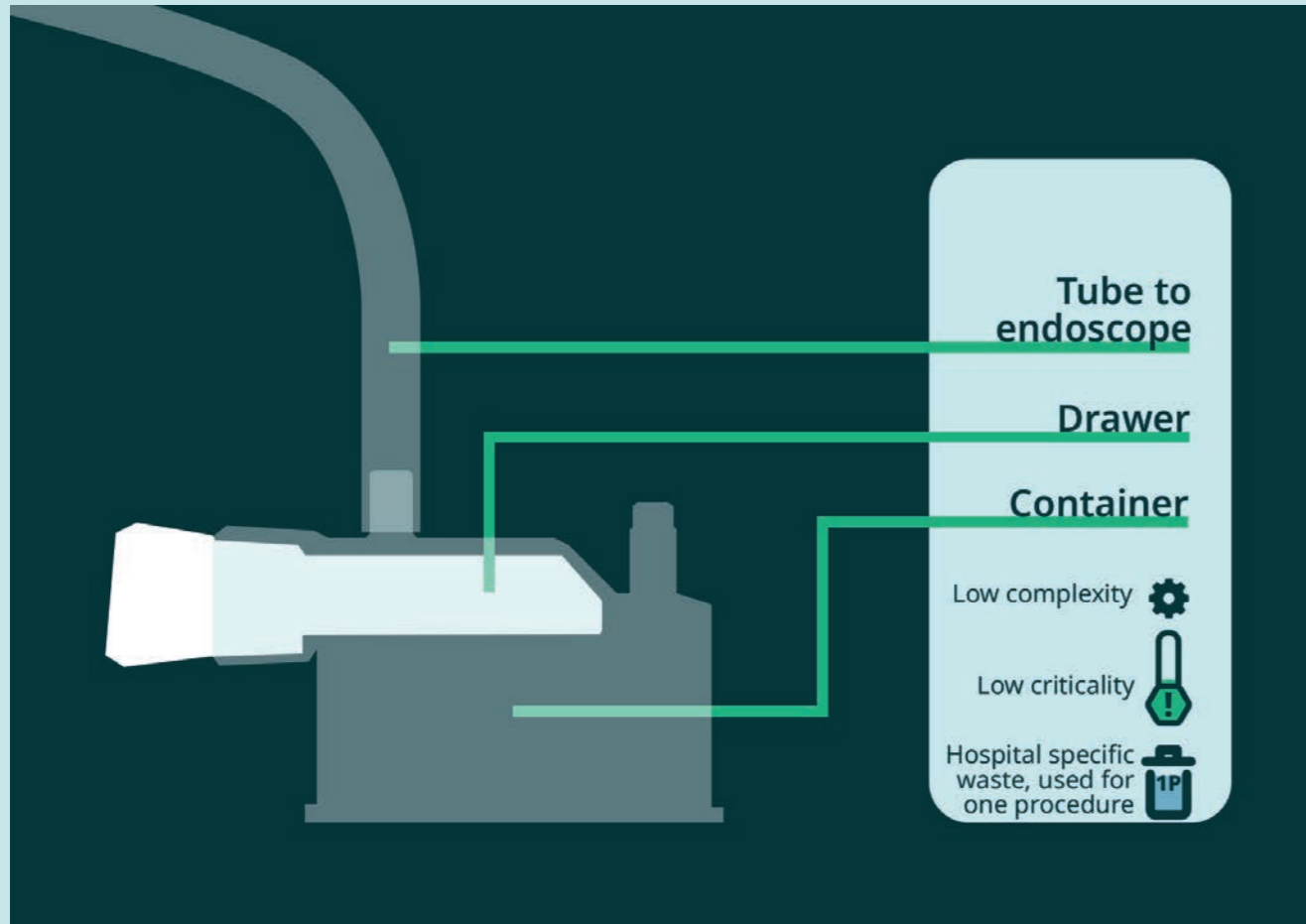

Figure 4.2.1: The polyp trap.

## 4.2 Models & Components

The polyp trap is a non-critical device. It contains four parts; The trap itself, or the container; two identical drawers, or chambers and a tube that connects it to the endoscope's biopsy channel.

The product is retrieved from a drawer whenever a small to medium sized polyp is found. After the procedure, the polyp trap is disposed of through hospital specific waste. Some hospitals in the Netherlands still use a single chamber model polyp trap (see figure 4.2.2) (Meditec, 2023). Due to the disadvantages described earlier in chapter 4.1: Evolution of the polyp trap, most hospitals are using the more efficient and hygienic drawer model. Therefore, I will focus on this model during my research.

The tube on the polyp trap is connected to the biopsy channel of the endoscope, and the irrigation tube is connected to the outlet of the container (see figure 4.2.1). Polyp



Figure 4.2.2: The Andorate PearlCatch single chamber polyp trap.

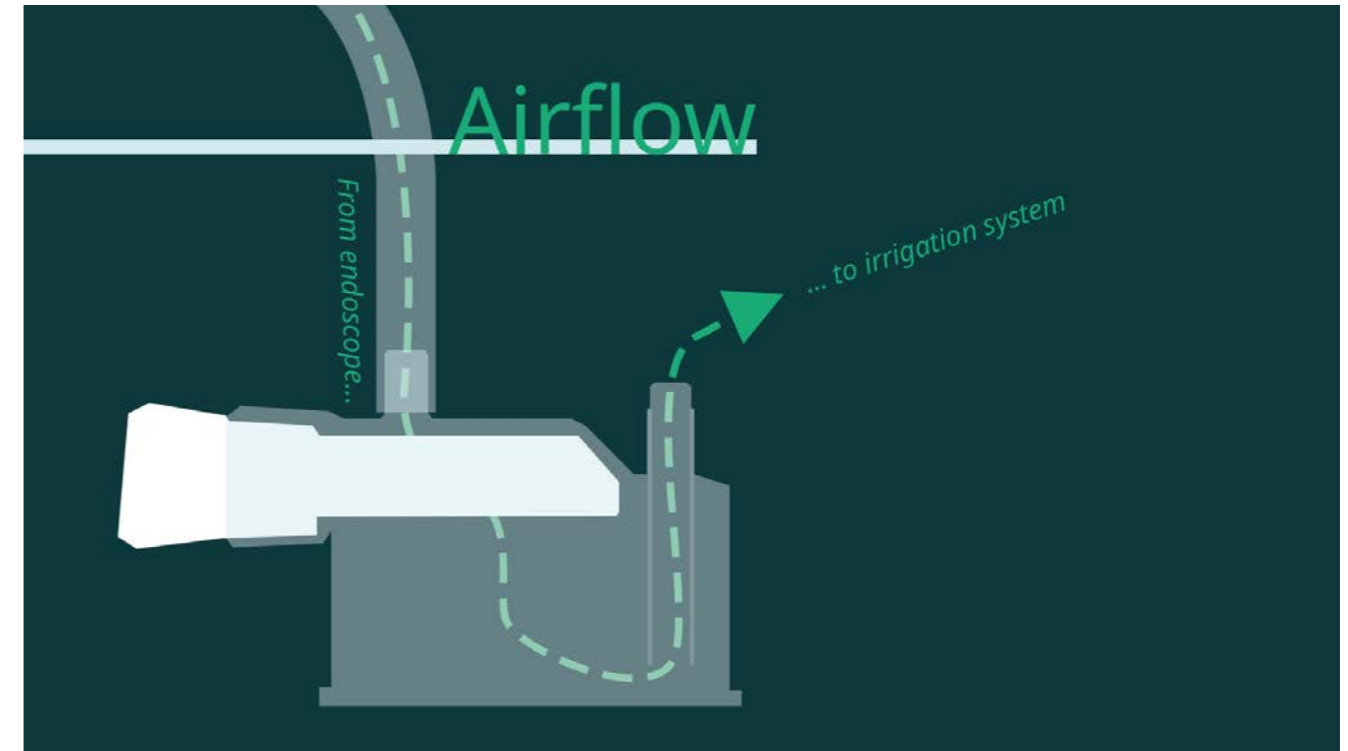

Figure 4.2.3: Airflow through the polyp trap.

tissue, air and water flows from the tube through the polyp trap to the irrigation system (see figure 4.2.3).

Three models that are commonly used in the Netherlands, are the Steris E-trap (see figure 4.2.4), Endo-Safier polyp trap with two drawers (see figure 4.2.5) and the Andorate ThomasTrap polyp trap with two removable chambers (see figure 4.2.6). Meditec distributes the latter two models. All three models are quite similar in size, shape and functionality. The main difference between the three models, is the connection

between the drawer and the container. Another difference could be the materials used. Although some packaging material is marked, most materials were not identified. Through Meditec, the materials of the Endo-Safier were specified. Manufacturers for the Steris eTrap and the Thomastrap were contacted, without success. Therefore, the assumption was made that the Steris E-Trap and the ThomasTrap are made from comparable materials. As each model has to adhere to the same requirements, and is probably made as inexpensive as possible, this could be plausible.

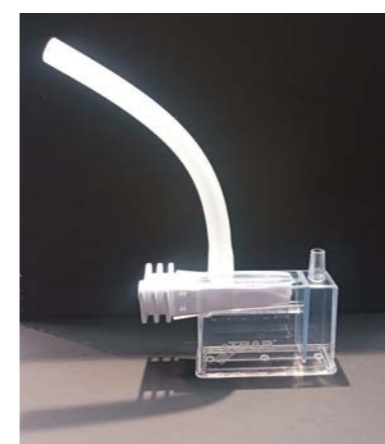

Figure 4.2.4: The Steris E-trap polyp trap.



Figure 4.2.5: The Endo-Safier polyp trap with two drawers



Figure 4.2.6: The Andorate ThomasTrap polyp trap with two removable chambers.



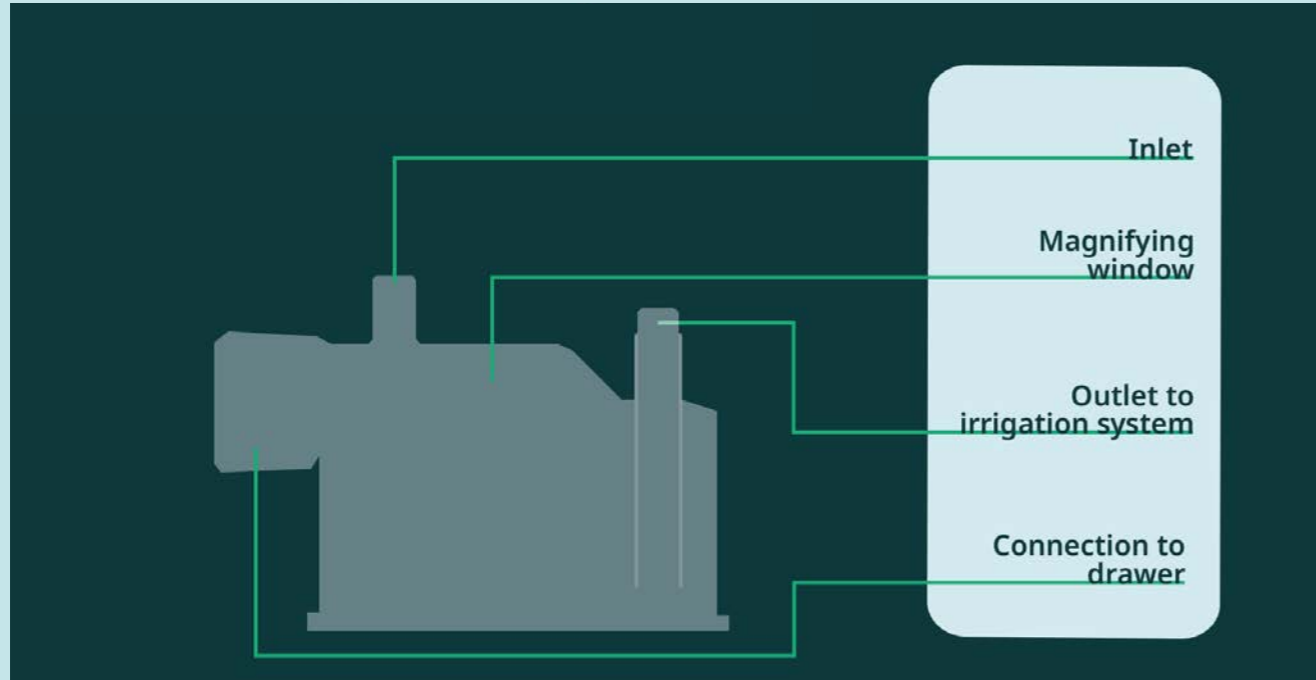

Figure 4.2.7: Container of the polyp trap.

### Container

The container is the main part of the polyp trap see figure (4.2.7). During the procedure the nurse checks whether the polyp tissue has entered the trap through the top of the polyp trap. Therefore, this part needs to be transparent. Some models, such as the Steris-E-Trap and the Endo-Safier have a small magnifying window (see figure 4.2.10 & 4.2.11), to make polyp tissue even easier to spot. As a pump connected to the irrigation

system creates a vacuum, the container needs to be stiff enough as not to deform due to the air pressure (P1; P5, see appendix A). The container is made from three parts that are most likely welded together; the top part, the bottom part and the entrance part for the drawer (personal communication H&P moulding, 2023) (see figure 4.2.9).

The current container is made out of a stiff, clear plastic Acrylonitrile Styrene (also referred to as AS, ASA or SAN) (Personal

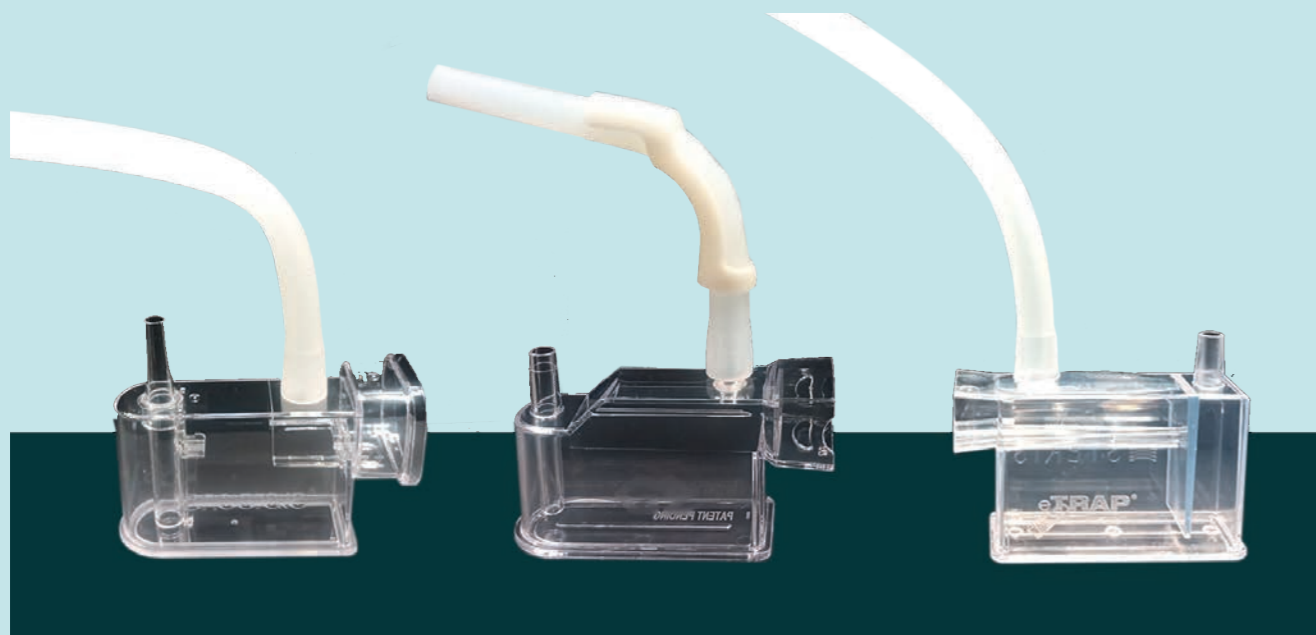

Figure 4.2.8: Various polyp trap containers

communication Meditec, 2023). AS is a rigid material with high optical qualities.

### Tube

A tube is connected to the inlet side of the polyp trap. When the polyp trap is connected to the endoscope, this tube replaces the irrigation tube, which is moved to the outlet of the polyp trap. The polyp trap's tube is bent, as a straight tube could cause the polyp trap to hang sideways, which can hinder the airflow (P2, see appendix D) (Personal communication Meditec, 2023). There are different ways to get a bended tube. The tube of the Steris E-trap and the ThomasTrap are pressed into a bended shape in their packaging. When taking the product out of the packaging, the bent becomes a bit less pronounced, but is still present. The Endo-Safier uses a different approach. It has an 'elbow' part, that bents the tube into shape (see figure 4.2.7). This elbow part is made from Polyethylene (PE). The tube itself is made from silicone rubber (Personal communication Meditec, 2023)

### Drawers

The Polyp trap comes with two drawers. The drawers are alternated whenever one drawer catches a polyp. This results in a minimal drop in suction for the surgeon, a hygienic workspace, as there is minimal

splashing, and a low risk of losing polyp tissue (see figure 4.2.12).

The polyp trap has a handle which the nurse uses to pull the drawer out of the trap, and push it back in. It is important that this seal is airtight. If air escapes through this connection, a polyp entering the drawer could be sucked towards the leak, and stick to the top of the container rather than the sieve part of the drawer. This hinders the workflow for the nurse



Figure 4.2.9: The top, bottom and entrance part of the container of the polyp trap.



Figure 4.2.10: Magnifying window on the Steris E-Trap



Figure 4.2.11: Magnifying window on the Endo-Safier

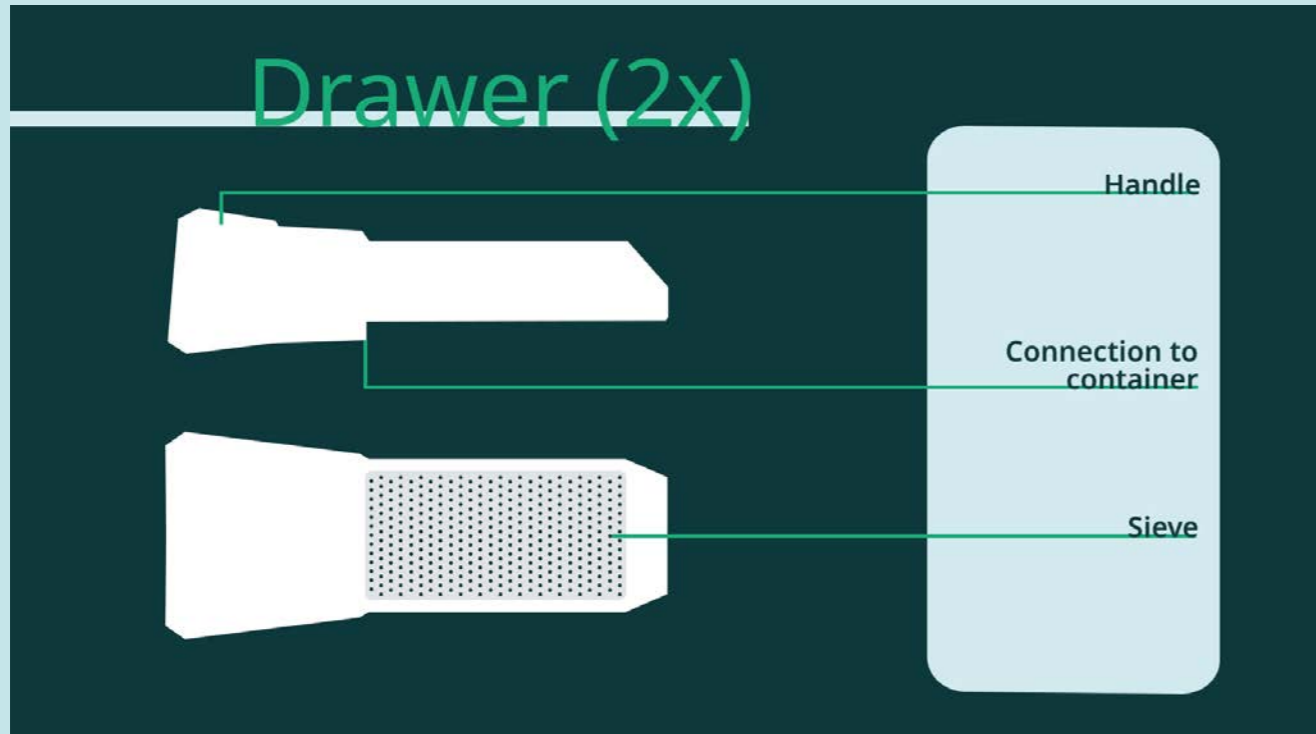

Figure 4.2.12: Polyp trap drawer.

and the surgeon, as it takes more time to get the polyp out of the container, and the drawer cannot be replaced immediately (P1 & P2, see appendix D).

The different models each use a different method of connecting the drawer to the container all products use a thermoplastic elastomer as a sealing part. As the type of elastomer was not specified by the manufacturer, an educated guess was made based on literature research and a sink-flow test (see appendix E), and the material was determined to likely be polyurethane (PU).

The Steris drawer is a singular part, made entirely from a PU. It creates an airtight seal with the container through friction fit.

The Endo-Safier and ThomasTrap use the same material for the sealing part. However, for the Endo-safier, the handle is made from polycarbonate (PC) and the 'sieve part' is made from Polyethylene (PE). The drawer handle of the drawer is connected to the sieve by snap fits. The

sealing part is pressed in between. The drawer connects to the container with another snap fit connection. The snap fit can be opened by pressing the sides on the handle, causing the click fingers to retreat inwards.

The drawer of the Thomas Trap is compiled of three components made from Polyethylene (PE) It is the most complex variation of this component. It includes a spring is used that creates a hinge mechanism. The handle of the hinge should be pushed down or up in a straight angle relative to the tray to press the lid with the sealing part inward (see figure 4.2.14). To remove the drawer, the nurse pulls the handle. The lid and the tray are connected with snap-fits, the spring and the sealing part sit in between. The handle slides into a groove in the lid and is pushed up by the spring.

Although the handle of the drawer is sometimes coloured, the sieve part is always white. Polyps can sometimes be



Figure 4.2.13 Polyp trap drawer of the Endo-Safier, ThomasTrap and Steris e-Trap.

difficult to spot, because of their small size and thin tissue. Additionally, polyps can sometimes be fragmented due to the suction power. Therefore, a light coloured sieve part can help the nurse to spot polyp tissue.

The Endo-Safier and the ThomasTrap both come with retrieval stickers. The retrieval sticker (see figure 4.16) is used to collect the polyp tissue from the drawer.

Not every nurse uses the retrieval sticker. Other approaches are dipping the drawer into the formalin cup, or using a leftover strip of plastic from the lid of the formalin cup. Sometimes the tissue is removed by hand. As this approach is less hygienic, it is not according to protocol.

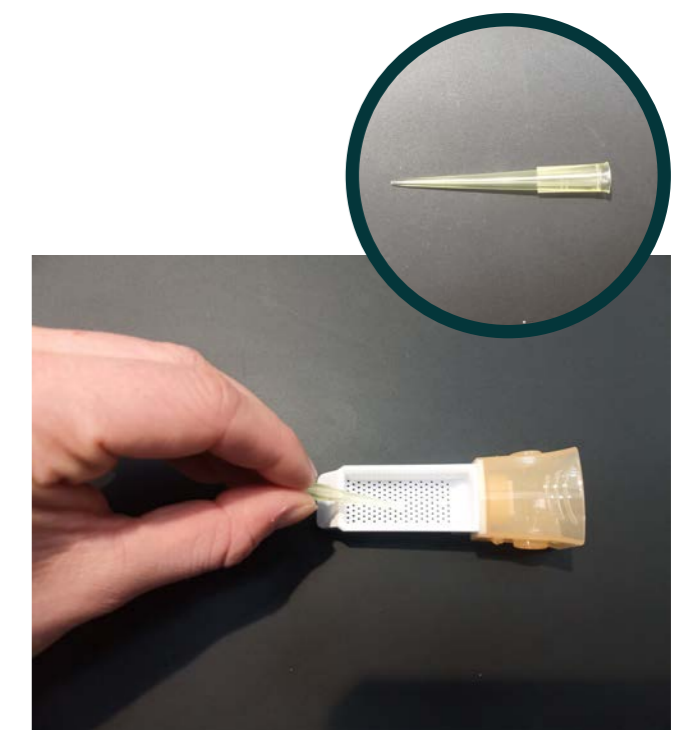

Figure 4.2.14: Closing mechanism of the ThomasTrap

Figure 4.2.15: Retrieval sticker.



## Packaging

Non-critical products do not need to be sterile according to EU regulations. As the polyp trap is a non-critical product, manufacturers are free to design their own suitable packaging. As the packaging does not come into contact with the patient, it is disposed of through the general waste stream.

The Steris E-trap is the only trap that comes in blister packaging made from PET (see figure 4.2.16), rather than a bag made of LDPE. Apart from a label, it does not come with any accessories. Nurses in the Isala ziekenhuis (P1, see appendix D) noted that the size of the packaging was quite large compared to the previous model they had used which was packaged in a bag. They

preferred the smaller size, as it took in less space in the drawer. Additionally, the tray uses more empty space compared to a bag during transport and disposal.

The Endo-Safier is packaged in a single LDPE bag (see figure 4.2.17). The bag has a perforated edge, to enable easy opening. It comes with a label and a retrieval sticker, packaged in an individual bag, with a paper back and LDPE front.

The ThomasTrap polyp trap comes in a bag with a paper back, the front is LDPE. It comes with a small label, a retrieval sticker and an elbow-shaped tube holder, that forces the tube to make a bend. This part is made out of PET (see figure 4.2.18).



Figure 4.2.17: Endo-Safier packaging.



Figure 4.2.16: Steris e-Trap packaging



Figure 4.2.18: Andorate Thomastrap packaging.

## 4.3 List of requirements and wishes

Through the analysis of the Polyp trap, its use and its context, I determined the following requirements that will be used to evaluate the concepts. Therefore, this chapter answers research question 1.c: What are the requirements that are relevant to the polyp

### Requirements

#### Sustainability

- The redesign of the polyp trap should lead to a reduction in its CO2 footprint.
- The redesign of the polyp trap should lead to a reduction in waste.

#### Use

- The nurse should be able to remove a polyp in less than ten seconds
- The interruption in air and waterflow during removal of the polyp from the polyp trap, should take no more than five seconds.
- The airflow through the product should lead the polyp to the intended collection spot.
- The polyp has to be visible to the nurse, while it is inside the polyp trap.
- The nurse should be able to remove the polyp from the trap in two movements, using one hand.
- The polyp trap should be able to contain at least 16 mL of water (see tests)
- The polyp trap should be able to catch up to 10 mL of debris without becoming

blocked.

- If the polyp trap is filled with wastewater, it should be able to empty itself within one second.

#### Hygienics

- When removing the irrigation tube from the polyp trap, no water should leak out of product
  - When removing the drawer from the polyp trap, the water contained in the trap should not leak out.
- #### Material
- Air and water should only be able to enter and leave the polyp trap through the intended in and outlets.
  - The air and waterflow through the product should not be hindered by the device.
  - The polyp trap should not deform due to the air or waterflow through the device.

#### Packaging

- The product should be packaged in a bag rather than a box or container, as this is more space efficient.

- The packaging should clearly and visually communicate its contents to the user.

#### **Wishes**

- The CO2 footprint reduction of the redesign should be maximised.
- The waste generation reduction of the redesign should be minimised
- The redesign contributes to a more circular healthcare system.
- The visibility of the polyp inside the polyp trap should be optimised.
- The infection risk should be minimised.
- The risk of residual polyp tissue should be minimised.
- The amount of activities required to operate the polyp trap should be minimised.
- The time required to operate the polyp trap should be minimised.
- The packaging of the polyp trap should be minimised.

## 4.4 Bill Of Materials

Steris eTrap

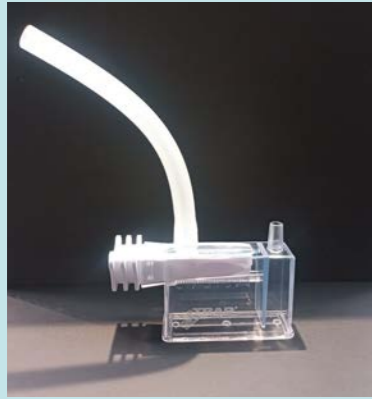

**Polip trap & accesories**

Components	Container	Drawers	Tube
<b>Number</b>	1	2	1
<b>Material</b>	Styrene acrylonitrile (AS)	Polyuthene (PU)	Silicone rubber (PDMS)
<b>Production</b>	Injection moulding; Plastic welding/ glueing	Sputgieten	Blow-moulding
<b>Weight [g]</b>	33.6	8.9	12.3

**Packaging & labels**

Tray	Label
1	1
PET	Paper
Thermoforming	
18	1

Endo-Safier



Components	Container	Handle part of drawer	Sieve part of drawer	Tube holder	Tube	Sealing part	Retrieval sticker
<b>Number</b>	1	2	2	1	1	1	1
<b>Material</b>	Styrene acrylonitrile (AS)	Polycarbonate (PC)	Polycarbonate (PC)	Polycarbonate (PC)	Silicone rubber (PDMS)	Polyuthene (PU)	Polyethylene terephthalate (PET)
<b>Production</b>	Injection moulding; Plastic welding/ glueing	Injection moulding	Injection moulding	Injection moulding	Blow-moulding	Injection moulding	Injection moulding
<b>Weight [grams]</b>	37	16	13	3.8	15	1.2	1

Bag	Front of retrieval sticker bag	Back of retrieval sticker bag	Label
1	1	1	1
LDPE	LDPE	Paper	Paper
	Laminating	Laminating	
7.8	0.28	0.01	1

Thomastrap



Components	Container	Handle part of drawer	Sieve part of drawer	Lid part of drawer	Sealing part	Spring	Tube	Retrieval sticker
<b>Number</b>	1	2	2	2	2	2	1	2
<b>Material</b>	Styrene acrylonitrile (AS)	Polycarbonate (PC)	Polycarbonate (PC)	Polycarbonate (PC)	Polyuthene (PU)	Steel	Silicone rubber (PDMS)	Polyethylene terephthalate (PET)
<b>Production</b>	Injection moulding; Plastic welding/ glueing	Injection moulding	Injection moulding	Injection moulding	Injection moulding	Excruding	Blow-moulding	Injection moulding
<b>Weight [grams]</b>	31.6	2.1	9.2	3.7	1.1	5	11.1	0.23

Front of bag	Back of bag	Tube holder	Label
1	1	1	1
LDPE	Paper	Polyethylene terephthalate (PET)	Paper
Laminating	manufacturing; laminating	Thermoforming	
1	1	5.0	0.5

Figure 4.4.1: Bill of materials



## 4.5 Fast-track LCA

*To determine the current environmental impact of the polyp trap, I will perform a cradle-to-grave fast-track LCA screening of the three different models of polyp traps, and three different sizes of formalin cups. The formalin cups are included in this fast-track LCA, as their use is closely connected to that of the polyp trap, and their impact might be significant relative to that of the polyp trap, as generally more formalin cups are used compared to polyp traps. With the fast-track LCA, research question 2: What is the current environmental impact of the polyp trap? Will be answered through research question 2.a: How can the environmental impact of the polyp trap be defined? What type of environmental harm does the polyp trap cause? And research question 2b: What is the current environmental impact of the polyp trap/polypectomy on a yearly base in the Netherlands?*

Within this analysis, the three different models described in chapter 4.2 and their individual components will be compared. The lifecycles of the polyp traps, from production to disposal, are visualised in figure 4.5.1-4.5.3.

First, the three models of polyp trap will be compared to each other. The functional unit for this case, will be per product. The waste production in mass, CO<sub>2</sub> footprint and Eco-costs of each polyp trap will be compared to the other. Additionally, CO<sub>2</sub> footprint of the individual components will be calculated. Secondly, an estimation of the annual national waste production CO<sub>2</sub> footprint of the average polyp trap and two variations in size of the formalin containers will be made. The functional unit is therefore per year.

### Input and data

As input for this fast-track LCA, I will use the Idemat 2023 database to retrieve data about the carbon footprint and eco-costs for various materials, production processes, transport and disposal. Additionally, the estimation of the annual number of endoscopies in the Netherlands made in chapter 3.6 will be used to estimate the total annual number of used polyp traps and formalin cups. This estimation will be compared to an estimation of the total annual polyp trap sales in the Netherlands, based on sales data from Meditec.

### Assumptions and shortcomings

#### Idemat database

The Idemat database is compiled of data from various papers and other databases, and therefore I cannot completely guarantee the trustworthiness of every source of information, or the fairness of comparing multiple sources of information. However, due to the short time span of this project and the fact that the project entails more than just a fast-track LCA, I have decided to use the Idemat database despite its shortcomings, rather than finding and reviewing data manually. This way, I am able to present an estimation of the environmental impact of the product, and gain insight into the main factors contributing to this impact. However, the outcomes of this fast-track LCA should be approached as an estimation, and will mainly be used to compare the current situation to a new concept, rather than as objective values.

#### Material and manufacturing of polyp traps

To determine the environmental impact of the polyp trap, I performed a fast-track LCA screening of the three different models of polyp traps, of which I weighed every individual component after disassembling it. I based the materials used for the components on information from the manufacturers. Although some packaging material was marked, most materials were not identified. Through Meditec, the materials of the Endo-Safier were specified. Manufacturers for the Steris eTrap and the Thomastrap were contacted, without success. This led to the first assumption that

the Steris E-Trap and the ThomasTrap are made from comparable materials. As each model has adhere to the same requirements, and is probably made as inexpensive as possible, this could be plausible. However, best practice would be to perform an uncertainty analysis, to determine what the result of an error in this assumption would be.

Secondly, the Thomas trap contains a spring. As it is unclear what kind of steel is used to produce the spring, the average values for steel production are used. As the production technique for springs is not described in the Idemat database, I chose the deep drawing steel as a comparable alternative, as this process is most similar to the process of forming a spring.

Lastly, the container cannot be manufactured out of a single part, and is likely produced in three parts, and welded together (personal communication, H&P Moulding, 2023). As the environmental impact of welding is not described in the database, this value is neglected in the fast-track LCA.

#### Material and manufacturing formalin cups

The materials used for formalin cups are Polyethylene (PE) for the lids, and Polypropylene (PP) for the cups (Globe Scientific, n.d.) The weight of the formalin cup is an estimation, based on a simplified SolidWorks model of the product with the described size and material properties from a manufacturer (Globe Scientific, n.d.). The cups are delivered pre-filled with formalin, a solution containing formaldehyde (P7). Formaldehyde is a gas, that is used in the form of a watery solution to preserve tissue. It denatures proteins, which makes them unable to dissolve. Therefore, the sample is remains usable for a longer time, but it also becomes harder and more difficult to work with. In order to create a stable solution, methanol needs to be added to the solution. A 100% formalin solution contains 37% formaldehyde and 10-15% methanol dissolved in water. For preservation and storage of biological samples, a 10% formalin solution is used, which comes down to 4% formaldehyde and 1% methanol (Werkgroep

Arbocatalogus Gevaarlijke Stoffen, 2017). For a cup filled with 50mL formalin, this comes down to 2 mL formaldehyde and 0.5 mL methanol to 47.5 ml water. It is a biologically active substance, which should be handled carefully. Exposure to 10% formalin can cause cancer, allergic reactions when contacting skin and it is suspected of causing genetic damage (Werkgroep Arbocatalogus Gevaarlijke Stoffen, 2017). In the fast-track LCA, two variations of the formalin cup are compared: The standard 50 mL cups and the smaller 30 mL variant. could, all are pre-filled with 10% formalin. Two situations will be compared; the standard practice of using 50 mL cups, and the use of both 50 mL cups, and smaller 30 mL cups. For the use ratio of these different sizes, data from the Groene Hart Ziekenhuis (2023) will be used, where 3 small cups are used to one large cup.

#### Transport

The factory location and distribution location in the European Union are noted on the label of all product. For the distribution centres location, Meditec's facility in Lemmer has been chosen. For the hospitals location, the Isala hospital in Zwolle is used. Based on this information, an estimation of the most shipping route, means and distance can be made. Three different route calculation tools are used to make this estimation (reference). The average of these distances is calculated to make a relatively accurate estimation.

#### End of life

Another area of doubt is the energy recovery for incineration of hospital specific waste. Hospital specific waste is collected separately from general waste, as it contains hazardous and infectious waste. HSW is incinerated in its container, to prevent infection risk by preventing direct contact with the waste. Additionally, the waste stream is incinerated at a higher temperature compared to general waste incineration (Millieuservice Nederland, 2023). Although it is clear that this process is more energy intensive compared to the incineration of general waste, it is unclear how much more, and what the additional amount of CO<sub>2</sub> emissions this causes. Therefore, I will use the Idemat data of regular waste incineration as input for the



fast-track LCA. Therefore, the end of life of the polyp trap in the fast-track LCA, will have a lower environmental impact than it has in reality.

#### Estimation annual impact

The average of polyp trap sales for 30+/- different hospitals in the Netherlands is per month is about 42 (personal communication Meditec, 2023). There are 116 hospitals and 147 clinics in the Netherlands (Centrum Gezondheid en Maatschappij, 2023). This leads to an estimation of national use of 132.272 polyp traps annually. From a sample monitoring of a week at the Groene Hart Ziekenhuis, it was determined that in procedures where a polypectomy takes place, on average 3.5 polyps are removed. Assuming that the amount of polyp traps is identical to the amount of procedures where polyps are found, this leads to an annual national use 458.984 formalin cups.

The estimation in chapter 3.6 based on data from the BVO program lead to a total of 96.419 polyp traps used, about 73% of the estimation based on Meditecs sales data. As an estimation based on multiple sources of information should be more reliable compared to a single source of information, the average number of annual national number of polyp traps and formalin cups of both estimations will be used as input for this fast-track LCA, leading to a total number of 114.346 polyp traps and 396.793 formalin cups (see figure 4.5.4). The difference between these two estimations is included in the uncertainty analysis.

#### Lifecycle

The lifecycle of each polyp trap is relatively similar. Raw materials are transported to a manufacturer, and the (mostly plastic) parts are injection moulded. As the container cannot be moulded out of a single part, it is produced in three parts, and welded together, as described in chapter 4.2. After welding the container, it can be assembled. For some polyp traps, there are some steps required to assemble the drawers. For all containers, the tube needs to be connected to the inlet of the container, and one of the drawers needs to be inserted into the

polyp trap. Thereafter, the polyp trap can be packaged and transported to a distributor. From there, it will be transported to a hospital. At the hospital, it will be stored in the storage room of the endoscopy department. Some products, especially products that are bought in extremely large quantities, such as injection needles, will go past their use-by-date, after which they will be thrown away, without being used. Although polyp traps do have a use-by-date, of 5-10 years from being produced, they are generally not thrown away for this reason, as they are generally bought in smaller quantities (P1, see appendix A) Nurses will use the polyp traps from the store room to replenish the storage cabinet in the endoscopy suite. During the procedure, the polyp trap will be retrieved whenever it is required.

In figure 4.5.1, 4.5.2 and 4.5.3, the lifecycle of respectively the Steris E-trap, the Endo-Safier and the ThomasTrap are visualised.

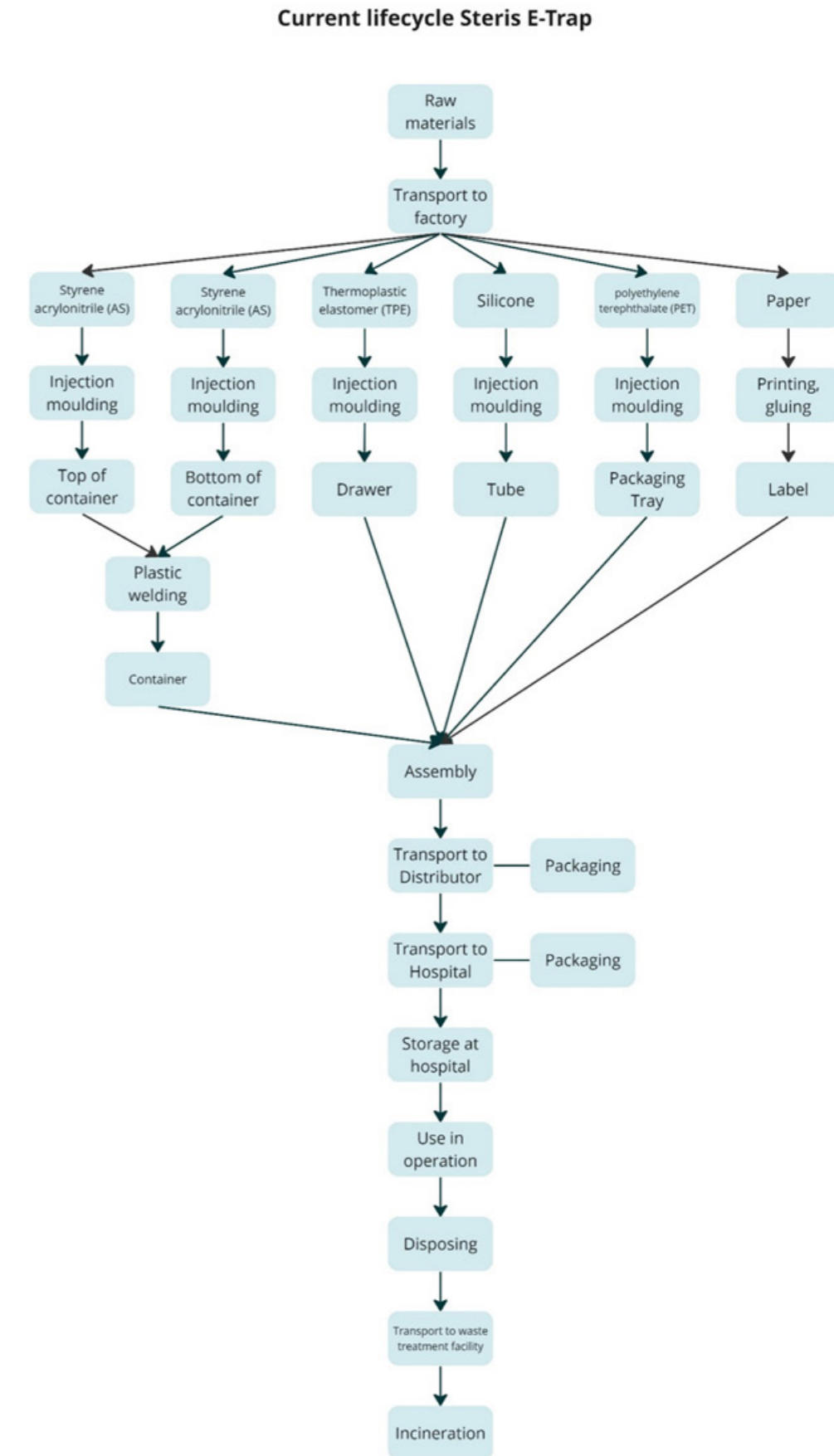

Figure 4.5.1: Lifecycle of the Steris e-Trap.

Current lifecycle Vtyl/Endo-safier

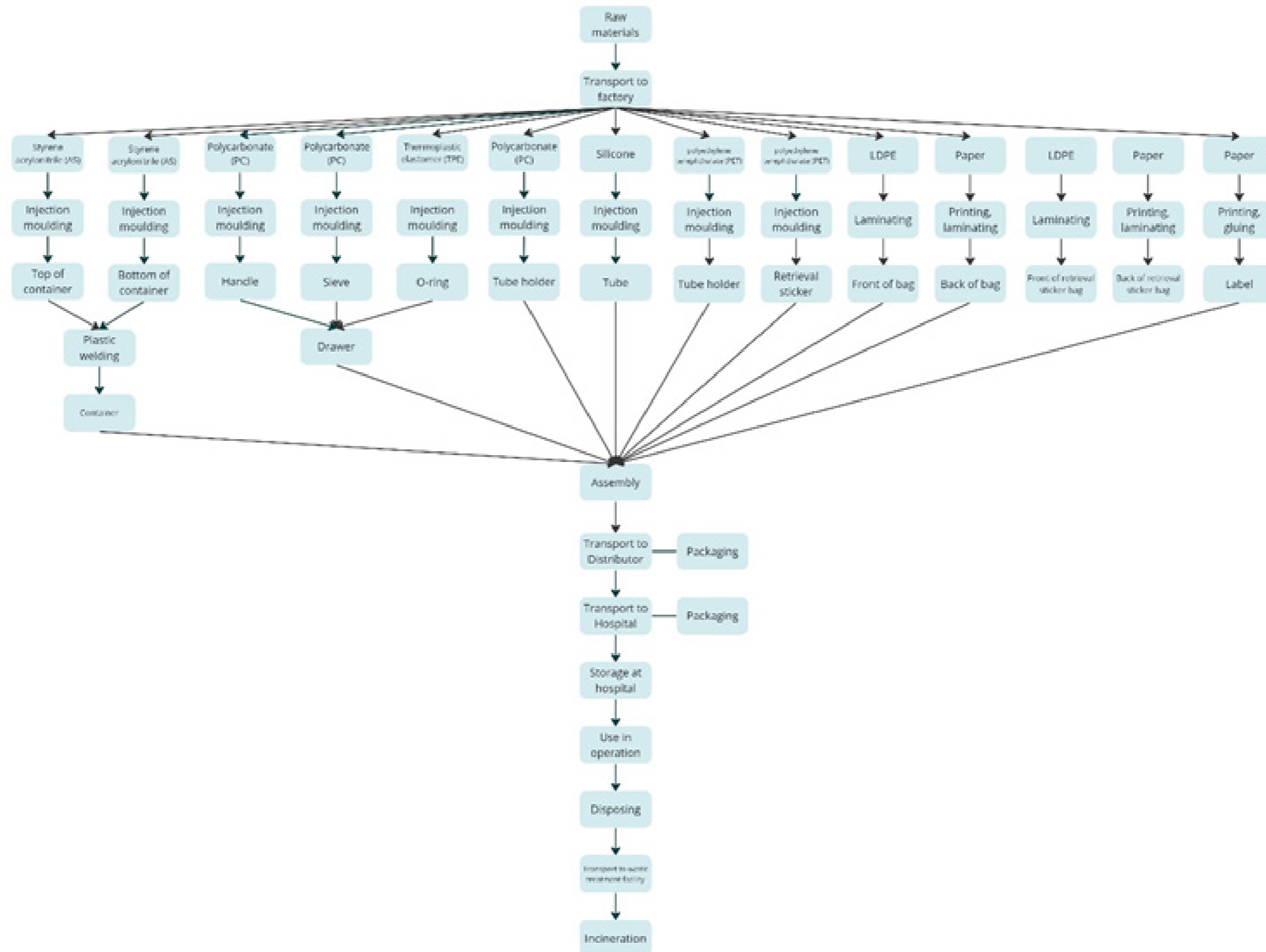
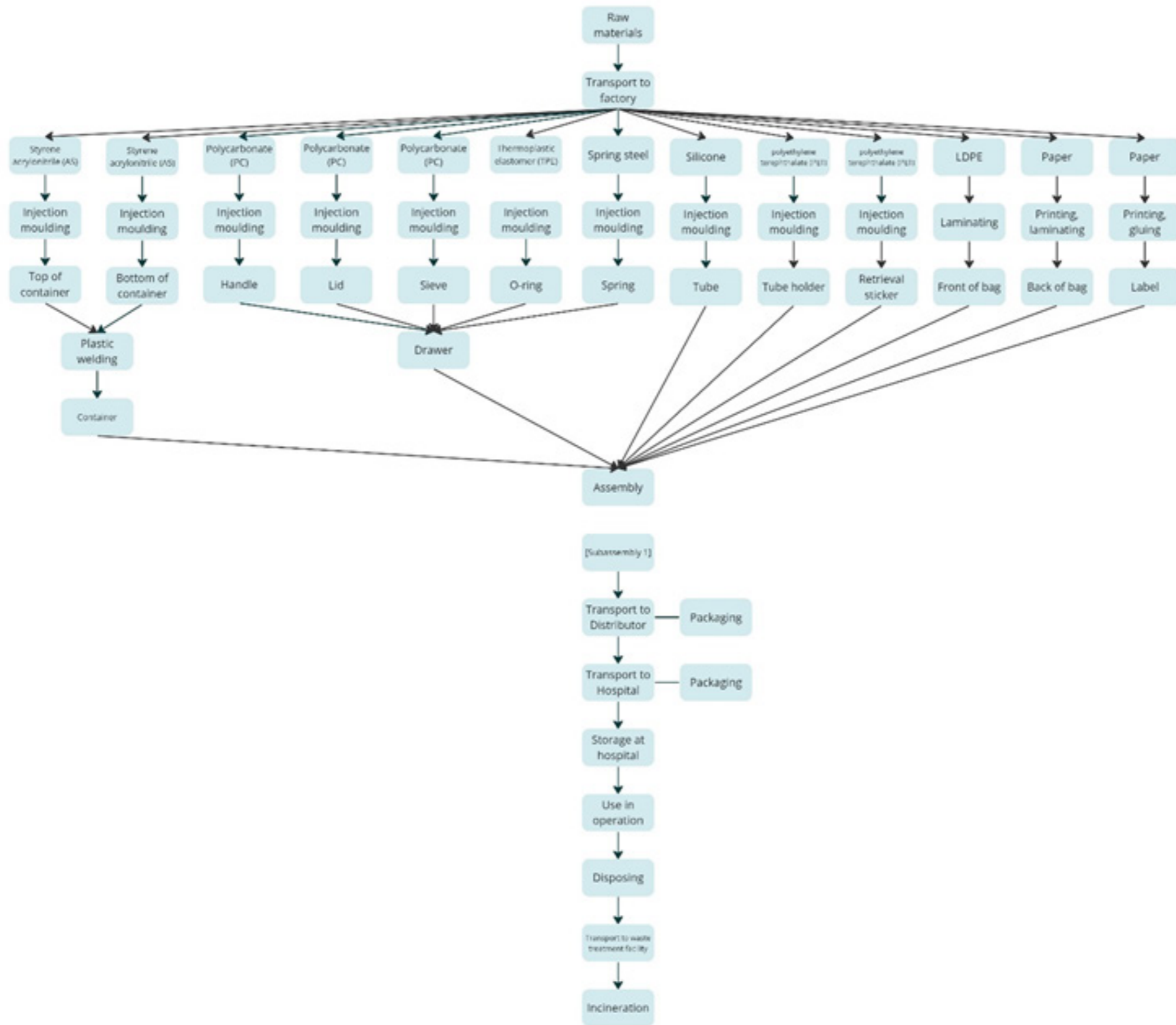

Figure 4.5.2: Lifecycle of the Endo-Safier polyp trap.



Current lifecycle Thomas Trap



4.5.3: Lifecycle of the Andorate ThomasTrap.

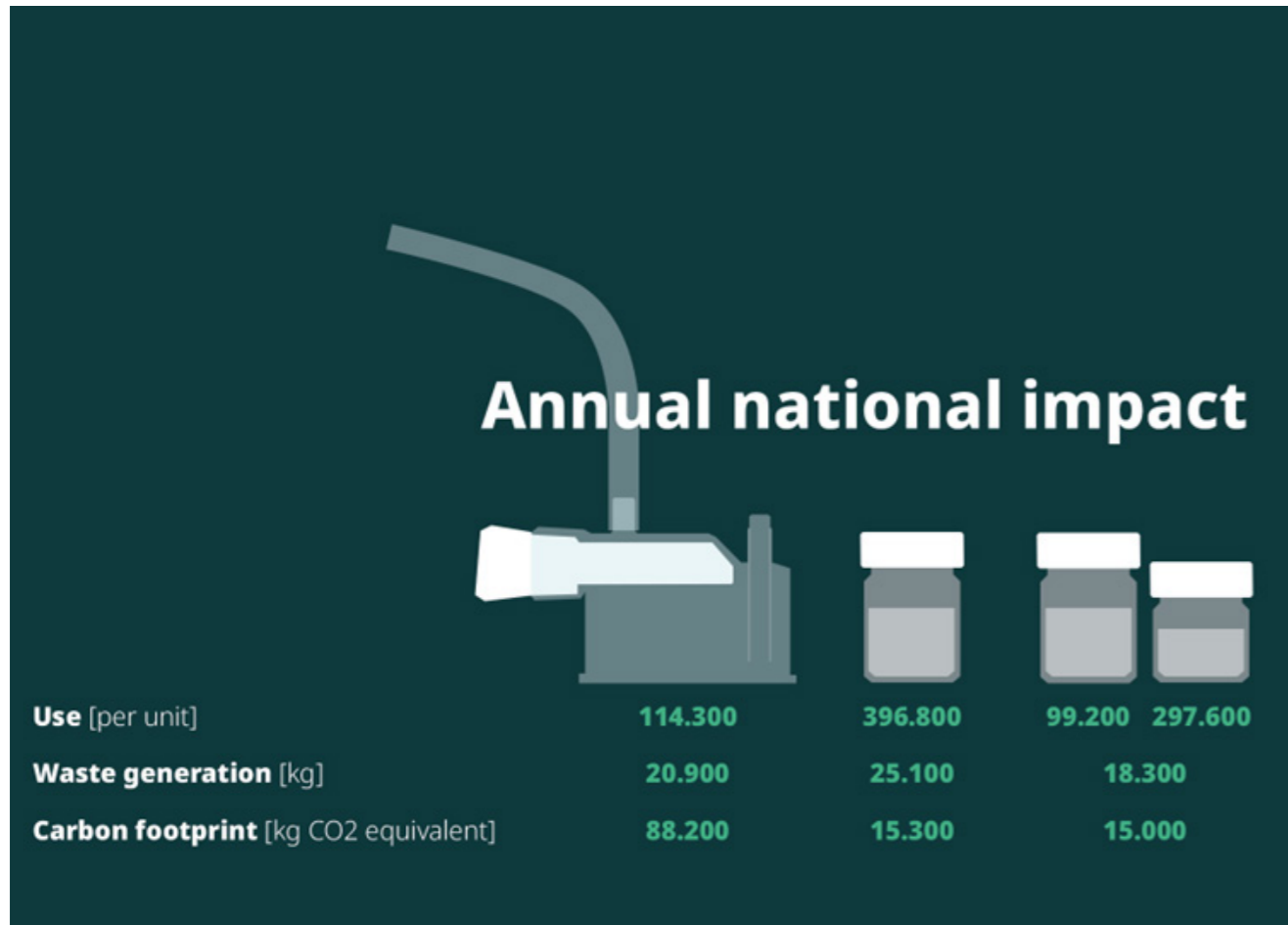

Figure 4.5.4: Summary of the estimation of annual national impact of the polyp trap and the formalin cup.

### Environmental impact of the polyp trap compared to formalin cups

Figure 4.5.4 shows a summary of the estimation of use, waste generation and CF caused by the use of polyp traps and formalin cups. Although the use of formalin cups greatly outweighs that of polyp traps (see figure 4.5.5), the carbon footprint of the polyp trap is significantly higher. Figure 4.5.6 shows an explanation for this difference in impact, as the difference in waste generation between the products is relatively smaller. The polyp trap is a larger product, that uses more material, and subsequently generates more waste. Figure 4.5.9 shows another factor contributing to the polyp traps relatively high CF. The material production share of its lifecycle is quite high, compared to other factors, such as manufacturing, transport and disposal. This means that the polyp trap uses relatively high impact materials. In figure 4.5.10, the impact per material used for the polyp trap

can be seen. It clearly shows, that Styrene Acrylonitrile (SAN), the transparent plastic used for the container of the poly trap has the highest environmental impact. Secondly, the silicone tubing has a relatively high impact. Thirdly, Polyurethane has a high CF for the Steris E-trap, but a relatively lower CF for the other models, as the eTrap uses an entire polyurethane drawer, whereas the other models only use the material as a gasket. Materials used for the drawer of the EndoSafier and the ThomasTrap, such as Polycarbonate and Polyethylene have a lower, but still significant share of the polyp traps CF. Except for the Steris eTrap, which uses a PET blister rather than a bar as packaging, the packaging materials have a relatively low share in the polyp traps CF.

### Distribution of environmental impact

Figure 4.5.11 shows some insight on the environmental impact of the polyp trap. The eco-costs for resource scarcity and carbon

footprint are significantly higher compared to those of eco-toxicity and human health.

### Decreased use of formalin cups

As visualised in figure 4.5.4, smaller 30 mL formalin cups can be used instead of larger 50 mL cups in three out of four times. The

use of both smaller and larger cups as opposed to the traditional use of only large cups, leads to a significant decrease in waste generation (see figure 4.5.7). There is a smaller yet still apparent difference in CF as well (see figure 4.5.8).

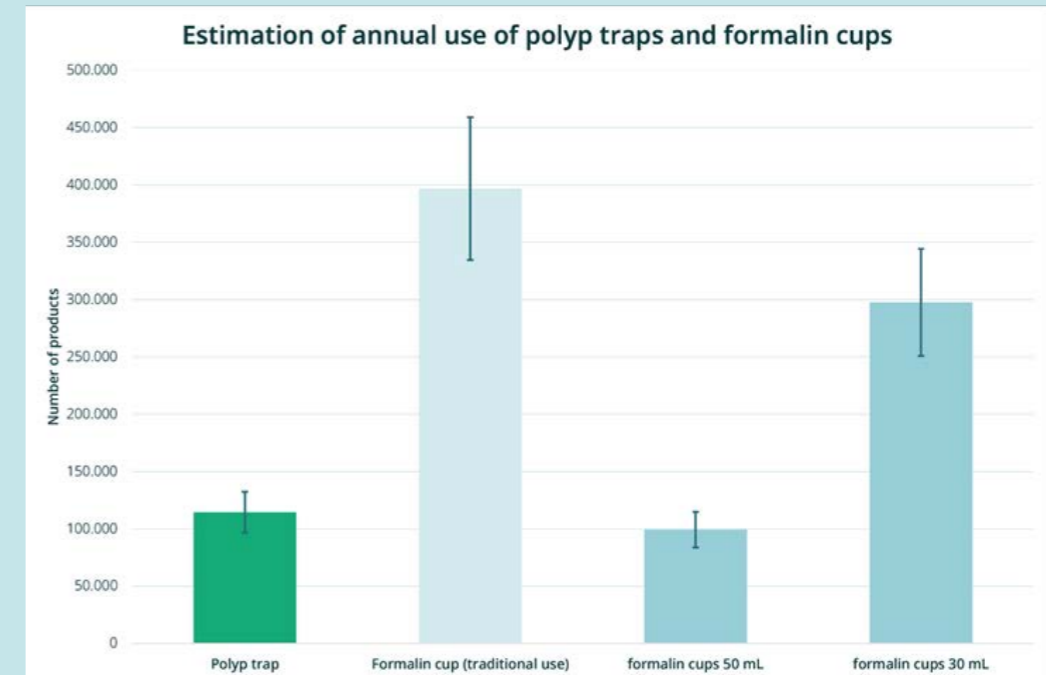

Figure 4.5.6: Estimation of the annual use of polyp traps and formalin cups in the Netherlands.

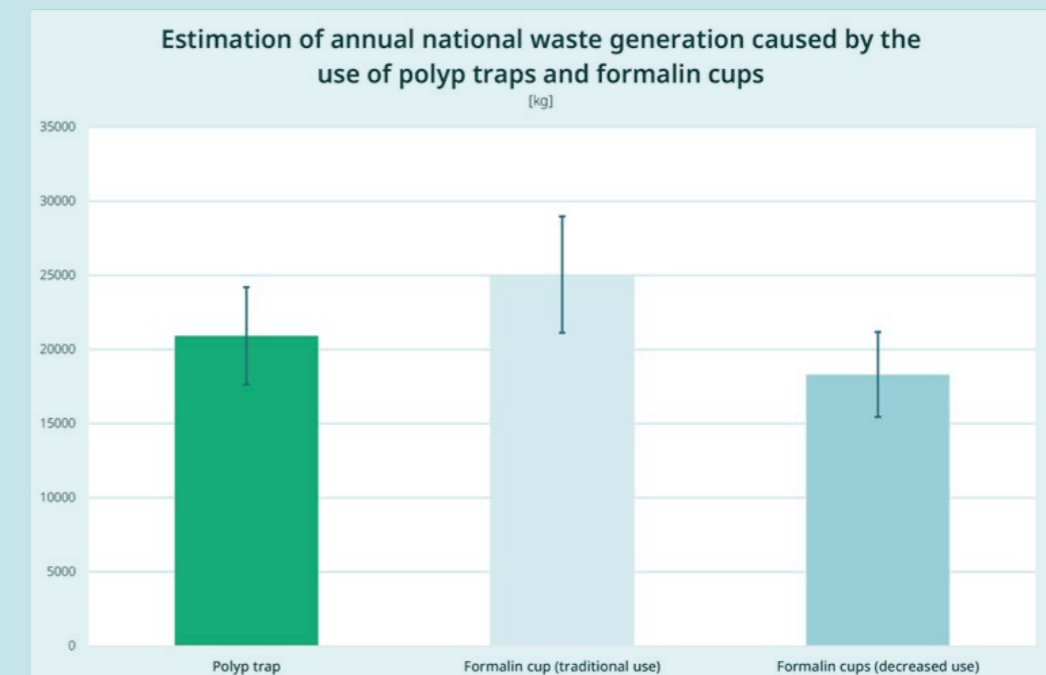

Figure 4.5.7: Estimation of the annual waste generation caused by the use of polyp traps and formalin cups in the Netherlands.



### Estimation of national annual CF caused by the use of polyp traps and formalin cups

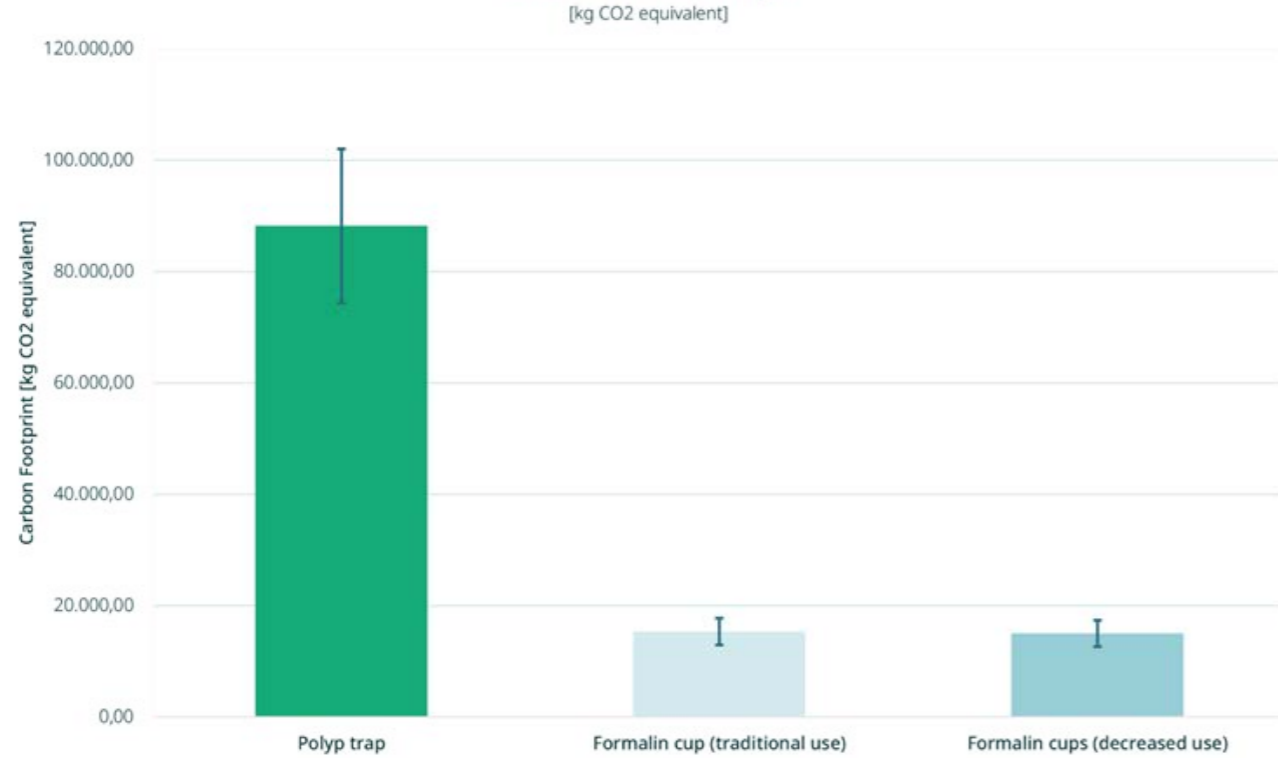

Figure 4.5.8: Estimation of the CF caused by the use of polyp traps and formalin cups in the Netherlands.

### Estimation of distribution for various processes in the lifecycle of various polyp traps

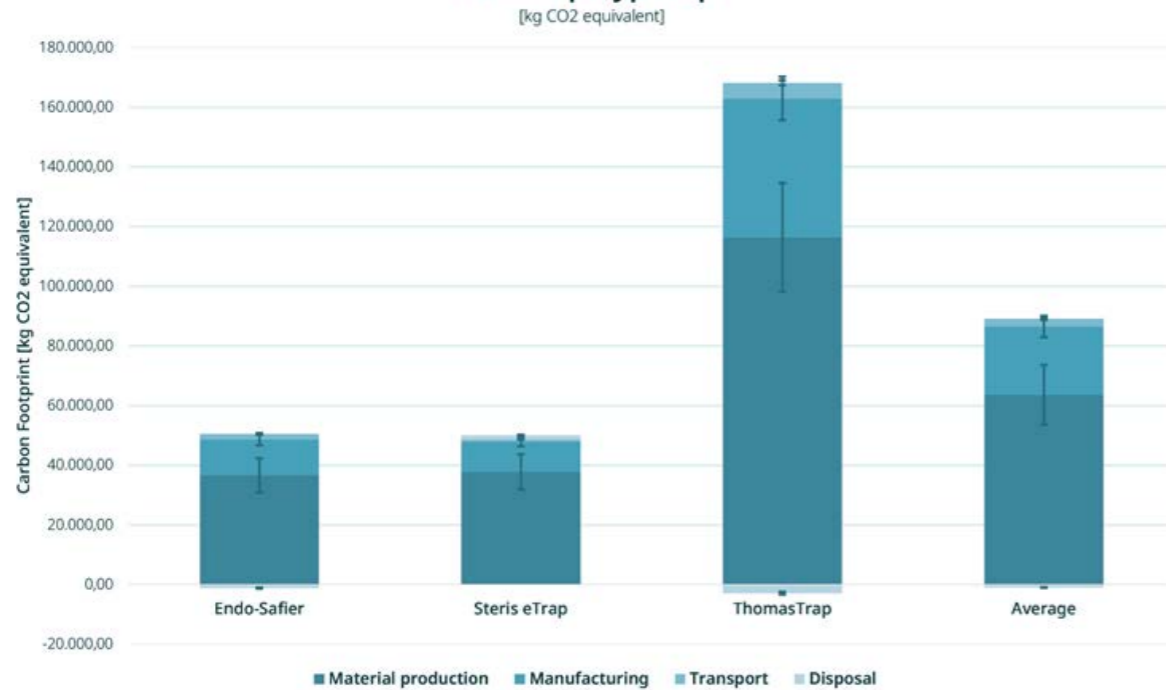

Figure 4.5.9: CF of the polyp trap, divided into various processes in its lifecycle.

### Distribution of CF of material production for various polyp traps, per polyp trap

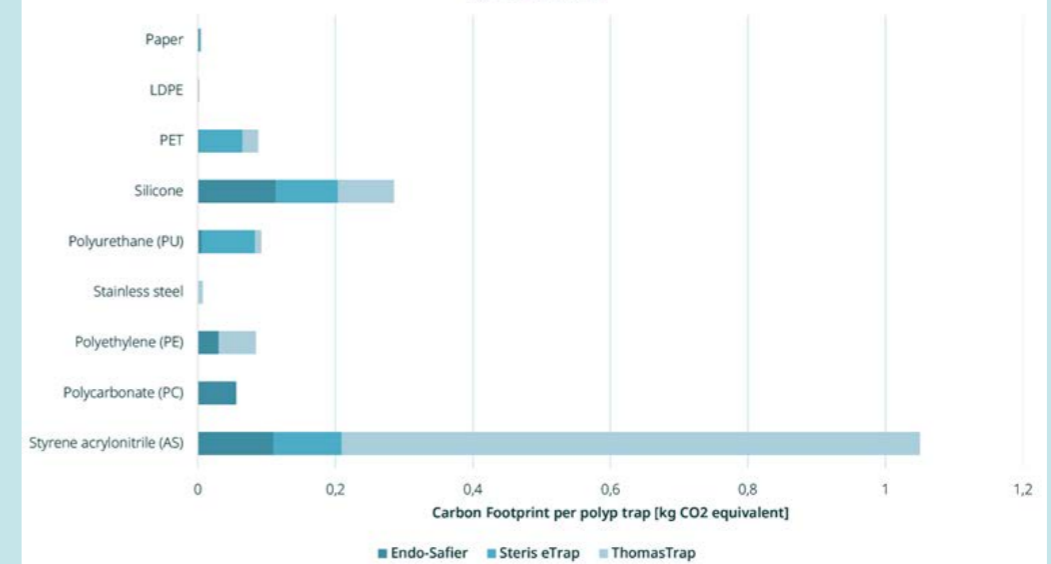

Figure 4.5.10: Carbon footprint of materials used for the polyp trap.

### Estimation of annual eco-costs for various polyp traps

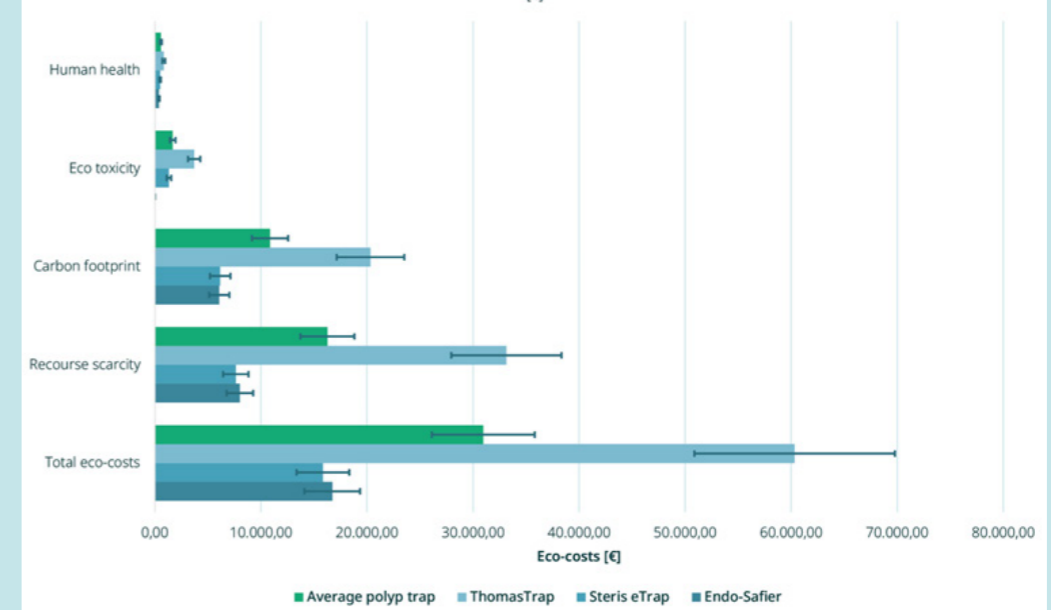

Figure 4.5.11: distribution of eco-costs.

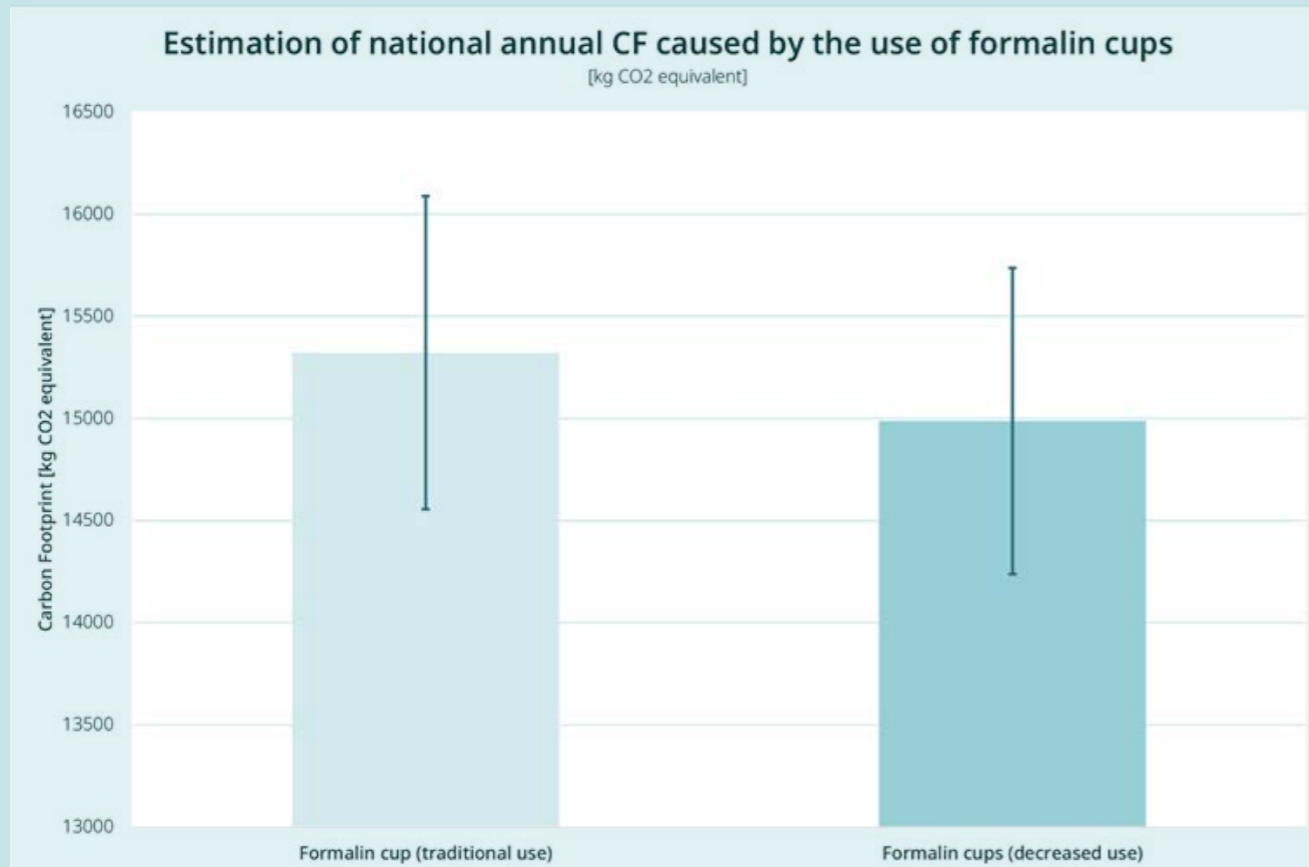

Figure 4.5.12: Carbon footprint for the traditional use of 50 mL formalin cups compared to the decreased use of 50 mL and 30 mL formalin cups

## Discussion

As mentioned before, there are quite some limitations to this fast track LCA. First, the estimation for the national use is based on the limited amount of information available. This limits the accuracy of this estimations. Additionally, the materials for two of three polyp traps is unknown, and therefore also based on an estimation. Lastly, the idemat (2023) database is based on multiple other databases and sources of information, which in terms could limit its trustworthiness. Due to the limited timescale of this project however, using this database enables the possibility to make a fast-track LCA, as retrieving and reviewing data through academic papers would have been unrealistic. These limitations should be taken into account when reviewing the results. Therefore, the focus is on comparisons of values rather than on the values themselves.

When looking at the distribution of eco-costs, the polyp traps main environmental impact, seems to be material extraction and carbon footprint. However, when looking at the context of the polyp trap as only one of many SUD used during a procedure, the effects of waste production should not be underestimated. As discussed in the introduction, this is a factor that substantially contributes to the healthcare sectors environmental footprint.

Compared to the polyp trap, the CF of the formalin cup is significant, but relatively lower. This is somewhat unexpected, as about 3.5 times as many cups are used compared to polyp traps. When looking at the buildup of the CF of the polyp trap and the formalin cup, this difference is explained. For both products, the production of materials clearly has the greatest environmental impact, compared to other factors, manufacturing, transport and disposal. Therefore, opportunities for a redesign could be reducing material use,

and selecting materials with a lower CF. As the formalin cups use less impactful material, and less material per product in general, their total CF is lower, even though more products are used. Additionally, their waste production and CF can already be decreased through the use of both smaller and larger cups.

## Conclusion

As the polyp trap main environmental impact is material extraction and carbon footprint, it is important to select a redesign strategy that not only decreases the Carbon Footprint of the polyp trap, but also improves the circularity of the polyp trap, decreases its reliance on fossil based plastics, and reduces the impact of waste generation.

As the environmental impact of formalin cups is generally lower compared to that of the polyp trap and the existing reduce strategy could already significantly reduce their environmental impact, the focus of this project should be on redesigning the polyp trap. Secondly, the redesign should take into account that the CF of the polyp trap is mainly caused by material production. Therefore strategies that use lower impact materials, reduce the amount of material used, prolong the lifetime of the product, and therefore its materials, or use non-fossil based materials should be explored while redesigning the polyp trap.

## Design guidelines:

- Circular strategies that have the most potential to severely decrease the polyp traps environmental impact, are reuse, reprocess, and rethink.
- As the environmental impact of the polyp trap is much larger than that of the formalin cups, the focus should be on redesigning the polyp trap, rather than the cups, or rather then integrating the cups and the polyp trap.
- For all three polyp traps, the container is a component with a large share in its carbon footprint. Therefore, decreasing this components CF through minimising it's size and selecting a material with a lower carbon footprint, could significantly decrease its overall carbon footprint.
- In the Steris eTrap, the flexible tray has a

quite significant carbon footprint compared to the other polyp traps with hard plastic drawers. Therefore, a hard plastic tray, combined with a gasket should be preferred over the soft flexible tray.

- The tube is a component with a relatively high environmental impact, therefore, minimising the length of the tube is desirable.
- When comparing the environmental impact of the packaging, LDPE bags are less impactful compared to the blister packaging of the Steris eTrap. Therefore, this type of packaging should be preferred.



*In this chapter, a circular framework will be selected to categorise and analyse various circular strategies. Literature research is used to gain insight in these strategies within the context of medical SUD and answer the following research questions: How can existing circular frameworks be used to outline potential circular strategies for the context of medical SUD? How could these circular strategies be applied to the polyp trap? How can circular strategies be used to redesign medical SUD such as the polyp trap in a more sustainable way? Through various fast-track LCAs, the effect of applying different circular strategies to the polyp trap will be analysed, thus answering the following research question: How would applying different circular strategies to the current polyp influence the environmental impact of the polyp trap?*

# 5. Circular Strategies

## 5.1 Circular frameworks

The increasing reliance of the medical sector on SUD shows that there is a need for application of sustainable design in the healthcare sector. (Kane et al., 2017). The inherent wastefulness of the frequent use of SUD disregards the value of raw materials, the energy consumption and environmental burdens that are caused by production (Kane et al., 2017). Therefore, to truly reduce the environmental impact of SUD, a circular approach needs to be considered. Several circular models exist, that visualise the flow of materials and everchanging value of a product in a circular business model, such as the Butterfly Diagram by the Ellen Macarthur Foundation, and the Value hill. In this chapter, Circular models will be introduced, and sustainable strategies based on this model will be explored in the medical context, and specifically to the Polyp Trap.

### The Butterfly Diagram

The Circular Economy Diagram, or Butterfly Diagram, is a model representing the flow of materials in a circular economy. The two sides of the cycle represent the technical and biological cycle. When (re)designing a product in a circular economy model, the aim is to maintain the value of the product, or its materials. The larger the loop, the more energy needs to be added to the system, to recapture the value. Therefore, the smaller inner cycles should be prioritised, and recycling should only be considered as a last resort (Ellen Macarthur Foundation, n.d.).

### The Value Hill

This fluctuating value is specifically visualised in the value hill. The Value Hill is shows how a products value changes over time. Value is added to a product as it is designed, produced, distributed and

sold. As the consumer uses the product, it's value decreases. In a linear model, this value drops as soon as the product becomes obsolete. In a circular model, the value can be retained through Re-use, refurbishing, remanufacturing and recycling, or the more complete in terms of systemic change, Refuse, Rethink, Reduce, Repair, Remanufacture, Repurpose, Recycle, Recover (Achterberg et al., 2016). For this specific context, an adaptation of the classic value hill was made. In chapter 5.2, these adapted strategies are explained further (see adapted value hill in figure 5.1.1). This circular strategy clearly outlines the different circular strategies, while taking design strategies such as refuse and rethink into account. Additionally, it clearly visualizes the loss of value that takes place for strategies at the lower end of the hill. Therefore, this framework will be used to map out the various circular strategies in this project.

## 5.2 Circular strategies in the medical context.

### Infection risk and complex medical devices

When designing for the medical context, infection risk is a factor that should be taken into account (Kane et al., 2018). Endoscopy are non-or minimally invasive procedures. The infection risk of minimally invasive surgery is generally low compared to open surgeries, as

there is less contact with sterile tissue which is vulnerable for infections. Furthermore, they reduce recovery time for patients, as no or only a small incision needs to be made. These types of operations are possible due to technical innovations in the field of medical instruments and the development of laparoscopic and endoscopic instruments. The

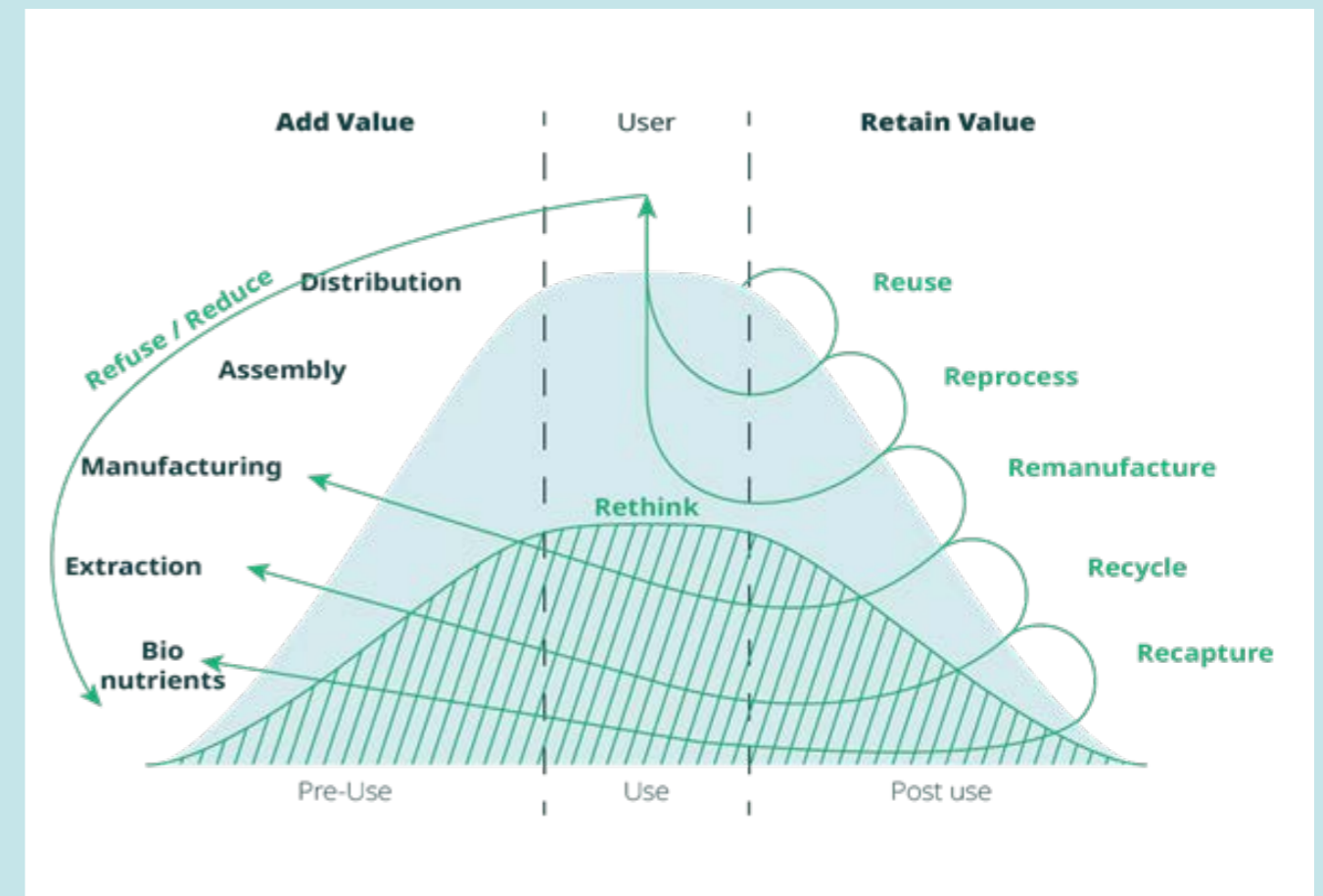

Figure 5.1.1: Adaptation of the value hill aimed at the redesign of medical SUD.

endoscope is a complex product, that consists out of different materials, mechanical, and electronic components. It has two stainless steel spiral bands, a wire mesh, and several wires that enable steering of the tip of the insertion tube, and adjustable stiffness. It also has several channels that transport water and CO2 in and out of the cavity, a camera and a light channel (see figure 5.2.1) (Raju, 2022) (Gastro training, n.d.) (Radiology key, n.d.). Unfortunately, this complexity makes devices such as the endoscope extremely hard to decontaminate. To illustrate, the

decontamination, the decontamination, or reprocessing process of an endoscope contains about 100 individual steps. Combined with growing resistance against disinfection and sterilisation chemicals and higher tolerance to environmental stresses of microorganisms, this leads to a high risk of infection (Rowan at al, 2023). This might explain that infection prevention personnel is generally cautious toward sustainable interventions or alternatives, as they could influence the infection risk (P3; P5; P7, see appendix D)



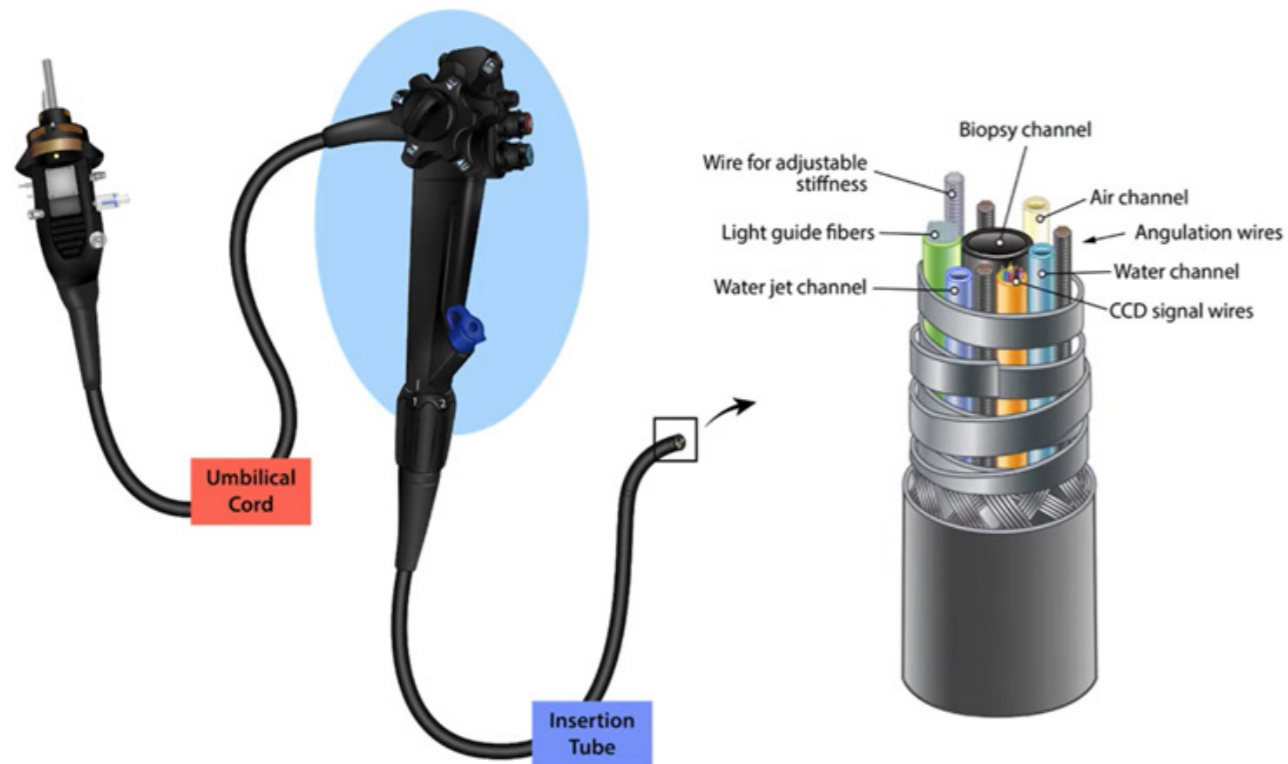

Figure 5.2.1: An endoscope (Raju, 2022).

### Reprocessing and hygienic obsolescence

The risk of infection and associated mitigation actions cause a hindrance for reuse strategies for medical devices and SUD. There are two methods of dealing with this risk. The first option is to decontaminate the product before re-use through reprocessing. As mentioned before, reprocessing is a complex process. Additionally, it can be energy intensive and the process relies heavily on chemicals (Kane et al., 2018). As reprocessing is such an impactful and integral part of the reuse strategy, I have added it to the adapted value hill, which I will use to frame different circular strategies (see figure 5.1.1).

The second option is using SUD. In the past decades, medical device producing companies have pushed for the use of SUD over reusables, due to the lower infection risk (Kane et al, 2022) (Elta & Law, 2020), and the lucrative revenue model that SUD generate. Additionally, more complex products, such as

the duodenoscope, a specialised endoscope used for ERCP (endoscopic retrograde cholangiopancreatography), an endoscopic procedure that diagnoses and treats diseases of the pancreas and bile ducts, are increasingly designed as SUD (Elta & Law, 2020)(Sloan, 2007). The medical function of this category of products has therefore let to a unique type of premature obsolescence: Hygienic obsolescence (Kane et al., 2018).

### Selecting a fitting strategy

In the research paper 'Towards design strategies for circular medical products', Kane et al. (2018) defines the main factors that determine recovery opportunities as financial viability. Based on these factors, the following framework is proposed (see figure 5.2.2):

To find the polyp trap's relative placement in this matrix, we need to determine its criticality and price. The polyp trap does not come into contact with sterile tissue and mucous membrane, or in any direct contact with the patient. Therefore, it is not a critical product. However, bodily fluids do flow through the polyp trap, therefore its inside will become contaminated. Additionally, as the nurse using the polyp trap also inserts the endoscope, the outside is also contaminated. Therefore, for any circular strategies, the infection risk should be considered.

As only the critical side of the matrix takes the challenges caused by contamination into account, the polyp trap should be positioned right to the centreline, and fits best at the left end of the right side of the matrix. Secondly, the retail price of the polyp trap in the Netherlands, varies between six to nine euro's (Meditec, 2023). This makes its value lower than a catheter, yet higher than a single use compression sleeve. Combining these insights, leads to the placement of the polyp trap in the bottom right quarter of the matrix (see figure 5.2.3).

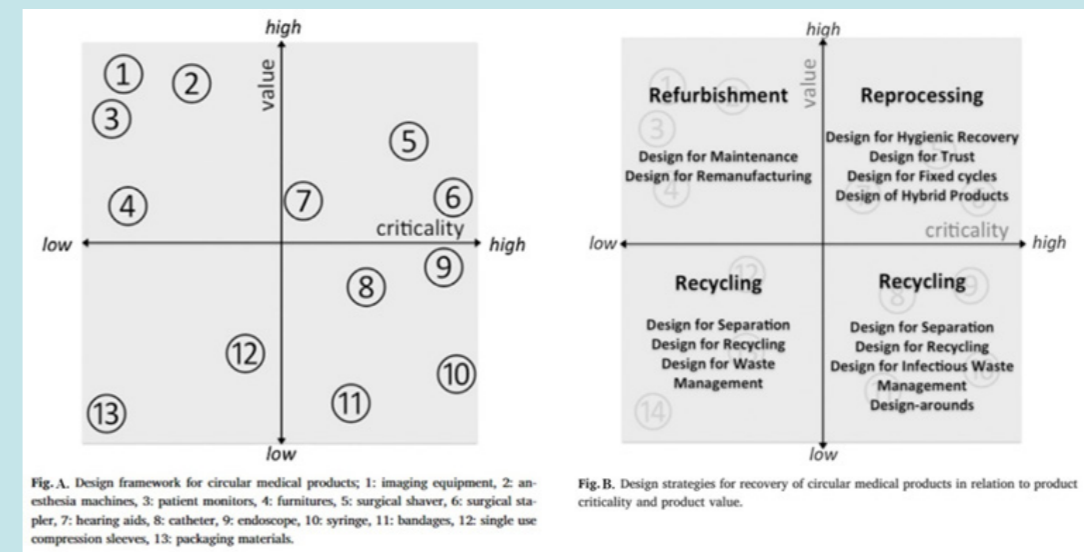

Fig. A. Design framework for circular medical products; 1: imaging equipment, 2: anesthesia machines, 3: patient monitors, 4: furnitures, 5: surgical shaver, 6: surgical stapler, 7: hearing aids, 8: catheter, 9: endoscope, 10: syringe, 11: bandages, 12: single use compression sleeves, 13: packaging materials.

Fig. B. Design strategies for recovery of circular medical products in relation to product criticality and product value.

Figure 5.2.2: Design framework for circular medical products.(Kane et al., 2018)

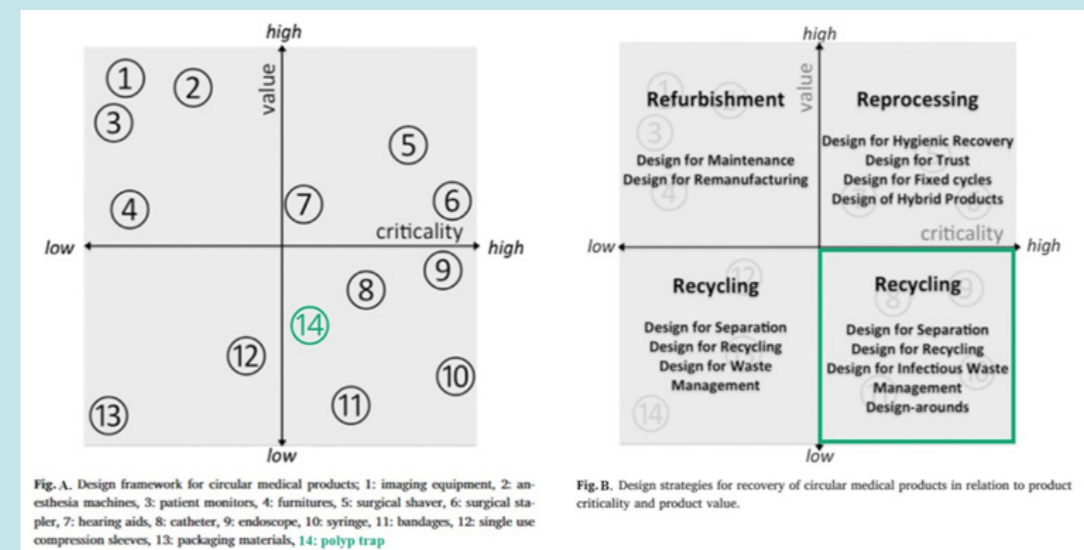

Fig. A. Design framework for circular medical products; 1: imaging equipment, 2: anesthesia machines, 3: patient monitors, 4: furnitures, 5: surgical shaver, 6: surgical stapler, 7: hearing aids, 8: catheter, 9: endoscope, 10: syringe, 11: bandages, 12: single use compression sleeves, 13: packaging materials, 14: polyp trap

Fig. B. Design strategies for recovery of circular medical products in relation to product criticality and product value.

Figure 5.2.3: Design framework for circular medical products (Kane et al., 2018). Adapted with the placement of the polyp trap.

As the paper proposes to recycle products and devices in this category, you could say that I can end my exploration phase here, and design a polyp trap that is highly recyclable and deals with the risks associated with infectious waste. Unfortunately, it is not that simple. Although recycling the polyp trap would be an improvement on the hospital specific waste stream, there are various obstacles and opportunities to consider.

First, there is the problem that currently, HSW cannot be recycled due to regulations, infection risk and technological shortcomings in disinfection technology. As explained earlier in chapter 3.5: Waste streams. Secondly, reprocessing and refurbishing might be too expensive to apply to a relatively low value product as the polyp trap, but strategies such as rethink, refuse

and reduce could still decrease the products environmental impact before its end of life. Lastly, as the polyp trap, as is a non-critical product, it only needs low- to intermediate level disinfection. Additionally, it is relatively simple. It has with no to very little mechanical parts, and reprocessing the polyp trap would require less processing steps, and should be less labour and energy intensive compared to more complex and critical devices such as endoscopes, or laparoscopic instruments. Additionally, the consequences of a failing polyp trap would be negative, but in most cases, not disastrous, as the polyp trap does not come into direct contact with the patient. Therefore, the high costs of reprocessing compared to the relatively low price of the polyp trap might make it unlikely to reprocess, but the possibility could be worth considering.

### 5.3 Circular strategies applied to the polyp trap

#### Refuse/Reduce

There is some overlap in the terms refuse/reduce and rethink. In this report, I will refer to refuse/reduce to the decreased use of existing products and devices, and approach rethink as a redesign strategy. This also means that the refuse/reduce strategy is less relevant to the polyp trap itself, and more relevant to products interacting with the polyp trap. As mentioned in chapter 4.1, polyps used to be caught on a patch of gauze. Although this does still happen at times, to spare time when there is only one polyp to remove, or a very large polyp needs to be caught, this is not according to protocol. As it creates an infection risk for nurses, and a risk of loss of sample for the patient, it is not desirable to return to this situation (P2, see appendix D).

There are still some improvements to be made concerning the packaging of the polyp trap. The single bag LDPE packaging is preferred by nurses (P1, see appendix D), as it uses the smallest amount of material and less space during transportation and disposal. Therefore, it is preferred over a double bag, and especially over a PET blister packaging.

Additionally, the retrieval stickers could be supplied separately, or on request, as not every nurse uses them. Lastly, the label size varied between polyp traps. Obviously, a smaller label uses less material and would therefore be more sustainable.

Apart from these small alterations to the product itself, endoscopy departments can do a lot to decrease their amount of waste, by critically looking at protocols. In the Groene Hart ziekenhuis for example, they added a second, smaller 30 mL formalin cup to the endoscopy suite. After implementation, the smaller formalin cup was used in 75% of cases (P5, see appendix D).

#### Rethink

##### Shape optimisation

Different approaches could be taken to the rethink strategy concerning the polyp trap. The first approach is optimisation: Redesigning the polyp trap to minimize the amount of material used. One way to achieve this, could be through reducing the wall depth (see figure 5.3.1). In figure 5.3.5, the CF for a polyp trap with a wall depth decreased from

1.75 to 1 is visualised. Appendix F shows the calculation for this CF. Minimization of the polyp trap could also be approached, through shortening its length (see figure 5.3.2) or depth (see figure 5.3.3), or through a radical redesign of the product (see figure 5.3.4). With a radically different design, the amount of steps required to connect it to the endoscope and catch polyps should be

similar, or decreased compared to the current polyp trap. As the process of a polypectomy is supposed to be very efficient, a redesign of the polyp trap that would take more time to operate would not be successful. For these approaches, some research is required in the design phase concerning how much material can be omitted.

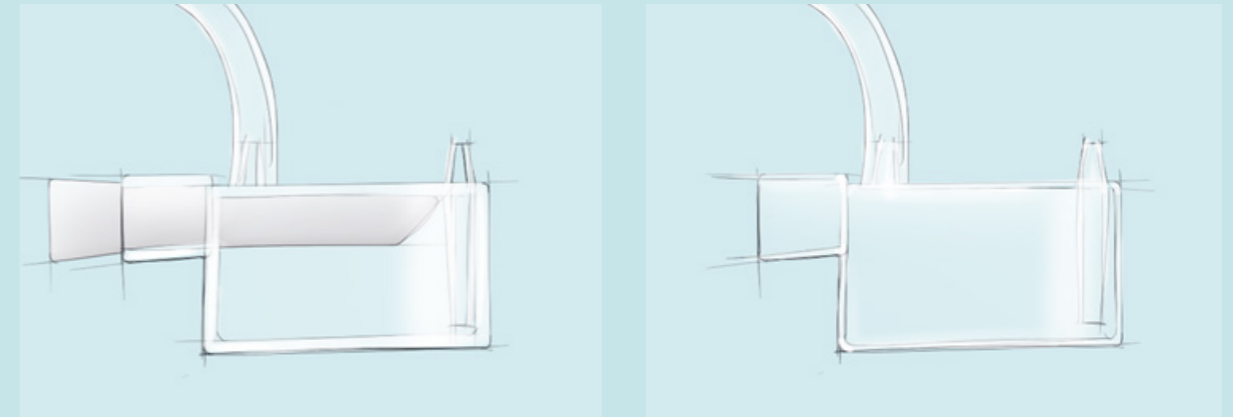

Figure 5.3.1: Normal polyp trap and polyp trap with minimised wall depth.

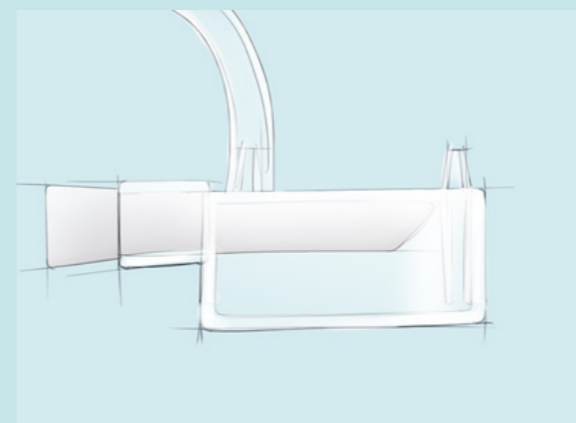

Figure 5.3.2: Container with decreased depth.

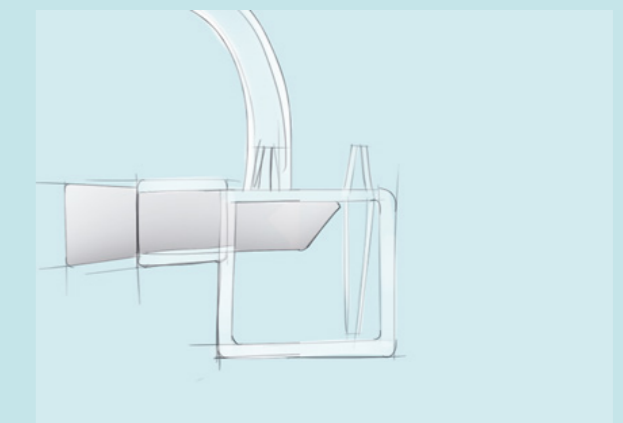

Figure 5.3.3: Polyp trap with decreased drawer length.

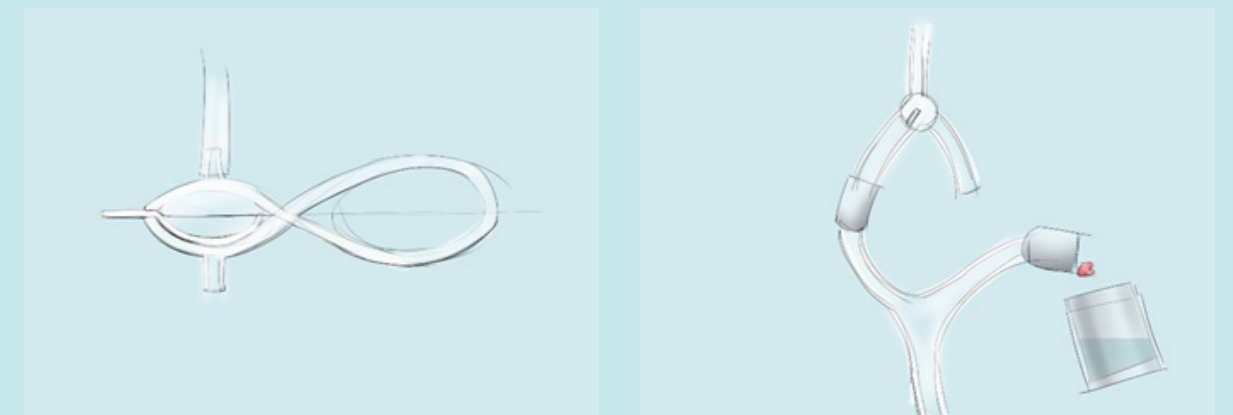

Figure 5.3.4: Examples of radical redesigns of the polyp trap



### Material optimisation

Secondly, the product can be made from a different material with a lower environmental impact. This could be a traditional fossil-based plastic, or a bio-based plastic. The new material should be able to fulfil the same function as the current material, and should therefore have somewhat similar material properties. This is especially crucial for the container, as it needs to have a glass-like transparency to enable the nurse to check whether the polyp is collected. Furthermore, the part needs to be stiff enough to withstand the suction of the pump. In figure 5.3.6, the stiffness of various alternative container materials is compared. Visualisations of CF for potential alternative materials for the container and the drawer are visualized in figure 5.3.7 and 5.3.8 respectively. The carbon footprint for an alternative fossil based plastic polyp trap, a bio-based polyp trap and a bio-based and bio-degradable polyp trap can be found in figure 5.3.5. Calculations leading to these CF can be found in appendix F.

#### *Fossil-based alternative*

As shown in figure 5.3.6, PET, PS, and PMMA all have relatively similar elastic strength compared to the current material. Additionally, both PET and PS also have a lower CF. For the drawers, the materials PE and PP could be interesting replacements. Further research would be required to determine which replacement material would be most suitable, what a different material would mean for the structural integrity for the design, and what the price difference would be. To visualize the possible decreased carbon footprint, a polyp trap made from PET and PP instead of AS, PC and PE is compared to various material options and the current polyp trap in figure 5.3.5.

#### *Bio-based alternative*

To decrease the reliance on fossil based plastics, It could be interesting to consider bio-based plastics. Bio-based plastics are plastics derived from renewable feedstock. There are novel bio-based plastics, such as PLA and PHA, but also drop-in plastics such as bio-PE and bio-PP, that have identical properties to the fossil based variants (Bakker & Balkenende, 2021). The carbon footprint for

a bio-based and bio-based and biodegradable polyp trap are visualised in figure 5.3.5. For the first variation, bio-PE has been selected as a substitute material for the drawer (see appendix F). In the second variation, PHA replaces the materials of both the drawer and the container of the polyp trap (see appendix F). A critical sidenote here is that the amount of LCA research on bio-based and bio-degradable plastics is limited (Bishop et al., 2021). Results of these LCAs differ depending on if and how factors such as additives in the material, carbon storage and end of life have been measured (Bishop et al., 2021). Results of LCAs regarding bio-based and bio-degradable plastics can therefore vary between 200 and 400% depending on what factors are taken into account (Walker & Rothman, 2020). Consequently, it would be unwise to select either a fossil or bio-based plastic purely from the results of a fast-track LCA.

### Redesign

As it depends strongly on the redesign of the product what degree of material reduction is possible, this option cannot be calculated until a concept for a redesign is made.

### Re-use & reprocessing

Most medical products that undergo reprocessing are reusable, but the practice of re-using SUD also exists, especially for highly complex and valuable SUD. Although this could be a more sustainable and economical use of such devices, there are also risks. As SUD are not tested for multiple uses, reprocessed devices could fail and harm the patient. Furthermore, there are no standardized processes in place to reprocess specific SUD, which could lead to insufficient decontamination, and infection risk. There is currently very little regulation in place concerning this practice (Kane et al., 2018).

The polyp trap is a relatively inexpensive device, which might make it less viable to reprocess. However, when integrated into the cleaning process of the endoscope and its accessories, it might be logistically feasible. Additionally, it is a low criticality product,

as it does not come into direct contact with the patient. Therefore, the infection risk is relatively low. The cleaning process of the endoscope starts by flushing the endoscope with water and air while it is still connected to the endoscope processor (P2; P5, see appendix D). During this process, the polyp trap could stay attached to the endoscope, simultaneously completing its pre-processing. After pre-processing, the endoscope and its accessories are transported to the CSA or internal sterilisation department to be dismantled and pre-cleaned in detergent, with a (disposable) brush (P4; P5, see appendix D) (Bhatia et al., 2021)(Beilenhoff et al., 2018). The polyp trap would need to be disassembled in three parts; the tube, container, and the drawers. The drawers might be more difficult to clear of debris, due to their small holes. Therefore, pre-processing is essential to properly disinfect the component.

After pre-cleaning, the endoscope and its accessories will be sterilised in an autoclave. An autoclave cleans medical devices using hot steam. As the materials used in the polyp trap have a proficient resistance to high temperatures and sterilisation agents (HCL Technologies, 2013), little to no alterations would be necessary to redesign the polyp trap for sterilisation. However, plastics are known to degenerate after withstanding high temperatures (HCL Technologies, 2013). Therefore, there is a chance that it would break, or start to leak. This could make the product less reliable, and create infection risk for nurses handling the device. To prevent this, the polyp trap could be marked after each use, and disposed of after a fixed, safe amount of use cycles. However, this is yet again an additional step that would be added to the reprocessing cycle.

After the endoscope and its accessories are dried to prevent re-growth of bacteria, and stored (P4; P5, see appendix D) (Beilenhoff et al., 2018). It would not be practical to store the polyp trap with the endoscope, as not every endoscopy requires a polyp trap. Therefore, the polyp trap needs to be brought back to the endoscopy suite. As a reusable polyp trap might enable the hospital to have less

polyp traps in storage, this could prevent the movement from storage room to endoscopy room, saving preparation time for nurses. Lastly, a new way of packaging the reusable polyp trap would need to be developed.

To compare the carbon footprint of the current disposable polyp trap to that of a reprocessed polyp trap, I made an estimation of the energy consumption and water use required to sterilize one polyp trap in an autoclave. The electricity and water consumption per sterilised mass of an autoclave is about 1.9 kWh/kg and 58L/kg respectively. For an average polyp trap, this comes down to about 0,17 kWh and 5.1 L wate. In Idemat (2023), this leads to a carbon footprint of reprocessing of 0,12 kg CO2 equivalent. This CF for a reprocessed polyp trap is visualised in figure 5.3.5.

### Reuse

There could be another way to reuse the polyp trap without needing to reprocess it. Certain products used in the endoscopy suite are used for a longer period of time, and for multiple patients. The air and sterile water supply tubes for example, are disposed after a time period between one day and one week, depending on the protocols of the specific hospital (P6 & P7). Another example is the irrigation system, which is used until the waste water bag is full, whereafter it is disposed of through the hospital specific waste stream (P7). It could be interesting to consider whether the polyp trap could also be used for one day, rather than for one patient. As the polyp trap does not directly contact the patient, similarly to the waste water bag, the added risk would be minimal. To minimize this risk even further, a check valve could be added to the inlet of the polyp trap. Similarly to the check valves connected to the air and water inlet tubes, this would prevent any residual water to enter the sterilised endoscope of a new patient.

Another risk could be that residual polyp tissue from a previous patient could lead to incorrect result for the next patient. Therefore, a more realistic scenario would be daily reuse of only the container, and disposable drawers. As the polyp tissue

normally lands in the drawer, disposable drawers would prohibit most polyp tissue from staying in the container. There are incidents where polyp tissue sticks to the container rather than the drawer. To avoid that this influences test results, the container could be flushed with water between patients, clearing it of residual tissue. As this is already part of the pre-cleaning process for the endoscope, this would not add additional tasks for the nurse. However, some kind of lid would need to be added to the container in to be able to flush it an inserted polyp trap. In figure 4.3.5 CO2 footprint for the reuse scenario of the container is visualised. In this scenario the possible addition of a check valve or a lid has not been taken into account. Still, the both waste production and carbon footprint of daily reuse of the container, saves about a quarter of the impact of the current impact.

#### Re-manufacture

Remanufacturing or refurbishing for medical devices is mainly implemented for highly complex, expensive machinery, such as X-Ray or MRI machines. Remanufacturing for critical devices happens rarely, and only with medium complexity instruments (Kane et al., 2018). As the polyp trap is a relatively simple, low complexity device, collecting and repairing devices will likely be more expensive than buying them new. Additionally, in almost every case, the polyp trap becomes hygienically obsolete before it breaks, therefore remanufacturing would mainly entail decontaminating the product. Lastly, there is not a lot to repair. Plastic parts could be exchanged if they would start to leak, at which point it becomes questionable if the impact of producing a new device still outweighs the additional impact from the remanufacturing process and the new part. To conclude, remanufacturing is not a suitable circular strategy for the polyp trap.

#### Recycle

##### Regulation

Currently, regulations determine that hospital specific waste must always be incinerated with the condition that all infectious materials are completely destroyed (Rijkswaterstaat,

2021). To meet this condition, hospital specific waste is incinerated at a higher temperature compared to general waste. Furthermore the waste stream is optimised in a way that requires no direct human interaction. Hospitals load their infectious waste in containers, and these containers are incinerated (Milieu Service Nederland, 2023). Although energy recovery does take place when incinerating hospital specific waste, similarly to general waste, the incineration at a higher temperature, causes disposal of hospital specific waste to have a higher carbon footprint. As it is unclear how much higher this CF is, this is not taken into account in the fast-track LCA.

##### Decontamination

There are methods of decontaminating HSW. In the Netherlands, two different methods are currently applied. The advantage is, that less strict regulations apply after decontamination. The waste stream must still be incinerated, but the condition that infectious material needs to be destroyed through incineration no longer applies. Therefore, it can be incinerated in similar circumstances as general waste, requiring a lower temperature, and less risk mitigation activities. However, the waste stream must still be strictly separated from the general waste stream (Rijkswaterstaat, 2021). The main advantage for hospitals, is that disposing costs after decontamination are lower. This is due to lower fees due to decreased risk, and decreased total volume of waste, as decontaminated waste is typically shredded. This results in lower transportation costs. (Milieu Service Nederland, 2023). Another advantage could be that the CF is lower, due to lower incineration temperatures, lowered transport impact, and re-use of containers rather than incineration. However, as no data concerning the environmental impact of decontamination is available, it remains unclear how much the CF is decreased through decontamination.

Decontamination is not used at a large scale yet in the Netherlands. UMC Utrecht uses a technique called Sterilwave to decontaminate part of its hospital specific waste in-house. Sterilwave shreds the waste stream into small

flakes, and uses microwaves to heat the waste to 110°C, for 20 minutes. The resulting flakes can be incinerated through the general waste stream, or used as a substitute for sawdust in the cement industry (Hossain et al., 2012). Another decontamination method is through steam. Similarly to autoclaves in which reusable devices are reprocessed, hot steam at high pressure is used to heat waste to a temperature between 121°C - 134°C. Additionally, the waste is shredded. Although this decontamination method is not used in the Netherlands, up to 40 countries in Europe have hospitals that use this system, according to a manufacturer (Celitron, 2023). Unfortunately, research implies that the technique is not suitable for recycling purposes, due to possible regrowth of microorganisms after sterilisation (Hossain et al., 2012).

##### Prevention of hospital specific waste

There are projects where formerly hospital specific waste is recycled, such as the recycling of blue-wrap (van Straten et al., 2021). This mostly concerns waste that has been disposed of through hospital specific waste, even though it has not come into direct, or indirect contact with patients. Although this practice does decrease the hospital specific waste stream, it does so by decreasing hospital specific waste production, rather than recycling hospital specific waste.

By redirecting hospital specific waste streams to general waste, its impact is immediately lowered, as it no longer needs to be incinerated at higher temperatures, and the containers used for collection do not need to be incinerated and can therefore be reused. An additional advantage to redirection HSW to the general waste stream, is that the disposal of hospital specific waste is more expensive compared to general waste. This is due to the infection risks and mitigation activities that need to be applied. Therefore, decreasing the amount of hospital specific waste, saves money. Unfortunately, the polyp trap does come into contact with bodily fluids and human tissue, and therefore causes an infectious risk when disposed of through the general waste stream. For this type of medical devices, there is currently no way

towards recycling. As long as hospital specific waste cannot be decontaminated to a level where risk of infection is evidently absent, and regulation prohibits the practice of recycling infectious waste, recycling of SUD such as the polyp trap will be impossible.

Although there are no specific regulations that prohibit the use of recycled materials in medical products, this is not common practice, as manufacturers tend to avoid unnecessary risks (Commissie voor Volksgezondheid, 2018). However, using recycled materials class I medical devices, such as the polyp trap, might be an acceptable level of risk, as the SUD does not come into direct contact with the patient. As the Idemat (2023) database only contains information about chemically recycled plastics, this data is used as input. However, using mechanically recycled material could be possible as well. As this process is less energy intensive, the estimation in figure 5.20 could be too high. Secondly, the CO2 footprint for recycled SAN is not described in the Idemat (2023) database, therefore, recycled ABS was chosen as a placeholder, as the materials are closely related.

##### Recapture

An interesting way to recapture value from material, is through biodegradable plastics. Biodegradable plastics are able to degrade back to nutrients. There are many variations in biodegradable plastics, most of which are bio-based as well, although some are fossil-based. Their degrading capabilities also vary. PLA is at times called biodegradable, even though its degradation is slow, and it does not completely break apart to nutrients. This varying degree of degradability can be cause for confusion. Additionally, recycling facilities have trouble filtering the material. As there is currently no regulation or structure for biodegradable plastics collection and disposal, bio-degradable plastics mainly degrade the recycling stream, and end up being incinerated anyway. As mentioned before in, hospital specific waste must be incinerated. Therefore, composting infectious waste made from biodegradable material, is not an option. However, there is a way to recapture



energy from bio-materials under current legislation, with Pharmafilter. Pharmafilter is a system that processes and decontaminates hospital specific waste. It is currently used in five hospitals in the Netherlands, in Delft, Terneuzen, in two hospitals in Rotterdam and in Zaanstad (Waterforum, 2019). Pharmafilter is a water filtration system, focused on filtering medicine residue. It is designed as a solution to complex and inefficient waste streams in the hospital. Hospital specific waste is disposed of through the sewer, together with waste water. Waste is shredded and filtered from the waste water. The waste water will undergo a filtration process, that will remove microorganisms and medicinal waste. Resulting sludge from the waste water is fermented into methane gas, that is used to generate energy. The shredded waste materials are disposed of through hospital specific waste directly, or are decontaminated before being disposed of (Rijkswaterstaat, n.d.). Furthermore, Pharmafilter sells biodegradable plastic bedpans and urinals, that can be fermented as well (Pharmafilter, n.d.). The difference between fermentation and composting, is that that fermentation takes place in the absence of oxygen. Bio-

degradable plastics, such as PLA and PHA are able to produce biogas through fermentation (Vasmara & Marchetti, 2016). Therefore, this could be an interesting way to recapture energy in a more efficient way compared to incineration. However, the system is not without critique (Waterforum, 2019). Zaans Medisch Centrum, a hospital that has already implemented the system, connects an outbreak of a the resistant bacteria in 2018, with a flood in the sewer system, caused by a clogging of the waste stream.

The carbon footprint of a biodegradable polyp trap, is visualised in figure 4.3.5. The material chosen as a biodegradable replacement, is PHA, as H&P moulding already has experience working with this bio-based and biodegradable plastic (personal communication H&P moulding, 2023). Although transparent PHA does exist, its exact optical qualities are still largely unknown (Molenveld et al., 2022). As the transparency of the window is a requirement to the polyp trap, using PHA could be a risk. To mitigate this, a separate window could be integrated into the model as a separate part.

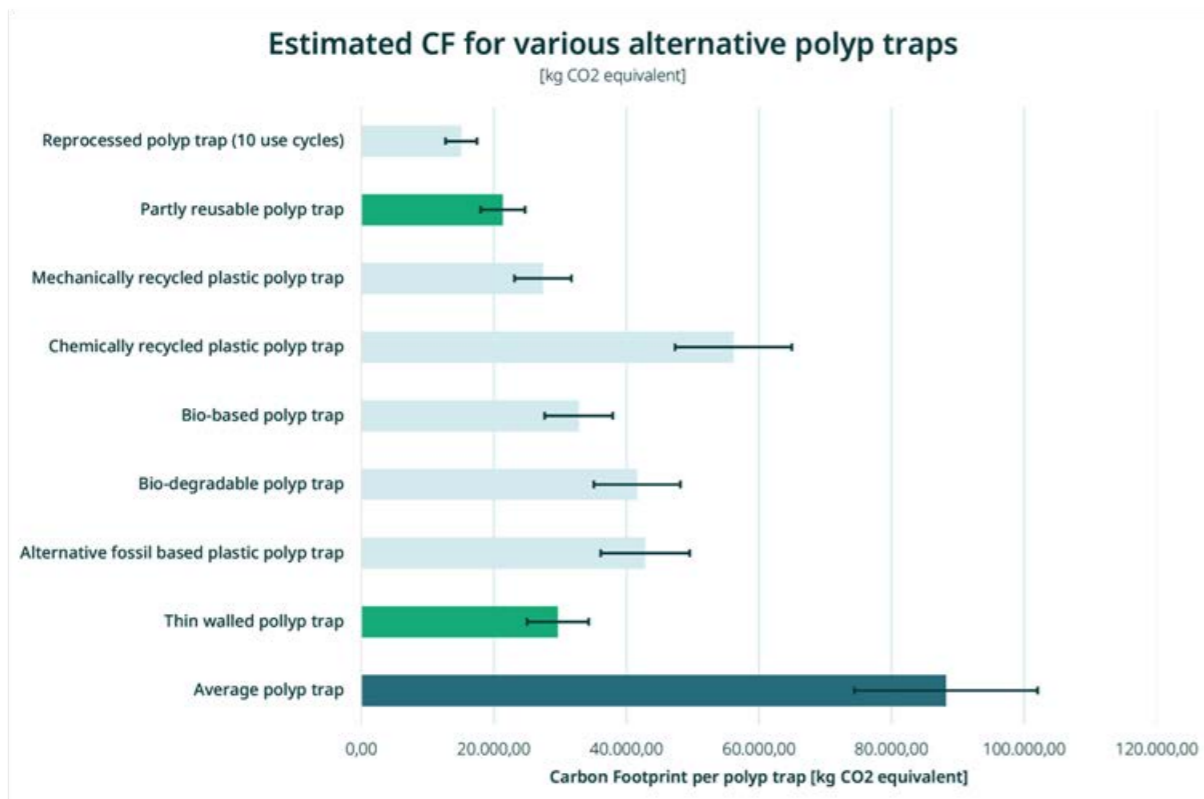

Figure 5.3.5: Carbon footprints for various alternative polyp traps, based on different circular strategies.

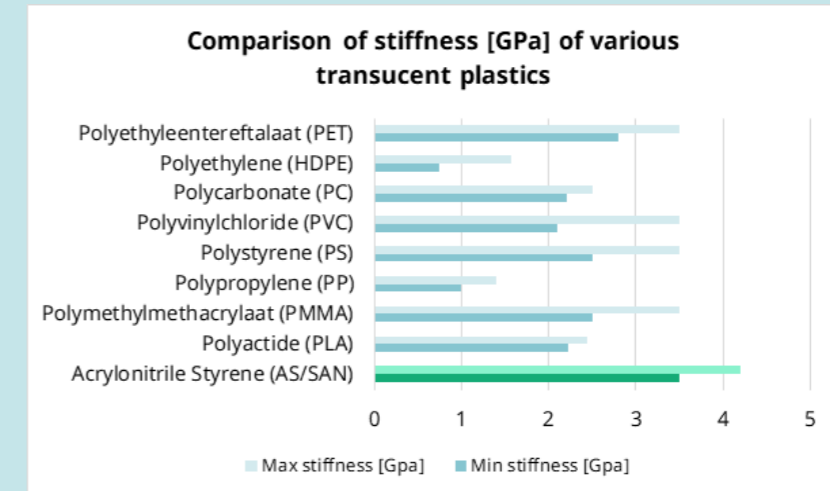

Figure 5.3.6: Comparison of stiffness for varying alternative plastics compared to the plastic currently used for the container.

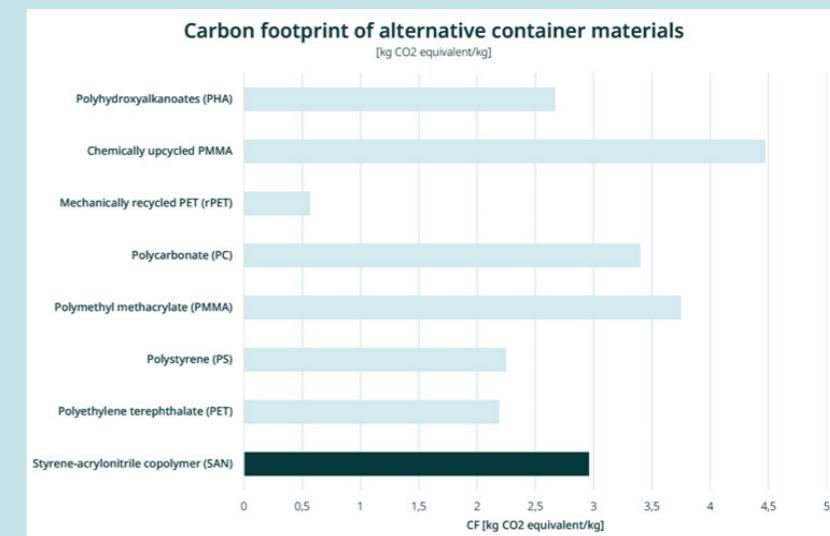

Figure 5.3.8: CF for various alternative materials for the container of the polyp trap.

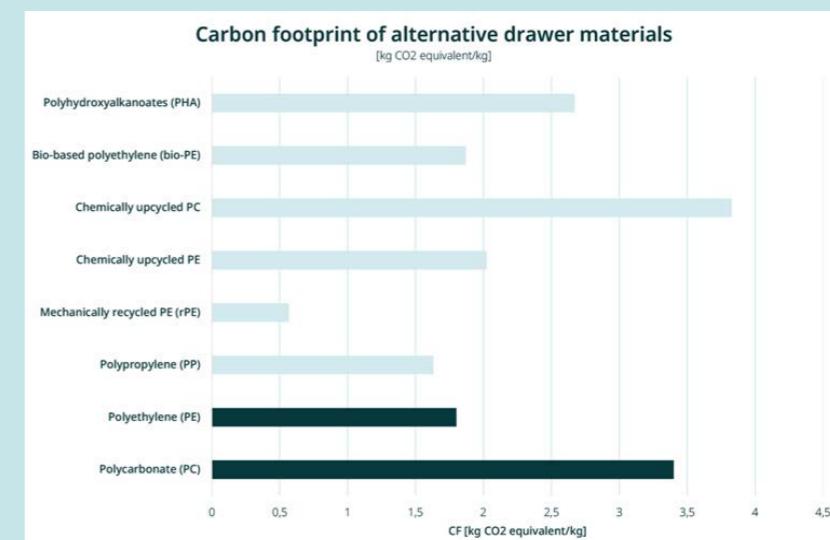

Figure 5.3.9: CF for various alternative materials for the drawer of the polyp trap.

## 5.4 Conclusion

Realistically, there is no fitting alternative end-of-life strategy to incineration for hospital specific waste in the near future. Even if regulation would allow recycling or bio-degradation of materials, technology for sufficient decontamination is currently not proficient. This first step towards a more circular medical specific waste stream, is a quite recent development, which only a small number of hospitals in the Netherland has adopted. Moreover, there is little research performed on the decontamination grade of decontaminated medical waste, and the research that is available deems it unsuitable for recycling (Joseph et al., 2021). Additionally, most decontamination machinery shreds disposed materials into fine flakes. As hospital specific waste is currently not separated, the separation of different materials would be a second challenge for recycling.

The fermentation of bioplastics to methanol could be an end-of-life strategy that is at the least somewhat more circular compared to incineration, and one that is already being used at several hospitals in the Netherlands. However, there are still quite some disadvantages to consider, such as the infection risk, and the separation of regular plastics from biodegradable plastics. Additionally, there are only five hospitals in the Netherlands that use this system, and the possible, yet unproven causal relationship with an outbreak of resistant bacteria could hinder further adoption of the system.

Therefore, specifically designing the polyp trap for either recycling or biodegradation would not have an immediate effect on its end of life. Although the use of biodegradable-plastics could currently make the polyp trap more circular for the few hospitals that use a fermentation system, it should not be a spearpoint for a redesign of the polyp trap, as the redesign should also be a sustainable solution for hospitals without the system.

Therefore, the strategies that remain are Reuse and Rethink. For the next phase in this project, ideation and conceptualisation, I

would like to use these two strategies as two possible directions.

### **Reuse**

The CF of both a reprocessed and a reusable polip trap is quite low. However, as mentioned before, due to the relatively low value of the polyp trap, reprocessing will be an unlikely scenario. Additionally, the reprocessing strategy requires logistical adjustments to the endoscope cleaning process, and additional tasks for the nurse and cleaning personnel, the 24 hour use scenario, that requires minimal additional tasks, would therefore be more realistic. As mentioned before, there are still some challenges within this strategy. Therefore, these challenges will be explored, and through ideation. The ideas from this process will be discussed with a nurse, and infection prevention. Based on this discussion, ideas will be selected for conceptualisation, or the idea direction will be discarded.

### **Rethink**

For the rethink direction, it would be interesting to combine a material with a lower carbon footprint with a optimisation of the shape of the polyp trap. Additional research will be required to determine suitable replacement materials. Furthermore, the material choice will be discussed with Meditec and H&P Moulding. Secondly, I will use ideation to come up with different ways to optimize the shape of the polyp trap. These ideas will be evaluated on their usability through discussion with endoscopy nurses.



*In this chapter, insights from literature research, observational research, and the fast-track LCA will be combined to redesign the polyp trap in a more sustainable way. Through ideation, various concepts are developed, that are evaluated through interviews with healthcare professionals. Prototype tests will be used to evaluate the concept, and further detail it into the final design, presented at the end of this part. With this final concept, the fourth and last research question will be answered: How can the polyp trap be designed in a more sustainable, yet feasible and viable way? To answer this question, the following sub-questions will be examined: How would applying different circular strategies to the current polyp influence the environmental impact of the polyp trap? What is the difference in environmental impact between the current polyp trap, and the redesign of the polyp trap? How would the redesign influence the price of the polyp trap?*

# Part IV

## The Redesign

# 6. Conceptualisation

## 6.1 Interviews

To evaluate the initial ideas generated during ideation and explore opportunities and risks of the idea directions, nurses and experts in hygienic use of medical device are interviewed. The aim of these interviews, is to evaluate if the reuse direction could realistically work, which features could be added to the concept to mitigate the risks that could occur during reuse, and further define what risks occur when reusing the product. For the minimisation direction, the aim is to evaluate the usability of varying shapes and sizes of the polyp trap, and to define potential risks that could occur by changing the shape or size of the polyp trap.

### Method

The main research questions for the interviews are:

- How does re-use of the polyp trap influence its usability?
- How do various variations in shape and size influence the usability of the polyp trap?
- What risks occur when changing the size and shape of the polyp trap, and (how) can they be mitigated.
- What risks occur during reuse of the product, and (how ) can they be mitigated?

During the interviews, these research questions are explored through smaller interview questions, which can be found in appendix G. The questions will be asked based on a presentation of the ideas for both the reuse, and the rethink direction.

During the interviews with nurses, the focus is on the first three research questions. The interviews with the infection prevention and hygienic medical device use expert focus more on the last research question. The adaptations to each interview can be found in appendix G.

### Participants

To evaluate both the risks and the usability aspects to the concepts, Interviews are conducted both with nurses, the direct users, and medical professionals who have expertise in hygienic use of medical devices. Through Meditec, an interview at Acibadem (a clinic in Amsterdam) with an endoscopic nurse (P10, see appendix D). Through contacts from previous observations, an interview with a group of five endoscopic

nurses (P11) was arranged. As this interview was at the hospital, and the transcription was made from recording, identifying individual participants was too complex. Therefore, this group of nurses is addressed with a single participant number, P11.

Through contacts at Windesheim, interviews were arranged with two specialists regarding infection risks. The first is a specialist infection prevention specialist (P12), who is involved with policy regarding infection prevention in Isala Zwolle. Part of this includes judging the materials and products, and how they influence infection prevention.

The second is a specialist sterile medical equipment, whose expertise is on how to use, disinfect and sterilise medical devices and equipment (P13).

### Idea presentation

The reuse and minimisation ideas are presented in two different ways. The reuse concept is presented in a booklet (see figure 6.1.1 to 6.1.3). The main concept is to reuse the container and dispose the drawers after each patient. In the booklet, varying ideas are presented to mitigate the infection and contamination risks that occur with the reuse of the polyp trap.

#### Hergebruik scenario:

Door (een deel van) het poliep opvangbakje dagelijks te gebruiken, in plaats van per patiënt, kan de CO2 Footprint van het product worden verlaagd. Hierdoor ontstaat echter ook een risico op infectie, en een risico op het overblijven van weefsel van de voorgaande patiënt. Op de volgende vijf pagina's zijn verschillende ontwerp aanpassingen te zien die deze risico's zouden kunnen vermijden. Ieder idee bestaat uit herbruikbare delen, en wegwerp delen.

- Het herbruikbare deel van het poliep opvangbakje wordt dagelijks gebruikt in plaats van per patiënt. Dit deel zou je kunnen zien als een verlengstuk van het irrigatiesysteem. Aan het einde van de dag, wordt het herbruikbare deel weggegooid bij het ziekenhuis specifiek afval.



- Het herbruikbare delen worden aangegeven door dit symbool:



- De wegwerpdelen, waaronder de lades, of een deel hiervan, worden per patiënt gebruikt, om het risico op infectie en overgebleven weefsel te verminderen. Dit zijn de 'wegwerp' onderdelen. Aan het einde van een scopie, worden deze delen weggegooid bij het ziekenhuis specifiek afval.

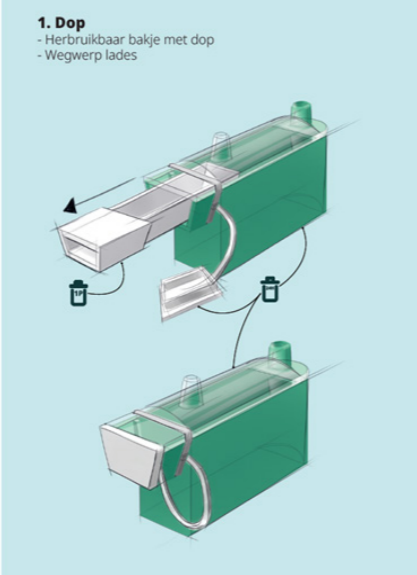

**1. Dop**  
- Herbruikbaar bakje met dop  
- Wegwerp lades

#### 2. Vervangbaar raam

- Herbruikbaar bakje
- Wegwerp raam
- Wegwerp lades

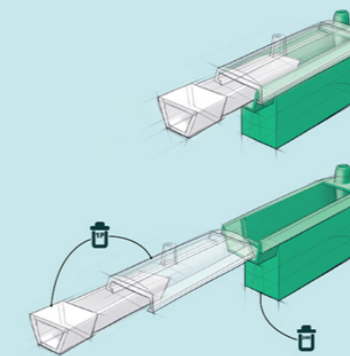

#### 3. Vervangbare inlet

- Herbruikbaar bakje
- Wegwerp lades
- Wegwerp buis & geïntegreerde inlet

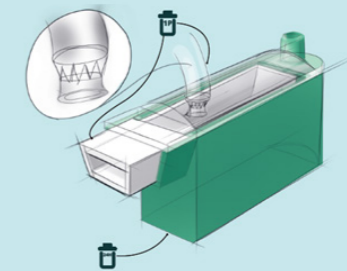
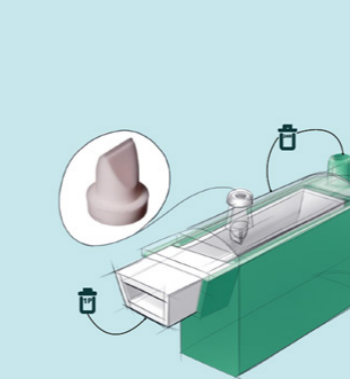

Figure 6.1.2: Booklet re-use ideas page 2.

#### 4. Terugslagklep

- Herbruikbaar bakje
- Terugslagklep



#### 5. Vervangbare zeef

- Herbruikbaar bakje
- Herbruikbaar deel lade
- Wegwerp zeef

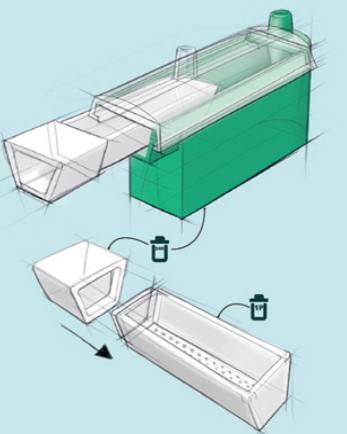

Figure 6.1.3: Booklet re-use ideas page 3.

Figure 6.1.1: Booklet re-use ideas page 1.



Minimisation exploration prototypes  
As there was an opportunity to combine the interview with P10 at Acibadem with using an endoscope setup for prototype testing, various minimisation prototypes were developed through rapid prototyping. To gain input on the minimalization direction and potential difference in the function for varying

shapes and sizes, I 3D printed four prototypes of polyp traps, in varying shapes and sizes. The prototyped were developed with transparent element, using either transparent filament, or a glued in window, to be able to make a first evaluation of the waterflow through the product (see figure 6.1.4 to 6.1.7).



Figure 6.1.4: Low polyp trap prototype with outlet on side connected to endoscope.



Figure 6.1.5: Short polyp trap prototype.



Figure 6.1.6: Low polyp trap prototype



Figure 6.1.7: Slanted polyp trap prototype

## Results

### Risks

#### Sample contamination

The main risk associated with reuse, is contamination of polyp tissue from a previous patient onto the next. This could lead to false positive test results (P10, P11, P12 & P13, see appendix D).

This risk might be mitigated by replacing all components that contact polyp tissue. This comes down to the drawer, and the window (P10, P11 & P13).

“Although the chance that any residual tissue will stick to the window after flushing it is small, there is still a risk. As a false positive result should absolutely be avoided, the product can only be re-used if all parts that come into direct contact with polyp tissue are replaced.” (P10)

Additionally, the endoscope is flushed with water after the procedure, until only clean water returns. During this process, the polyp trap is still attached. This further mitigates the risk of residual tissue (P10, P11). However, there could be a chance that residual tissue from the container could migrate back to the new drawer through the holes in the bottom. This way, contamination could take

place regardless of replacing the drawer and window.

“During suction, droplets and possibly aerosols form, and therefore there is no 100% guarantee that those aerosols and droplets do not contaminate the next patient's tissue if they migrate back from the container.” (P12)

However, another participant (P13) sees this is an unlikely scenario, as both the constant suction and the flushing of the endoscope and the polyp trap in between use would prevent any tissue from flowing in the reversed direction (P13). Still for the infection prevention expert this is a dealbreaker leading to rejection of the concept (P12).

“Some products are simply not reusable” (P12)

### Infection risk

The risk of an infection from the polyp trap onto the endoscope is perceived as small by all participants, due to the constant suction on the polyp trap. As there is no check valve on the wastewater bag, the nurses argued that this would not be necessary for the polyp trap either (P10 & P11).

“As the system is constantly under negative pressure, there is very little risk of contamination towards the patient, and there is no real difference for the reusable container compared to the wastewater bag.” (P11)

However, it could be valuable to have a double barrier, in case the pressure would drop (P12). Another opportunity would be a modular system, where a check valve is only added by high risk patients, such as MRSI patients (P13). Patients with a high infection risk are generally treated at the end of the day, as the whole room needs to be intensively cleaned after the procedure (P13). In this case, this risk would already be mitigated, as the described concept of the reusable polyp trap will be disposed at the end of the day anyway. If a valve is integrated into the polyp trap, it should be replaced after each patient, to prevent tissue

contamination (P13).

Another infection risk could be that the nurse handling the endoscope also touches the outside of the polyp trap. This causes the device to become contaminated. However, all participants agree that this risk could be easily mitigated by wiping the polyp trap along with other contaminated surfaces at the end of the procedure (P10, P11, P12 & P13).

### Usability of reusable polyp trap

The nurses I spoke to all agreed that they would prefer a reusable polyp trap over a disposable product, even if this means additional tasks, such as replacing the window and cleaning the outside of the product with a cloth (P10 & P11). As they already need to clean contaminated surfaces in the room after the procedure, cleaning one additional product would not be an issue (P11).

The nurses participating in the focus group all agreed that a lid would also be essential to the functionality of the concept (P11).

“When the patient needs to be flushed, a lid would be very practical. Without the drawer, the airflow would be interrupted, but with a drawer, it would clog very easily. This would create an unhygienic and inefficient situation.” (P11)

As the patient is normally flushed during insertion of the endoscope, and polyps are removed while retrieving the endoscope (P3), another way to avoid this, would be disconnecting the polyp trap before inserting the endoscope. However, this would require additional actions, therefore a lid might be more practical. Additionally, it could prevent nurses from forgetting to dispose of used trays, and it could save a drawer in case only one polyp needs to be removed. However, the integration of the lid into the drawer, as described in idea 5 in figure 6.1.3, is not desirable, as the nurse would need to touch the sieve part of the drawer, which is normally avoided (P11).

Another necessity to the concept is that the

polyp trap would need to be flushed with water in between use. However, this is also the protocol at the moment, and therefore this requires no behavioural change (P10 & P11).

*“Polyp tissue sometimes becomes stuck in the house of the endoscope. When the endoscope is flushed, this tissue can loosen. To ensure that this residual polyp tissue is preserved, the polyp trap remains connected to the endoscope until after it has been flushed with water. Therefore, the flushing of a reusable polyp trap will not require a behavioural or procedural change.” (P10)*

#### Usability of minimised concepts

It is not relevant to the nurses that the whole container is transparent. As long as the window is transparent and has a magnification function (P10 & P11). Furthermore, the L-shaped prototype (see figure 6.1.4) is preferred (P10, P11), followed by the short prototype (see figure 6.1.5) (P11). The reasoning behind this preference, is simply that these concepts seem to be the smallest, and therefore spare the most material. The nurses expect the smaller polyp traps to work. However, two aspects could be problematic. A smaller drawer might fill up on residue faster, in which case the drawer still needs to have enough draining ability to drain wastewater. If this is not the case, the nurse removing the drawer could have wastewater flowing over them. This same problem could arise if the container is too small to drain proficiently before the nurse removes the drawer (P10 & P11).

*“The drawer is normally never filled with polyp tissue, as this is normally around 5mm in diameter. Larger polyps are removed outside of the polyp trap anyway. It does sometimes become filled with debris, in that case, you would have to test if there is enough space to prevent the polyp trap clogs and floods.” (P10)*

The initial prototype tests seemed to show that the second aspect should not be a problem, as the water seems to flow through the prototypes without pooling. However, whether a smaller container or drawer would

lead to flooding when it is clogged, remains unclear at the moment.

*Connection of prototypes to the endoscope*  
The prototypes initially seem to function as inspected. They do not seem to flood or hinder the flow in any way. There is no significant difference between prototypes, except that some prototypes seem more airtight, due to connection to the walls and glued-in windows and to imperfections in the 3D printed walls. As FDM prints are not perfectly airtight, due to the layered structure it could be interesting to consider alternative manufacturing techniques for the next iteration of prototypes. The gaskets seem to provide an airtight seal. However, the quality of the seal is highly dependent on the pressure with which the drawer is closed. Therefore, a click mechanism could improve the consistency of the seal in future prototypes.

#### Conclusion

The main risk for the reuse of the polyp trap is the contamination of polyp tissue from a previous patient onto the next. This could lead to false positive test results. It is still unclear whether this risk can be sufficiently mitigated.

Additionally, there is an infection risk, that can be mitigated by wiping down the outer surface of the product after each procedure.

The reuse concept leads to some additional tasks for the nurses, however, they do not seem to find the amount of additional work problematic. However, protocols on how the reusable polyp trap is used throughout the day, and how potential mistakes such as forgetting to replace a part can be avoided should be further developed in the concept.

#### Design guidelines

##### Reuse concept

- The polyp trap should have a disposable window and disposable drawers (see figure 6.3.1).
- The polyp trap should have a lid that can be closed, to prevent the nurse has to disconnect the whole product at the start of each procedure (see figure 6.3.1).

##### Rethink Concept

- Only the window of the container needs to be transparent. The sides and bottom of the container can be opaque.
- Minimizing the size of the container does not influence the use of the product. Size limitations are dependent on whether the drawer becomes too clogged to drain water. Further prototype tests are required to determine the minimum size of the drawers and containers.

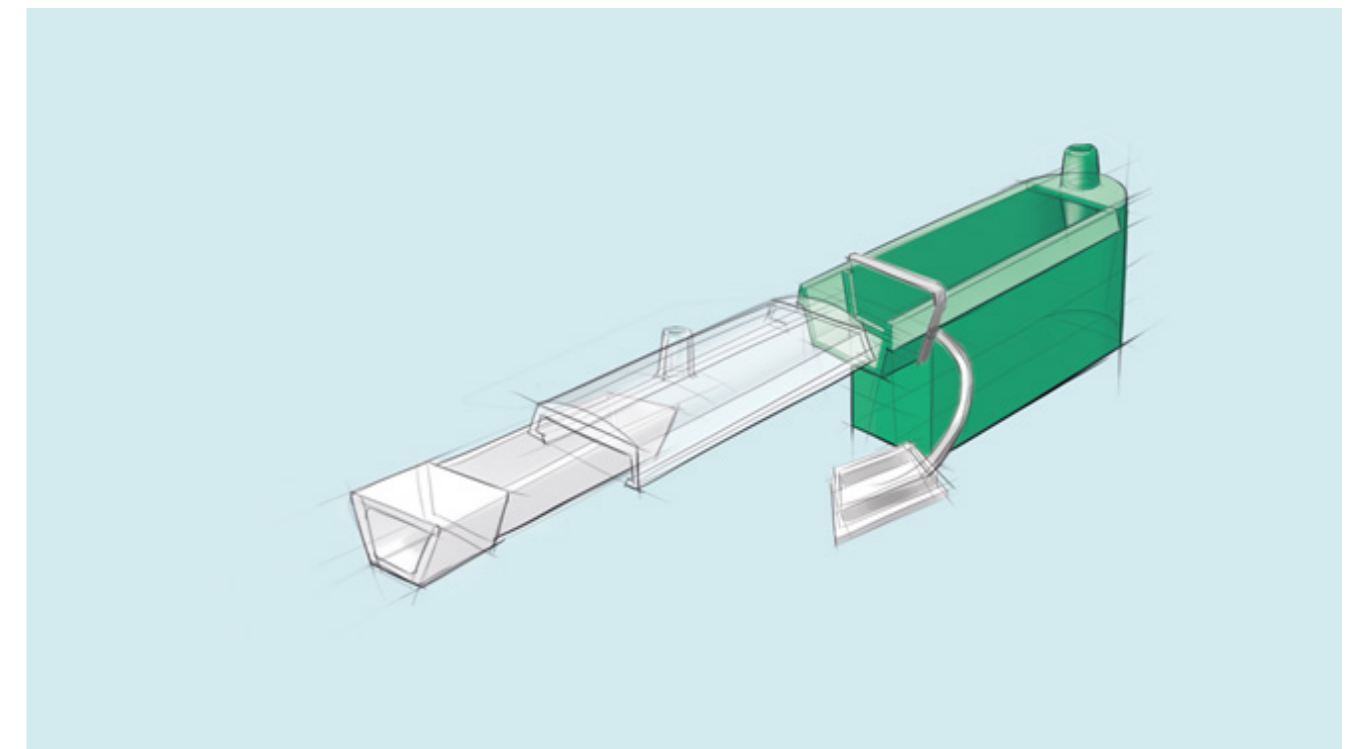

Figure 6.3.1: Polyp trap with disposable window and drawer and disposable container with lid.

#### Discussion & further research

The tissue decontamination risk should be further investigated. Even though this does not seem very likely, the consequences for the patient would be too severe. Therefore, any risk that a sample would be contaminated by residual tissue from the previous patient and cause a false positive result, is unacceptable. To test whether this tissue contamination could take place, the

system should be tested on whether residual tissue is still present in the container after the complete procedure, including the flushing of the endoscope. Additionally, the possibility that tissue inside the container could migrate back to the drawer should be investigated. Lastly, it would be relevant to engage a pathologist anatomist in this research, as they could have valuable insights into the risk of contaminated tissue and false test results.



## 6.2 Prototype tests

To determine the effect of minimalizing the size of the product on the flow of water through the product, I developed and tested four prototypes of containers, and thirteen prototypes of drawers, in five shapes and three different sizes. I compared the degree of clogging, amount of residual water and risk of splashing or leaking to the existing polyp traps. The goal, method, and insights gained from these tests, are described in this chapter.

### Research aim

As changing the shape and size of the polyp trap could affect the working principle of the product, its practicality and safety could be influenced. Through interviews with nurses, three main concerns were identified; potential clogging of the drawer resulting in flooding of the polyp trap due to insufficient filtration area (P10 & P11), flooding of the polyp trap due to insufficient water reservoir in the container, and lastly, the risk of water leaking out of the drawer connection during removal of the drawer. To analyse these risks, and determine design guidelines on the shape and size of the redesign, I defined three research questions.

### Research questions

1. How is the water flow through the product affected by a minimised drawer shape or size?

As described in Chapter 2, debris can enter the polyp trap. When this happens, it is important that the water flow through the product is not blocked in any way. Water should still be able to enter and leave the product to enable the nurse to remove the clogged drawer and empty it. As decreasing the size of the drawer leads to a smaller draining area, the redesigned drawers might lead to a blocked polyp trap.

2. How is the amount of water maximally left in the container influenced by a minimised container shape and size?

Through observational research and interviews (P2; P6 & P7), it became clear that there is never more than a small layer of water left in the product while in use, and it does not become completely flooded. More

residual water could cause an increased infection risk when the nurse removes the drawer or disconnects the container from the endoscope.

4. Is there an increased risk of water leaking or splashing out when removing the drawer for the prototypes, compared to the current product?

In the current product, the wastewater is stored below the drawer, while in my redesign, residual water is stored next to the drawer. This might create a situation where removing the drawer could consequently move some of the water toward the drawer connection. This could result in a risk of wastewater splashing or leaking. This creates an infection risk.

### Method

For each research question, I determined a specific approach.

1. To answer the first research question, I will fill the various drawers of both the current products, and the prototypes with 10 mL jam (see figure 6.2.1) I will then connect the polyp trap with a filled drawer to the setup, to analyse whether the polyp trap becomes clogged and floods, and, if it keeps draining water, how long it takes to completely drain the container.

2. Secondly, I will connect the current polyp traps to the setup, and run the pump until the water level has stabilised. I will then turn off the pump, disconnect the polyp trap, and measure the amount of water left in the polyp trap. I will repeat this process three times for each polyp trap. Additionally, I will repeat this process in a clogged situation, filling the drawers of the polyp traps with 10 mL of jam.

3. To analyse the risk of splashing, I will connect the various current, polyp traps and prototypes to the setup and run the pump until the water level in the polyp trap has stabilised. I will then disconnect the inlet tube from the water reservoir, to pump air through the system rather than water. Waiting until the water has completely drained, creates a more realistic scenario, As soon as the air has reached the polyp trap, the drawer will be removed. At that moment, I will observe whether any leaking or splashing occurs.

### Setup

To test the prototypes in a realistic setup, a peristaltic pump was used, and set at a flow rate of 750 mL/min, similar to an irrigation

pump, used during endoscopy (Olympus, 8272). I acquired this pump at the WaterLab at Civil Engineering, where I could borrow equipment, and build a test setup in the laboratory. Figure 6.2.1 shows an image of the test setup, described below.

The inlet tube is connected to a water reservoir on one end, and held vertically on the other end, by a stand. The polyp trap is connected to this end of the inlet tube. The product is hanging from this tube, similar to a standard endoscopy setting. The outlet of the polyp trap is connected to a tube that is fed through a peristaltic pump. The other end of the tube deposits water into a reservoir. An arm connected to a stand holds the camera, positioned at the polyp trap.



Figure 6.2.1: Polyp traps with 'clogged' drawers.



Figure 6.2.2: Test setup.

### Prototypes

The prototype containers are made from layers of acrylic plate cut out with a laser cutter. The layers are glued together to form a three-dimensional model. 3D printed parts are glued on as in- and outlets. As pilot tests showed that the prototypes still leaked air around the inlet, and the connection to the drawer, these parts have been sealed with silicone sealant. There are three variations of container: An L-shape, a U-shape, a traditional, yet shorter model and finally a

cylindrical model (see figure 6.2.3). A rubber-like material is lasercutted to form a gasket. The drawers are 3D printed and come in four variations of shape, and three variations of size. The shapes are round, spherical, straight, and diagonal (see figure 6.2.4). The diagonal models have gauze rather than ten holes for filtration (see figure 6.2.4). The variations in size are 30, 40 and 50 mm (see figure 6.2.4). Additionally, there is a tray with a smaller handle, and the cylindrical polyp trap comes with its spherical drawer.

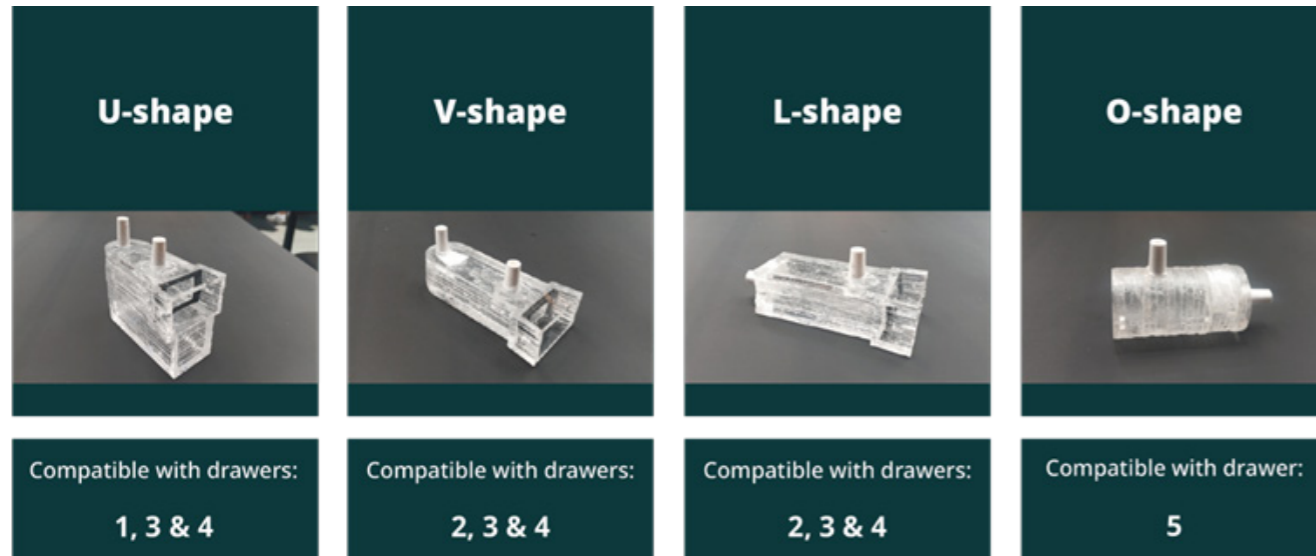

Figure 6.2.3: Second iteration container prototypes.



Figure 6.2.4: Second iteration drawer prototypes.

## Results

1. How is the water flow through the product affected by a minimised drawer shape or size?

None of the prototypes completely flood in a clogged situation (see figure 6.2.5). When the inlet tube is disconnected from the water flow, every prototype empties itself to its minimal level in less than one second, except for drawer 2 (see figure 6.2.5). This variation of shape turned out to have too little draining surface, which presumably caused it to have a longer draining speed.

In the smallest variation of drawers (30 mm long), some leakage occurs around the end of the tray. (see figure 6.2.6). This could cause a risk, as polyp tissue could escape through this misdirected water flow. The same problem occurs if drawer 4 is not inserted horizontally but at a slight angle (see figure 6.2.6).

Lastly, there was no significant difference in draining speed between the gauze drawers, and the straight, or rounded drawers. These insights lead to the following design guidelines:

- The size of the draining surface of the drawer, should have a length of at least 40 mm, and a total draining area of at least 880 mm<sup>2</sup>.
- The application of gauze in the drawer to replace the holes, has no advantage or disadvantage on the flow of water and air through the polyp trap. Therefore, this approach should only be considered if it simplifies the fabrication process of the drawer, and/or has a financial benefit.
- The edge of a slanted drawer model should be supported, to prevent it from tilting, which can lead to an open space between the window and the drawer.

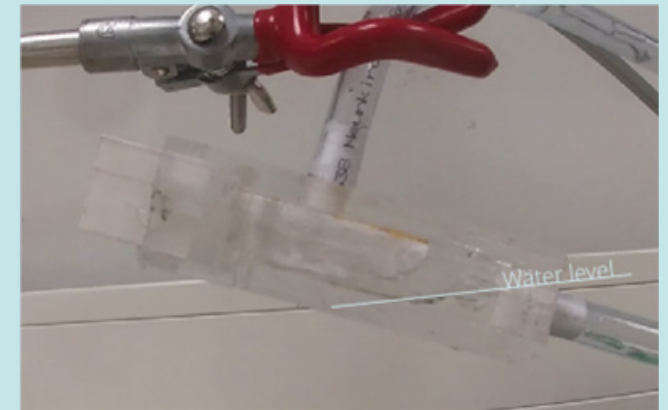

Figure 6.2.5: Waterflow through the clogged prototype.

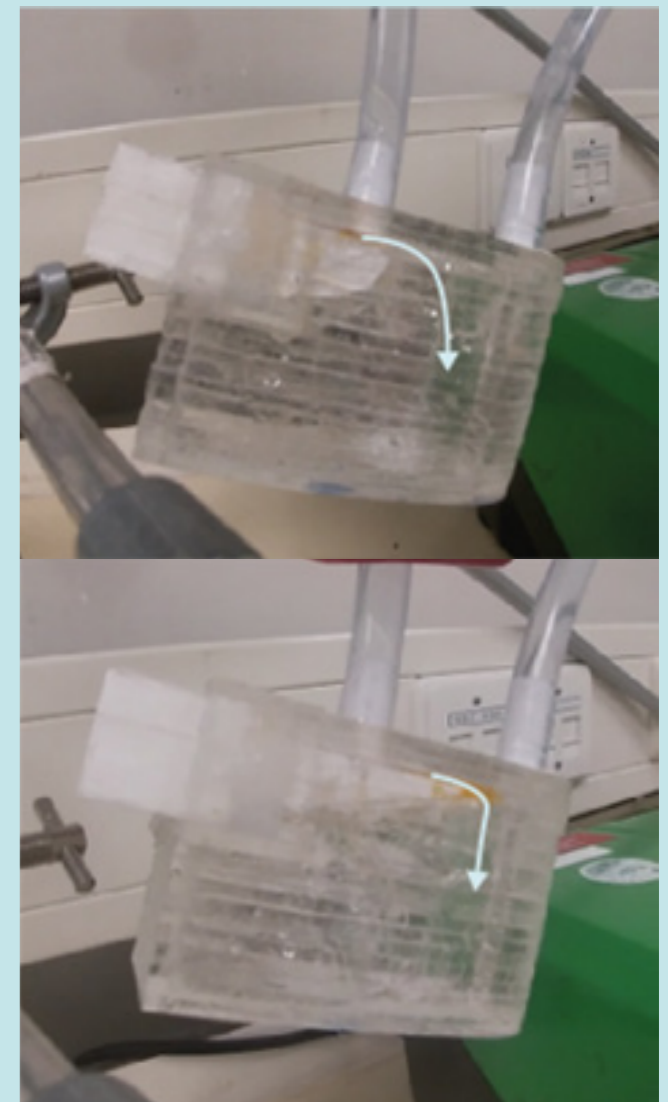

Figure 6.2.6: Water escaping from the end of the drawer.



2. How is the amount of water maximally left in the container influenced by a minimised container shape and size?

The amount of water left in the current polyp traps seems to be partly dependent on the positioning of the outlet. In the current polyp trap, the outlet is positioned on top of the polyp trap, to prevent water leaking from the outlet when it is disconnected from the wastewater tube. It protrudes into the container, leaving a space of about five millimetres from the bottom of the container (see figure 6.2.7). In the prototype containers, the outlet does not completely reach the bottom of the container either, and similarly, this leads to a leftover layer of water (see figure 6.2.8).

In an unclogged situation, the layer of water left in the container fills up the space between the bottom and the outlet. This comes down to about 12 mL. Any excess water is immediately sucked through the

outlet. In a clogged situation, a bit more water is left in the container, presumably because the negative pressure required to suck air through the inlet of the polyp trap is higher compared to an unblocked situation (see figure 6.2.9 and 6.2.10). However, the amount of water left in the polyp trap is still very small, about 16 mL for the current products (see figure 6.2.10). Therefore, the air pressure created by the pump seems to be sufficient to drain water, even if the drawer is full of debris. To conclude, I phrased the following design guidelines:

- a. To minimise the amount of water left in the polyp trap in an unclogged situation, the space between the outlet and the bottom of the container should be minimized.
- b. To prevent flooding of the polyp trap in a clogged situation, the container should be able to store at least 16 mL of water. This space is additional to the volume required to store the drawer.

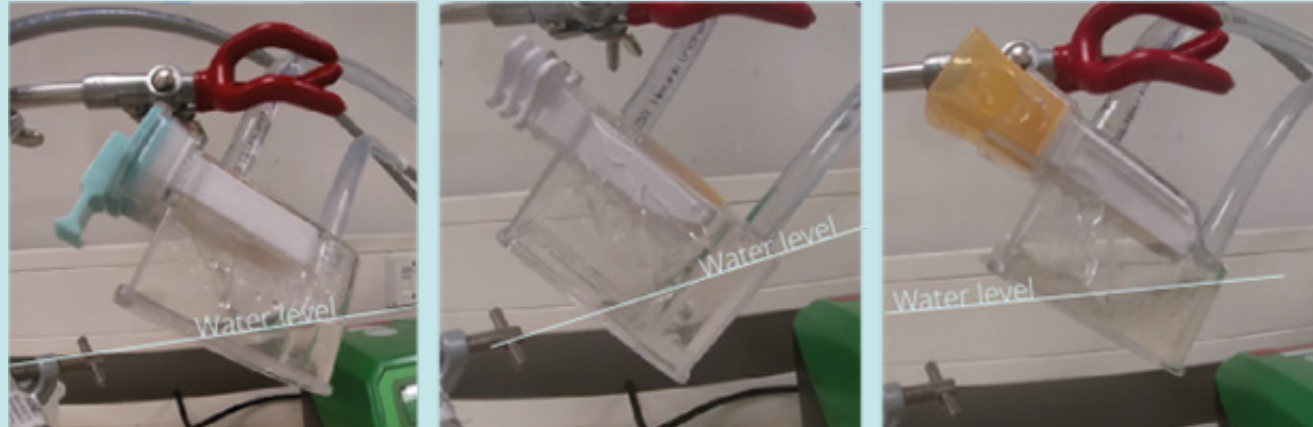

Figure 6.2.9: Amount of water left in a clogged current polyp trap.

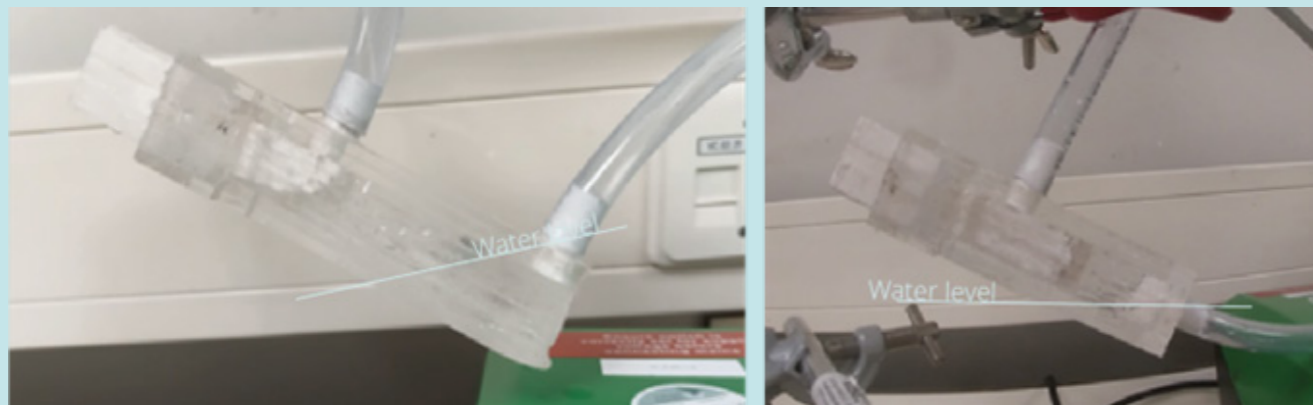

Figure 6.2.8: Amount of water left in an unclogged U and L-shaped container

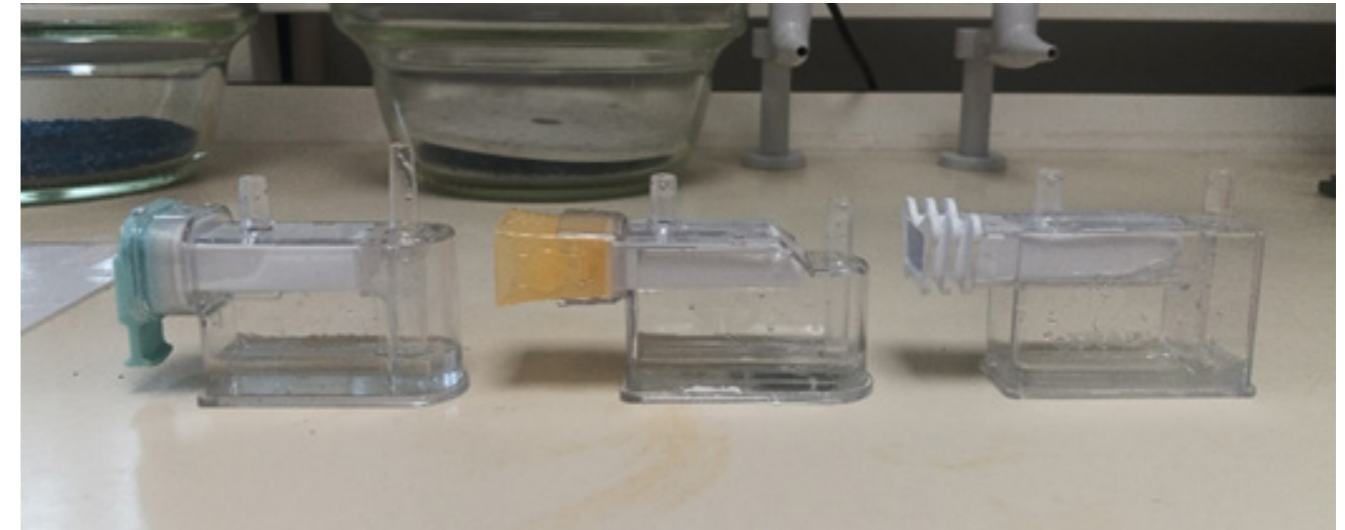

Figure 6.2.6: Water escaping from the end of the drawer:

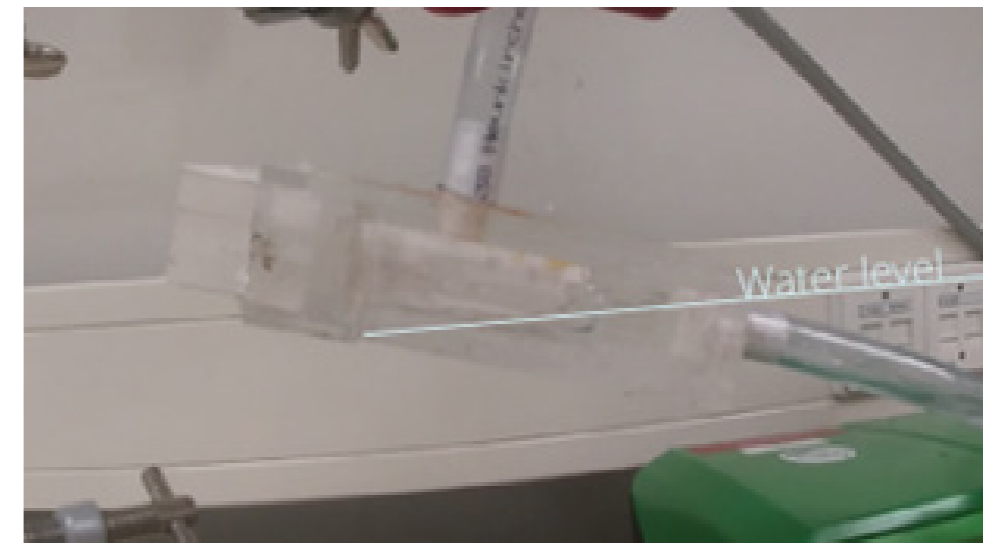

Figure 6.2.10: Amount of water left in a clogged redesigned polyp trap.

3. Is there an increased risk of water leaking or splashing out when removing the drawer for the prototypes, compared to the current product?

During this third test, I noticed no splashing or leaking. Therefore, the variation in the shape of the prototype does not seem to cause a hygienic risk, and no adaptations to the concept are required to mitigate this potential risk.

#### Discussion and further research

For the clogged situation, I used 10 mL of Jam. I chose this amount as it filled the smallest drawers to the brim. However, have no data about how much debris is normally caught, and what the consistency is. This might also differ between, for example, a colonoscopy or a gastronomy. Therefore, the determined drawer size of 40 mm should be tested in real life, and in an ideal situation, during varying types of endoscopy.

# 7. Detailing

In this chapter, the insights and design guidelines gained from the interviews and prototype tests, have been used to create two concepts, one for the idea direction 'Reuse', and one for the idea direction 'Rethink'. In this chapter, the resulting concepts will be presented. Through discussion of the usability and risks, the desirability and feasibility will be explored. The environmental impact of the concepts will be evaluated through a fast-track LCA, and the viability will be analysed through a cost-price calculation. The report will be concluded with design recommendations and a reflection.

## 7.1 Design

### Shape

The prototype tests showed, that changing the shape of the polyp trap did not affect the speed of the water flow through the product, the amount of water left in the prototype, or the risk of splashing. Therefore, the material-efficient L shape has been implemented into the concept (see figure 7.1.3). The polyp trap shape is designed for the way

it is used, connected to the endoscope with a tube. It hangs diagonally which provides an optimised water flow through the product and limits splashing risks for the nurse when the polyp trap is disconnected. As the tube no longer needs to make a 90-degree turn, its length is only half as long compared to the current polyp trap. The outlet of the polyp trap is positioned flush with the bottom, preventing water from staying inside the



Figure 7.1.1: Rethink concept

container (see figure 7.1.5).

The drawer is connected to the container with a click mechanism. It can be opened by pushing the sides of the drawer in, and pulling it out (see figure 7.1.6). A gasket in the polyp trap makes sure that the connection is water and air-tight (see figure 7.1.2). The rounded shape of the drawer optimizes its draining surface, yet provides plenty of space for polyp tissue and its holes are chamfered to prevent clogging (see figure 7.1.8). The drawer rests on a ledge on the side of the container to hold it in position (see figure 7.1.9). The polyp traps' container is 60 mm long and has a drawer of about 40 mm long (see figure 7.1.7). The drawer's slim size allows it to be dipped into a formalin cup, allowing the nurse to remove the polyp without touching the drawer or requiring a retrieval sticker (see figure 7.1.10). The nurse can use the window to check whether the polyp has completely entered the trap (see figure 7.1.11).

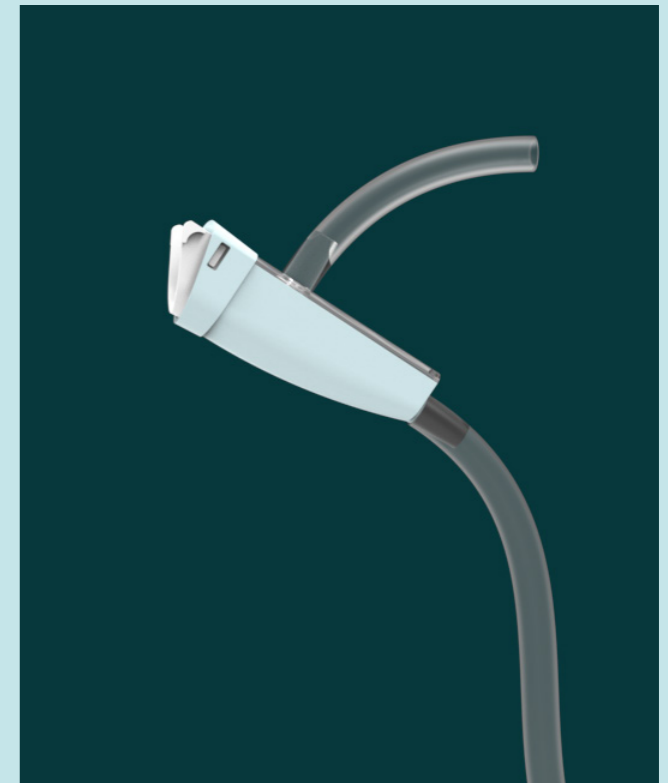

Figure 7.1.3: Sideview of rethink concept.

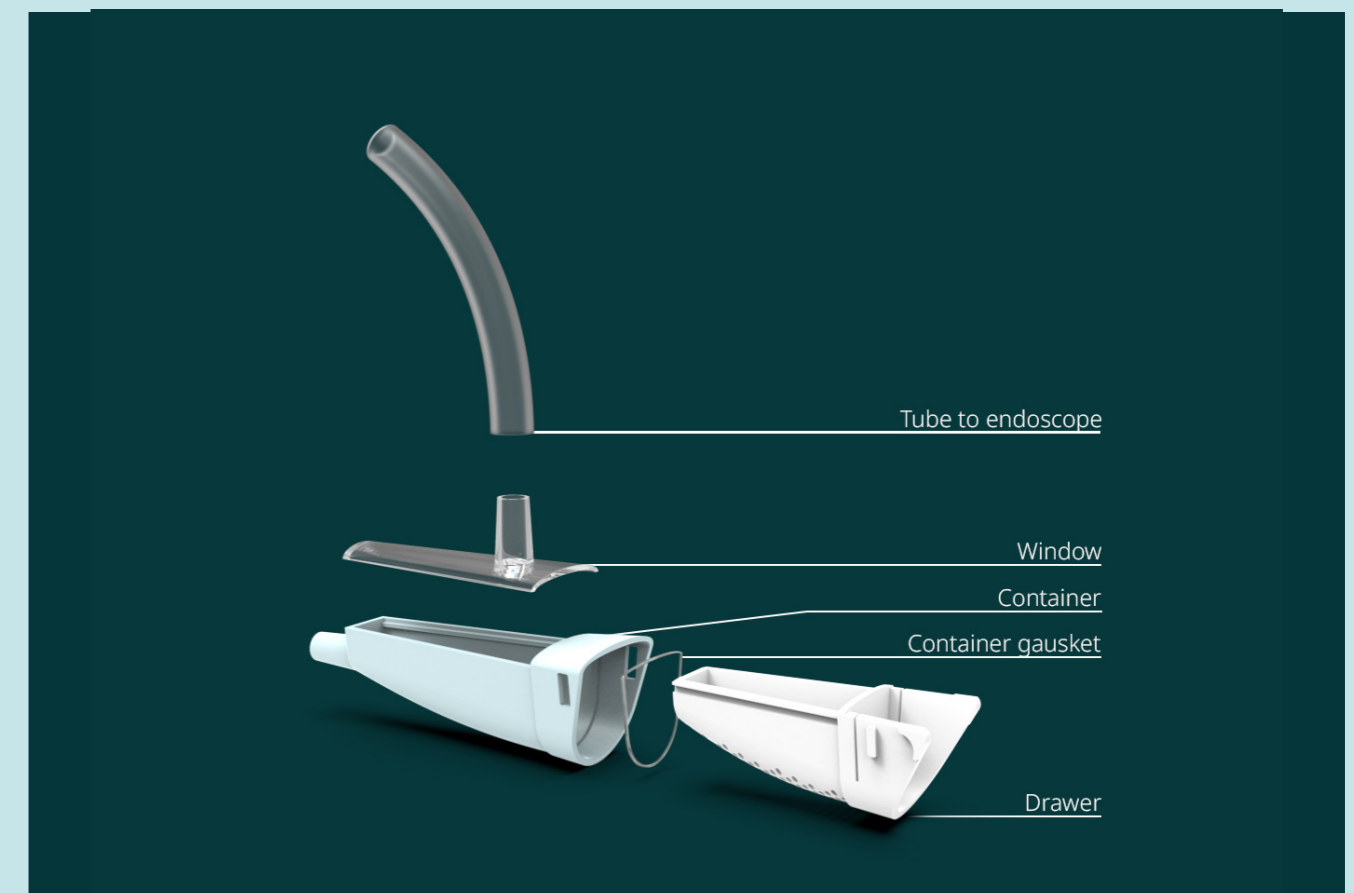

Figure 7.1.2: Components of rethink concept.



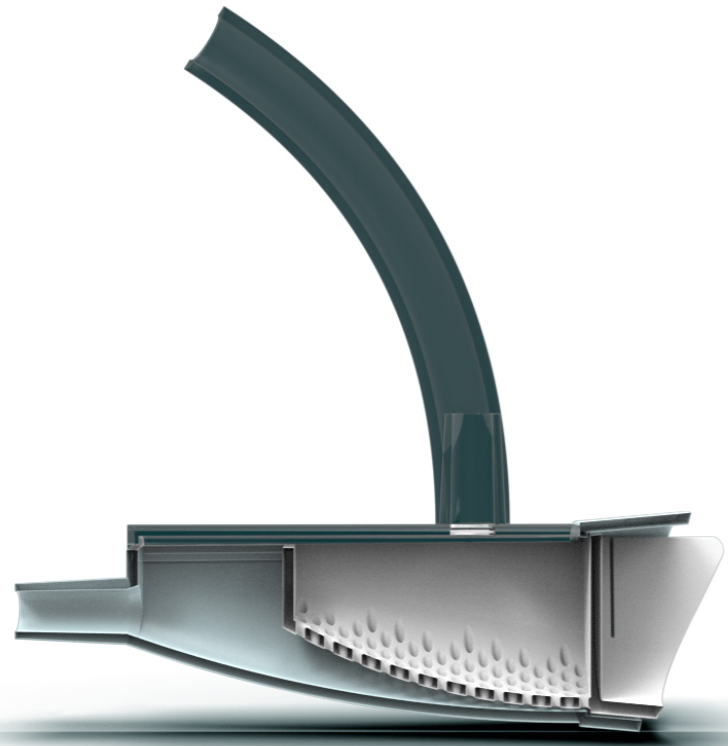

Figure 7.1.5: Section view of the rethink concept.

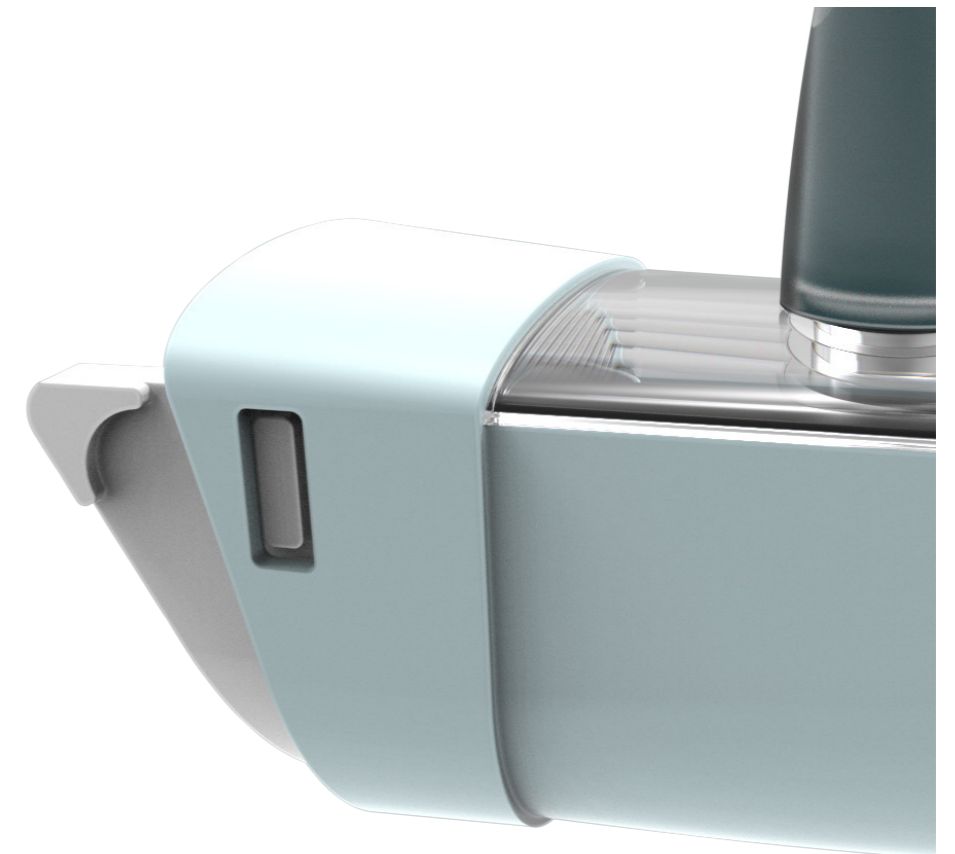

Figure 7.1.6: Click mechanism that connects drawer to the container.



Figure 7.1.4: Rethink concept connected to endoscope.



7.1.7: Size of redesign concept.



Figure 7.1.8: Drawer of polyp trap concept.

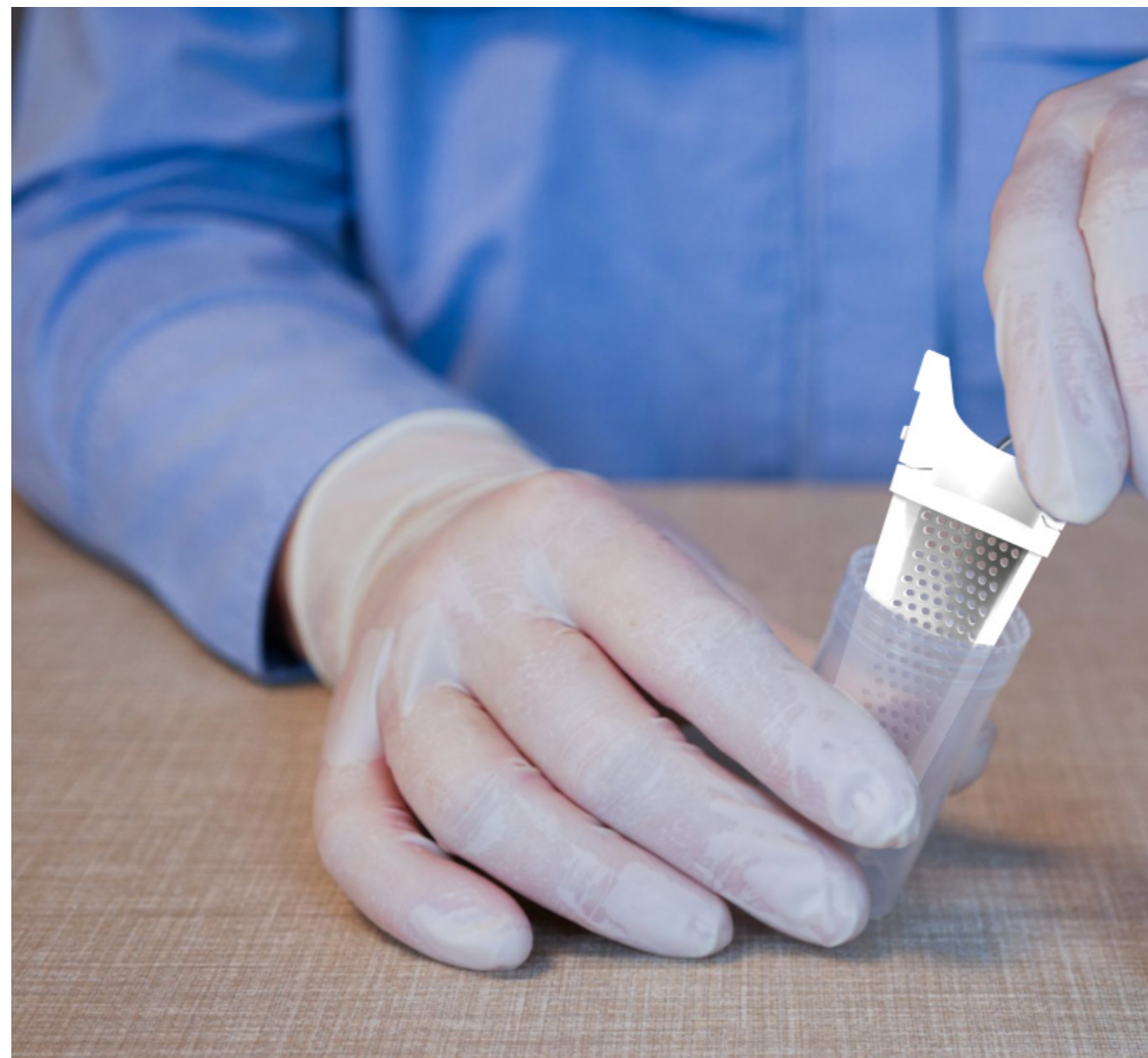

Figure 7.1.10: Nurse releases polyp into formalin cup.

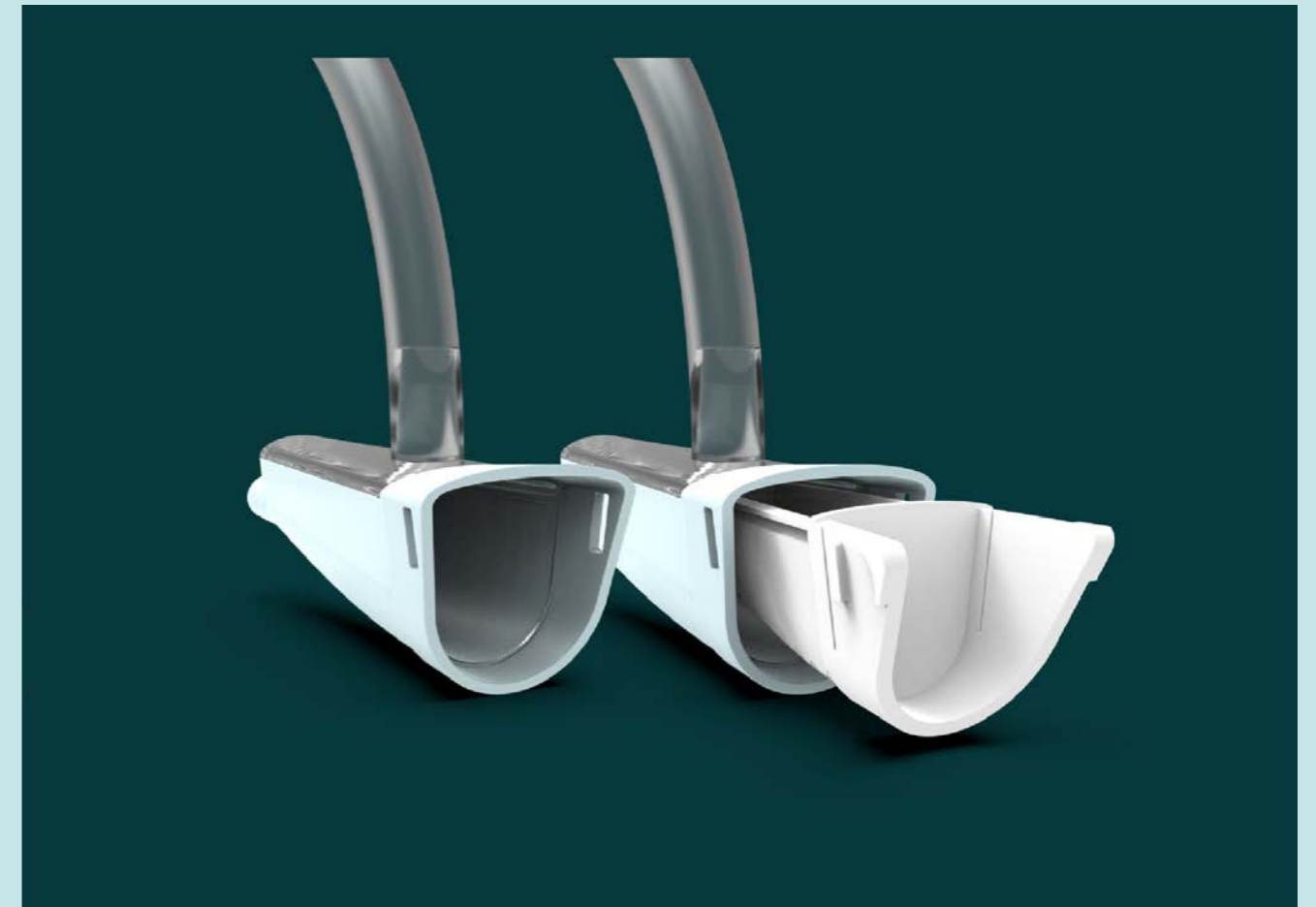

Figure 7.1.9: Drawer sliding into the container.

The polyp trap has a separate window rather than an entire transparent body (see figure 7.1.11). This enables the nurse to inspect the polyp, yet limits the required amount of high-impact material required. The window

and container are connected through plastic welding. A deliberate fault line is implemented to cause the two components to fall apart when shredded.

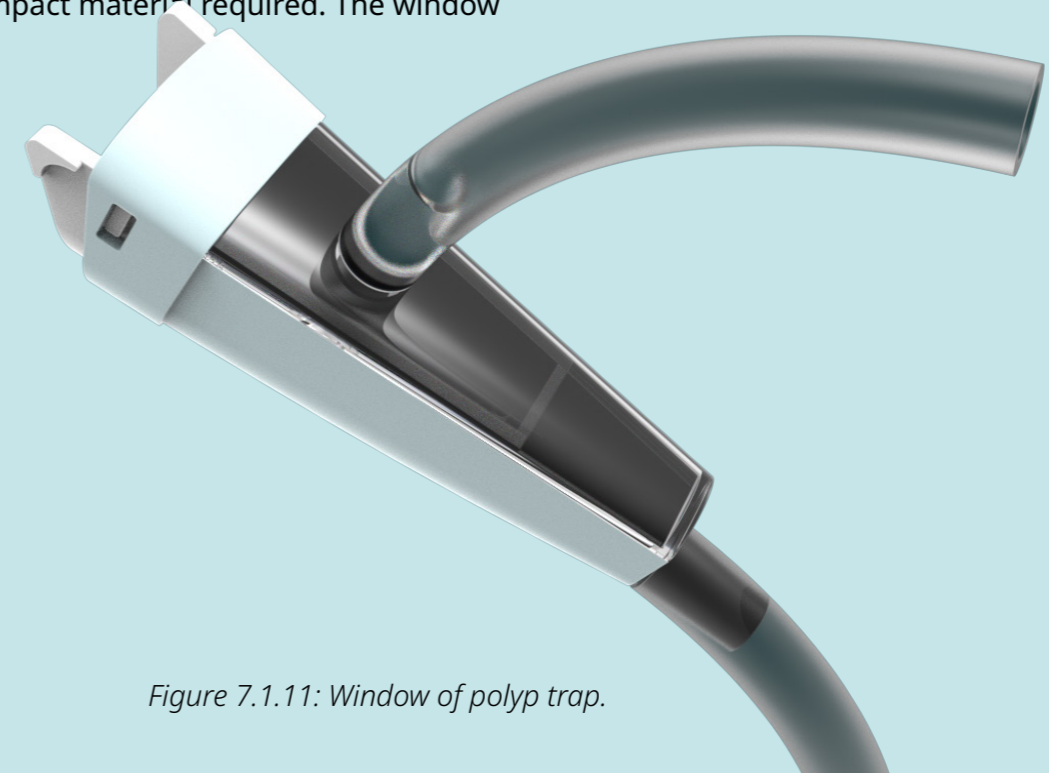

Figure 7.1.11: Window of polyp trap.



### Reuse concept

The reuse concept is similar in design to the rethink concept, except for the addition of the lid (see figure 7.1.12), and its exchangeable window (see figure 7.1.13). The window can easily be (dis)connected with a click mechanism (see figure 7.1.14). A gasket nestled into the container makes the connection air and watertight.

### Materials

For the rethink concept, a combination of either SAN for the window and PE for the container and drawer, or AS and PHA was selected. The environmental impact and cost price of each material should be considered, before selecting a specific set of materials. As the end of life of the polyp trap currently is incineration, taking material separation into account is unnecessary. However, in case this changes, a fault line is placed on the edge of the connection between the window and

container, to create a breaking point where the materials should separate when the polyp trap is shredded.

As the possible implementation of the reusable concept would be further away in the future, it is more of a vision and a concept product, compared to the more concrete rethink concept. Therefore, it is to be expected, that more research will be performed on the optical qualities of PHA, as of now, it can be transparent, but the optical qualities are unknown. Therefore, this material is selected for the container, its drawers, lid and window. If this concept is ever to be implemented, the use of PHA for the window should be re-evaluated.

As the focus for the redesign was on the components with the highest CF, the relatively less impactful components remained the same material.

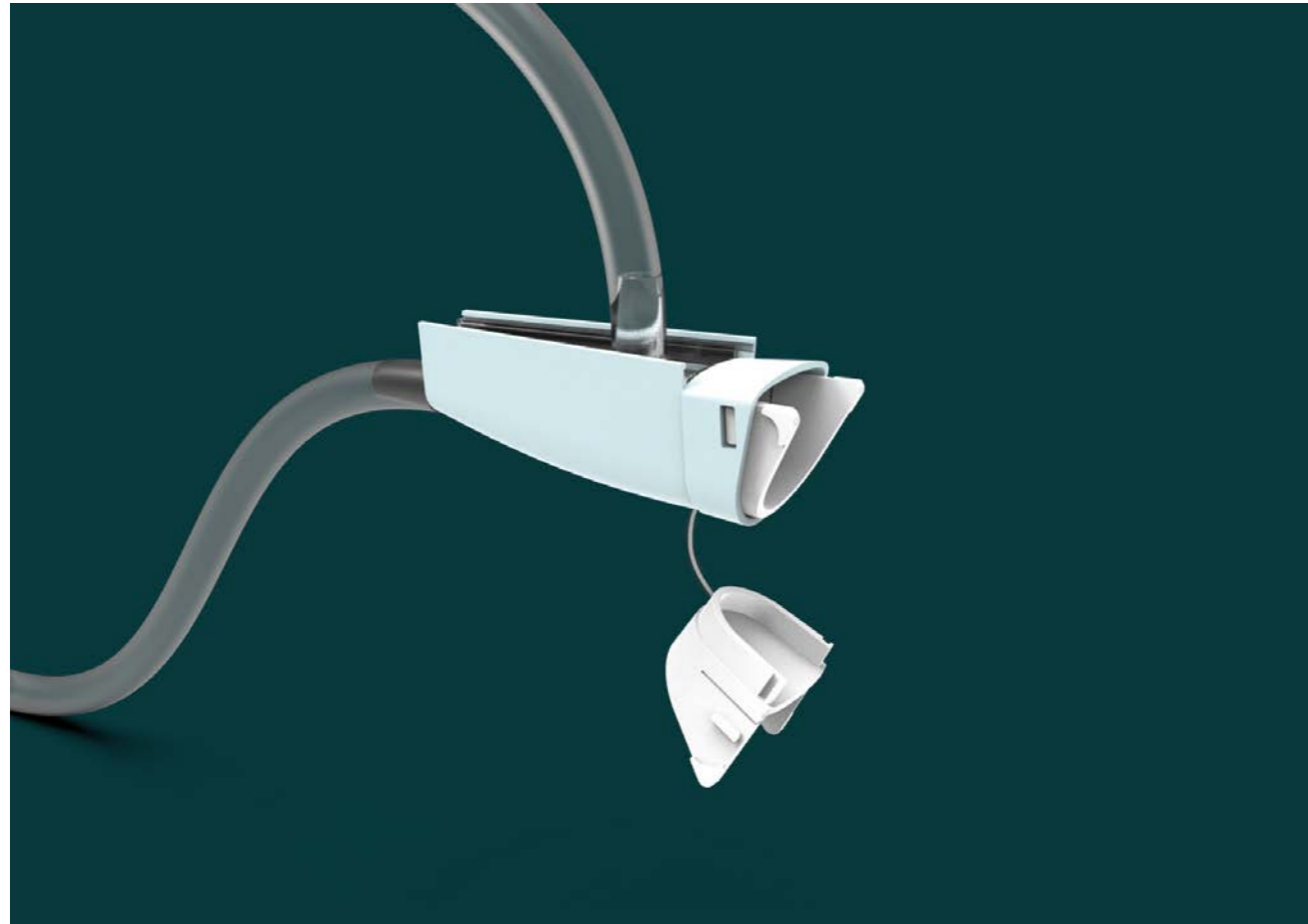

Figure 7.1.12: Reuse concept.



Figure 7.1.14: click mechanism of the window.

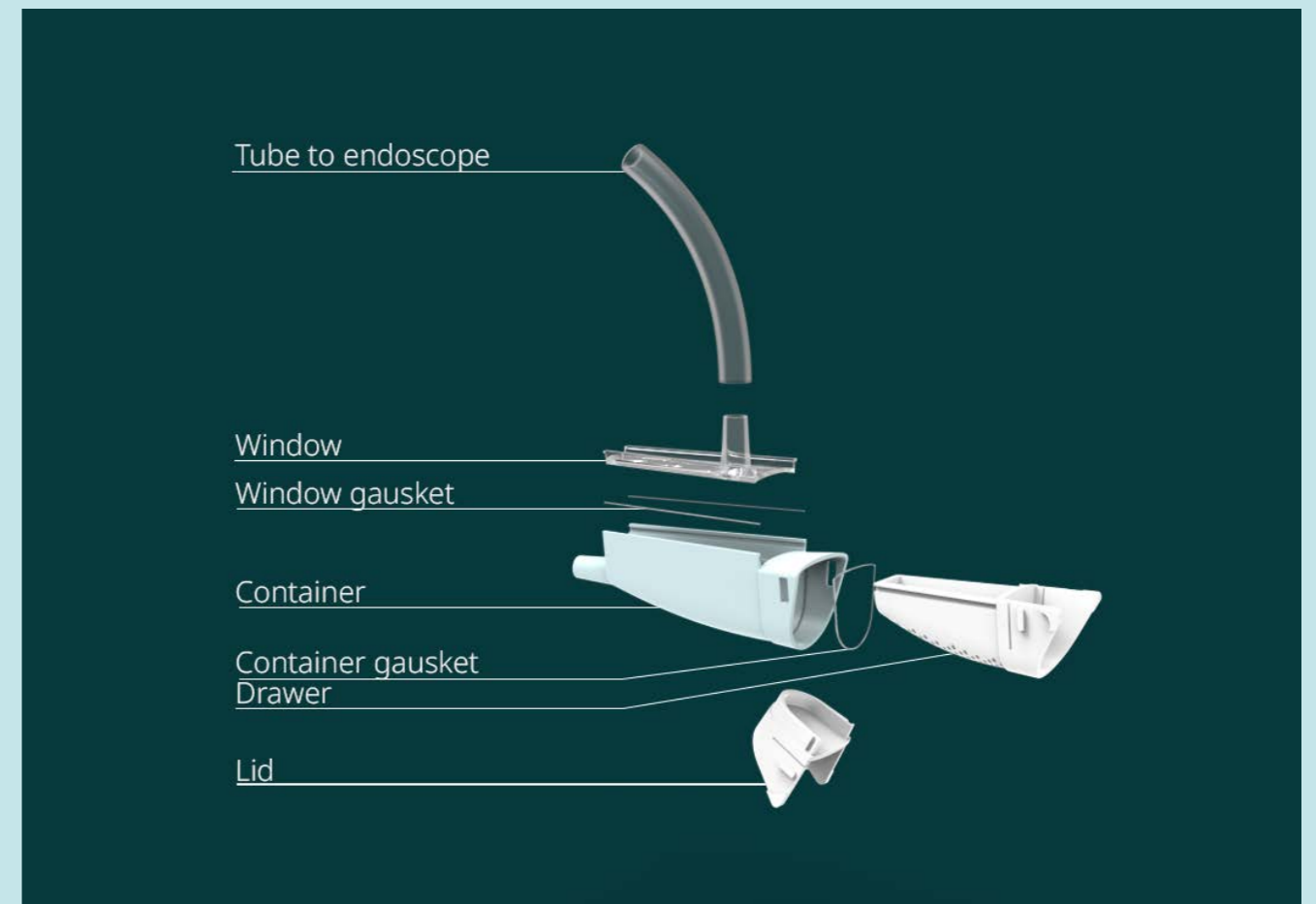

Figure 7.1.13: Components of reuse concept.

## 7.2 Product use

In the reuse concept, several components of the polyp trap are re-used, throughout the day, whereas other components are used per patient. This decreases the amount of components required per day, thus lowering the polyp traps waste production and CF (see

figure 7.2.1). The reuse concept changes the way the polyp trap is used. These changes and their implications of the working process are visualised in figure 7.2.2. With reuse, several risks occur. These risks are further explained in figure 7.2.3.

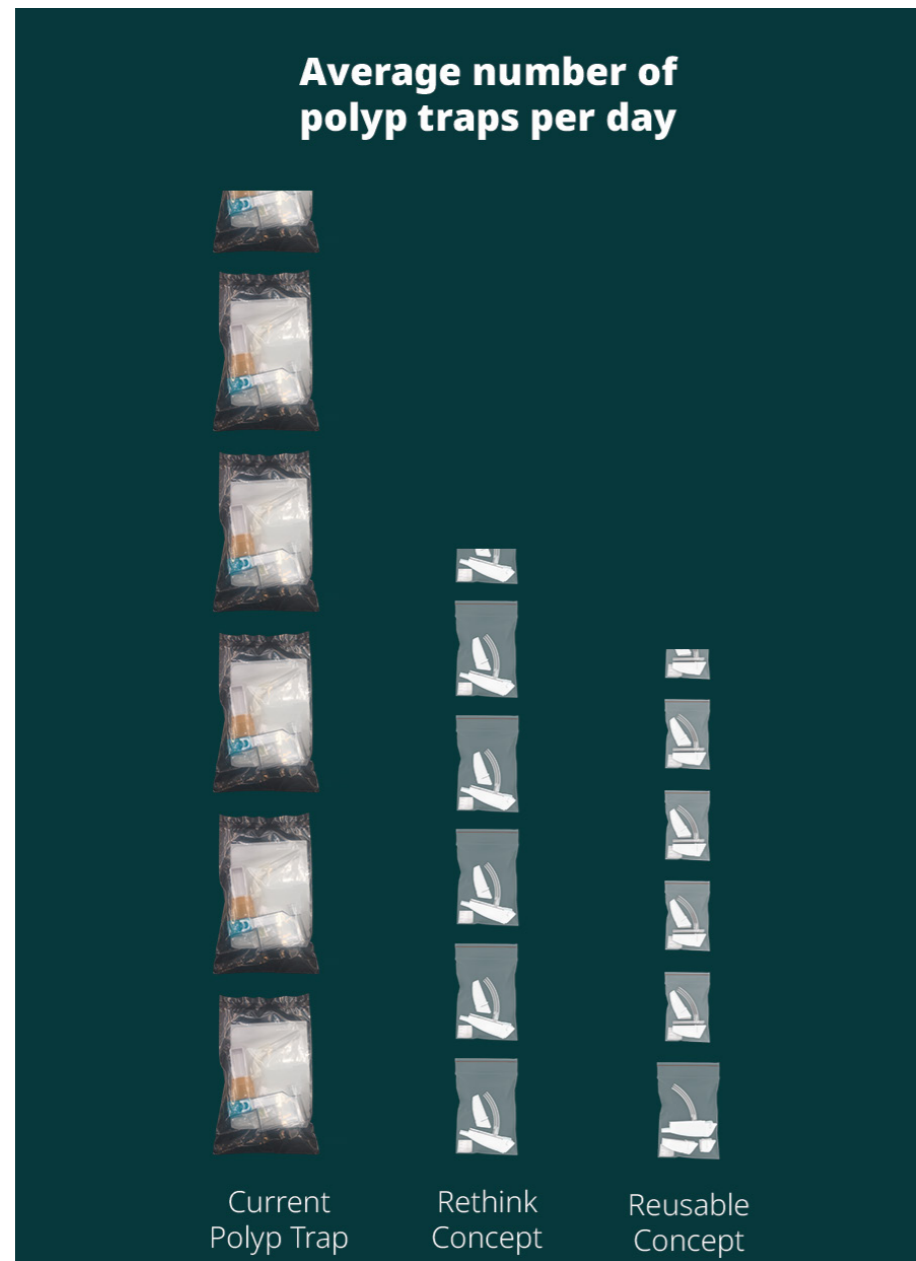

Figure 7.2.1: Daily use of the current polyp trap compared to the rethink and reuse concept.

## Reuse Scenario

### First Polypectomy



The nurse takes the supplementary kit from the packaging.



The nurse connects the polyp trap to the endoscope.

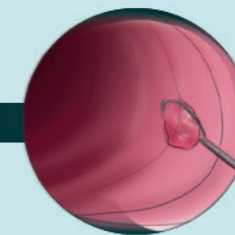

The doctor removes the polyp.

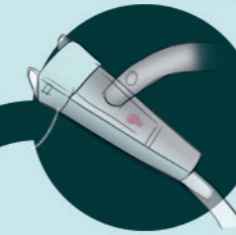

The nurse checks the polyp trap if the polyp has entered the trap.

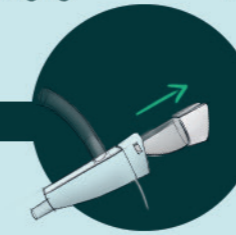

The nurse removes the drawer.

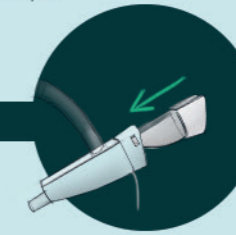

The nurse replaces the drawer.



The nurse stores the polyp in a formalin cup.

### After Endoscopy

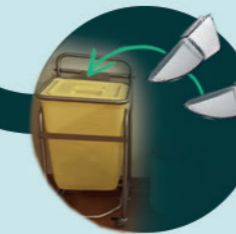

The nurse disposes of drawers.

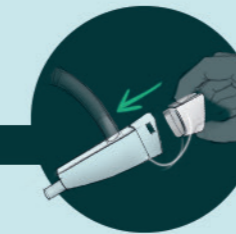

The nurse places the lid on the trap.



The endoscope is flushed.



The nurse cleans the outside of the polyp trap.

### Before next Polypectomy



The polyp trap is ready for the next polypectomy.

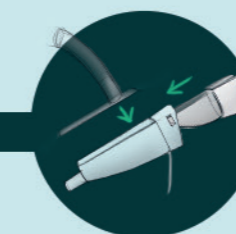

The nurse replaces the window and the drawer.

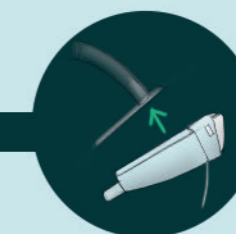

The nurse removes the window.



The nurse takes the supplementary kit from the packaging.

### End of day



The nurse disposes of the entire polyp trap.

Figure 7.2.2: User journey of the reuse concept.



# Risks associated with reuse



Risks	Description	Probability	Consequences	Mitigation action	Description
<p>Spread of infections</p> 	<p>As the nurse touches the endoscope insertion tube as well as the polyp trap during a polypectomy, pathogens could stick to its surface, and the product could become a source of infections in the endoscopy suite.</p>	<p><b>High</b> As the nurse touches the insertion tube, the polyp, and the patient, diseases carried by pathogens originating from the polyp trap could easily be transferred from patient to patient.</p>	<p><b>Severe</b> The consequences of the spread of infections due to unsanitary endoscopy would be severe, especially taking into account the risk of antibiotic-resistant bacteria in a hospital.</p>		<p>The risk can easily be mitigated by cleaning the surface of the polyp trap between endoscopies, as is already part of the protocol for other contaminated surfaces in the endoscopy suite.</p>
<p>Polyp tissue contamination</p> 	<p>A risk of polyp sample contamination could occur if the nurse forgets to replace the window. In this case, the old window could contain polyp tissue from the previous patient and contaminate the current patient's sample.</p>	<p><b>Medium</b> As protocols are generally followed strictly, such a mistake could be prevented by making it a part of the nurses' protocol, and therefore their routine. However, mistakes can be made, and to accurately estimate the risk of this happening, further user research is required.</p>	<p><b>Severe</b> A contaminated polyp tissue sample could lead to false results, which could lead to grave consequences for the patient. Receiving a false positive result could lead to unnecessary treatment, and emotional harm, whereas receiving a false negative result could lead to delayed or even no treatment. This could cause a treatable disease to become more severe, and could even negatively impact a patient's chances of recovery.</p>		<p>The risk can easily be mitigated, by providing the window and new drawers in a single package. If the nurse initially forgot to remove the old window, opening the package and seeing the new window might cause them to remember. However, how well this reminding mechanism would work should be analysed through user tests.</p>
	<p>A risk of polyp sample contamination could take place, if tissue from the previous patient were to stick in the container, and travel to the new drawer during the next polypectomy.</p>	<p><b>Low</b> As there is a constant airflow from the endoscope to the irrigation system, the probability of tissue moving against this airstream is very low.</p>	<p><b>Low</b> As there is a constant airflow from the endoscope to the irrigation system, the probability of tissue moving against this airstream is very low.</p>		<p>The airflow through the polyp trap will likely already mitigate this risk. However, this should be analysed through clinical tests if the product would be implemented.</p>

Figure 7.2.3: Visualisation of risks associated with the reuse concept.

## 7.3 Fast-track LCA of Concepts

To compare the concepts to the current polyp trap, and to each other, a fast-track LCA is performed. Figure 7.3.1 and 7.3.2 show that both waste generation and carbon footprint for each concept is significantly lower.

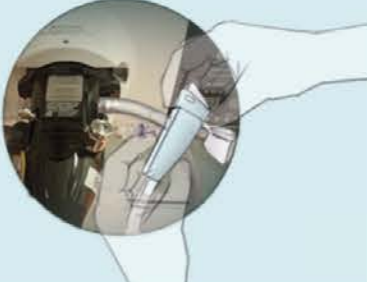
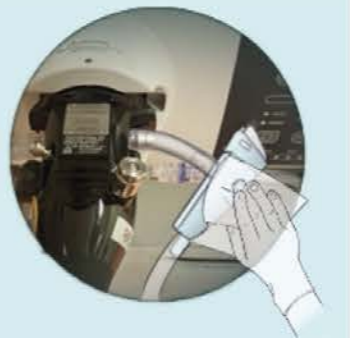
Noteworthy is that the waste generation of the reusable concept is only slightly lower than that of the rethink concept variation (see figure 7.3.1). Its CF is even higher than that of both rethink concept variations. This could be caused by the need for an additional component, the lid, and the fact that this component design has not been optimised for minimal material use. Another factor contributing to the relatively high CF of the reuse concept could be the tube. The tube has a relatively high CF but also

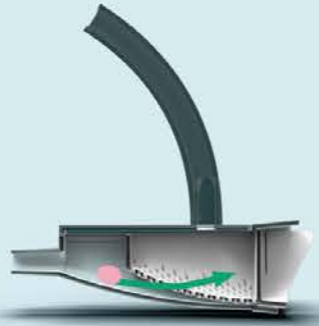
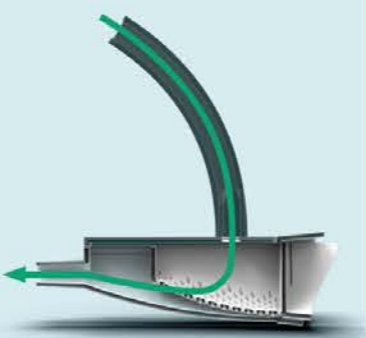
needs to be replaced for each patient to prevent tissue contamination. Therefore, this part significantly increases the CF of the supplementary kit of the reuse concept.

Figure 7.3.2 shows that the CF of the bio-based variation of the rethink prototype is somewhat higher compared to that of the fossil-based variation. However, taking into account the fault bars and the fact that CF data about bio-based and bio-degradable materials is currently not very exact, this difference is negligible. Therefore, if the cost price of the bio-based variation is acceptable it should be preferred over the fossil-based variation, as it reduces material extraction as well as the CF. Therefore, the bio-based variation is the more circular option.

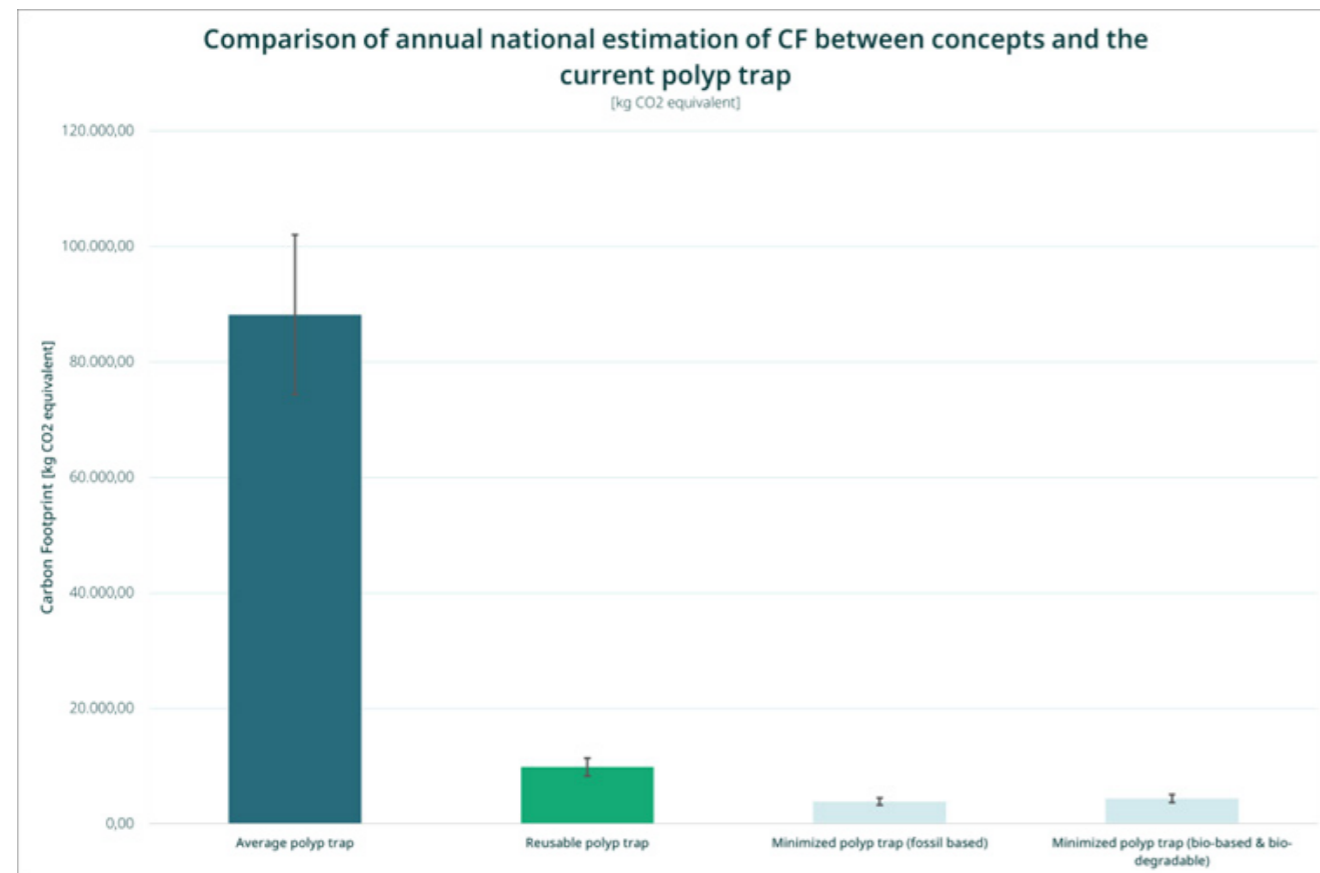

Figure 7.3.2: Estimation of annual CF in the Netherlands between various concepts and the current polyp trap.

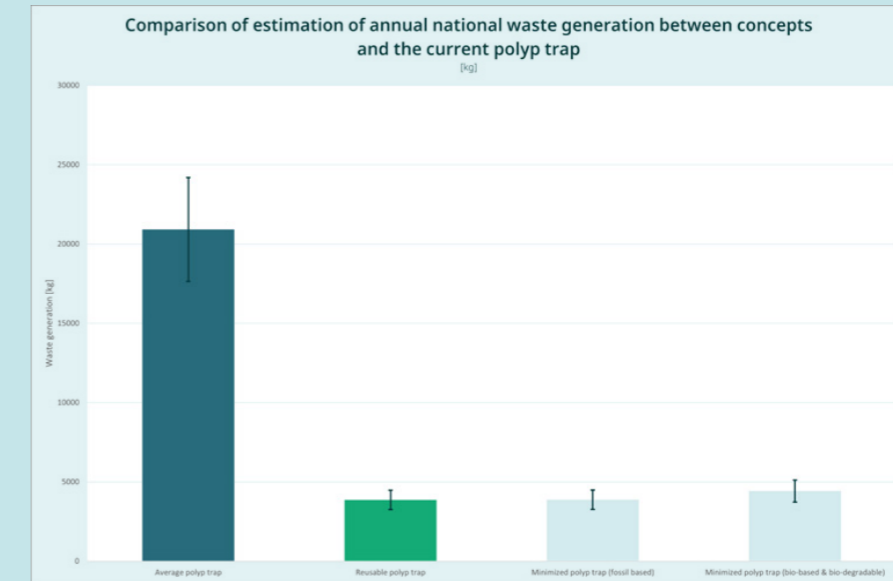

Figure 7.3.1: Estimation of annual waste generation in the Netherlands between various concepts and the current polyp trap.

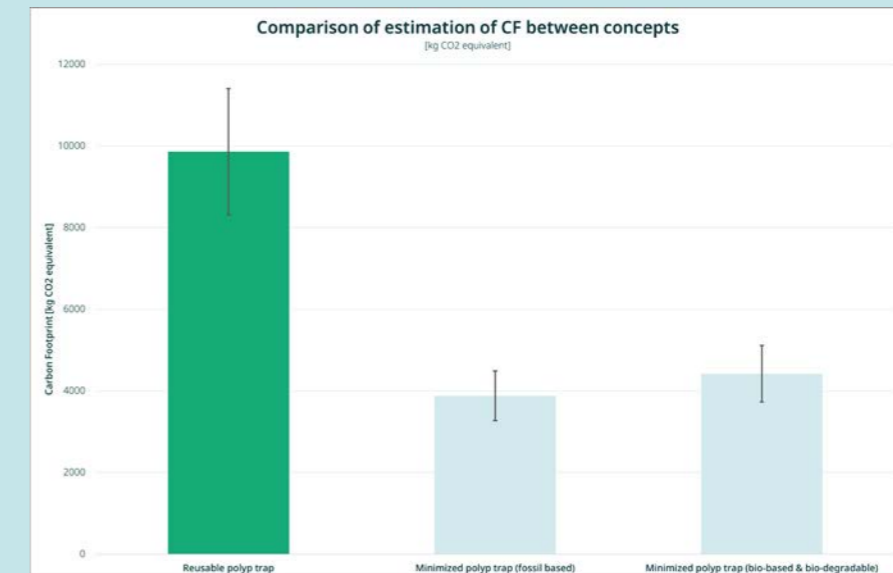

Figure 7.3.3: Estimation of annual CF in the Netherlands between concepts.

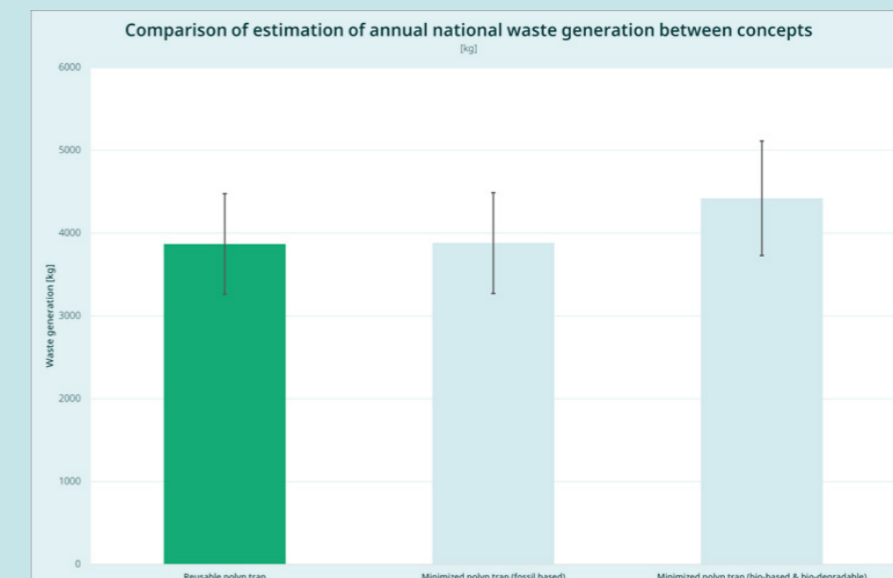

Figure 7.3.4: Estimation of annual waste generation in the Netherlands between concepts.



## 7.4 Cost price

The cost price of the concept is built up of manufacturing costs, the costs of purchased parts, such as the packaging and the tube, and transportation costs. To somewhat simplify the calculation, transportation costs are neglected. However, a 20% margin is added to the total cost price of the product to take into account neglected and unforeseen costs. In figure 7.4.1, the cost price per polypectomy of the fossil-based and bio-based rethink concepts is compared to that of the rethink concept (see appendix H for cost price calculations).

### Manufacturing costs

The manufacturing costs for the concepts consist of the material costs and moulding costs. For simplification, the assembly costs have been neglected. To account for this, and the transport costs, a margin of 20% is added to the total cost price.

### Material costs

The cost price is calculated for the reuse concept, and the fossil-based and bio-based rethink concept, described previously in this chapter. The price per kg of Styrene Acrylonitrile (SAN), polyethylene (HDPE), polyurethane (PU) and Polyhydroxyalkanoates (PHA) were respectively determined at €2,13/kg (Business analytiq, 2023; Chemanalyst, 2023c; Intratec, 2018), €1,16/kg (Chemanalyst, 2023a; PlasticPortal.eu, 2019; Statista Research Department, 2023), €2,5/kg (Chemanalyst, 2023b) and €3,95/kg (Crutchik et al., 2020) respectively. When a product is injection moulded, a small amount of material is wasted due to plastic solidifying in the channel through which the plastic flows. This is called a sprue. Therefore, a margin of 10% has been added to the required amount of material to account for the sprues. For the Fossil-based rethink concept, this leads to a material cost of €0,025. For the fossil-/bio-based rethink concept, the material cost is €0,092. The material costs for the total reuse concept, are €0,18. The material costs for the base kit and supplementary kit are

respectively €0,12 and €0,064

### Moulding costs

According to (REX Plastics, 2013), a relatively small single cavity injection mould costs between about €900 and €4.600. An average injection mould for relatively small simple parts costs about €11.000 (REX Plastics, 2013). Assuming that the gaskets could use a very simple mould, the costs are determined to be €900. The mould costs somewhat more complex container, drawer and lid have been set at €11.000. As the window is smaller, it should be somewhere between €900 and €4.600. Therefore, the window mould costs are determined to be €8.000. When comparing this to a cost price estimation (personal communication H&P Moulding, 2023) for the PHA-based minimized polyp trap, tooling and processing cost per part come down to €0,10.

For the Fossil-based rethink concept, this leads to a manufacturing cost of €1,18. For the fossil-/bio-based rethink concept, the manufacturing cost is €1,25. The manufacturing costs for the total reuse concept, are €. The manufacturing costs for the base kit and supplementary kit are relatively high, due to the limited amount of containers used per year, which increases the mould price per component.

How the manufacturing costs are reflected in the cost price of the product, depends on the number of expected sales, and the desired return on investment. For this calculation, the assumption is that a significant will be replaced by the new product. This number is set at about 47.500 polyp traps annually (personal communication Meditec, 2023). The expected rate of investment is set at two years, which leads to the cost price for the mould being divided over 95.000 products. Apart from manufactured parts, the concepts also contain several purchased parts: the tube, the packaging bag and a label. The costs

of these purchased parts are determined at €0,24 (Flexibeleslangen.nl, n.d.; Rubber Magazijn, n.d.; Rubberfabriek, n.d.); €0,019 (Brada, n.d.; De Verpakkings Winkel, n.d.; Eurofolie, n.d.) and €0,11 (PIXArtPrinting, n.d.; RS, n.d.; Uniek Etiket, n.d.) respectively. The total cost of this set of purchased parts is €0,38.

### Revenue

If the concepts would be sold at comparable

prices to the current polyp trap, which is between €6-10 (personal communication Meditec, 2023), the annual revenue of the fossil-based and fossil / bio-based polyp traps would be about €293.000 and €289.000. For the total reuse concept, annual revenue would be about €294.000 (see figure 7.4.2). As the revenue gained with the bio-based rethink concept is only slightly lower compared to the fossil-based variation, this material combination should be selected for implementation into the concept.



Figure 7.4.1: Cost price per polypectomy of rethink (fossil- and bio-based variation) and reuse concept.

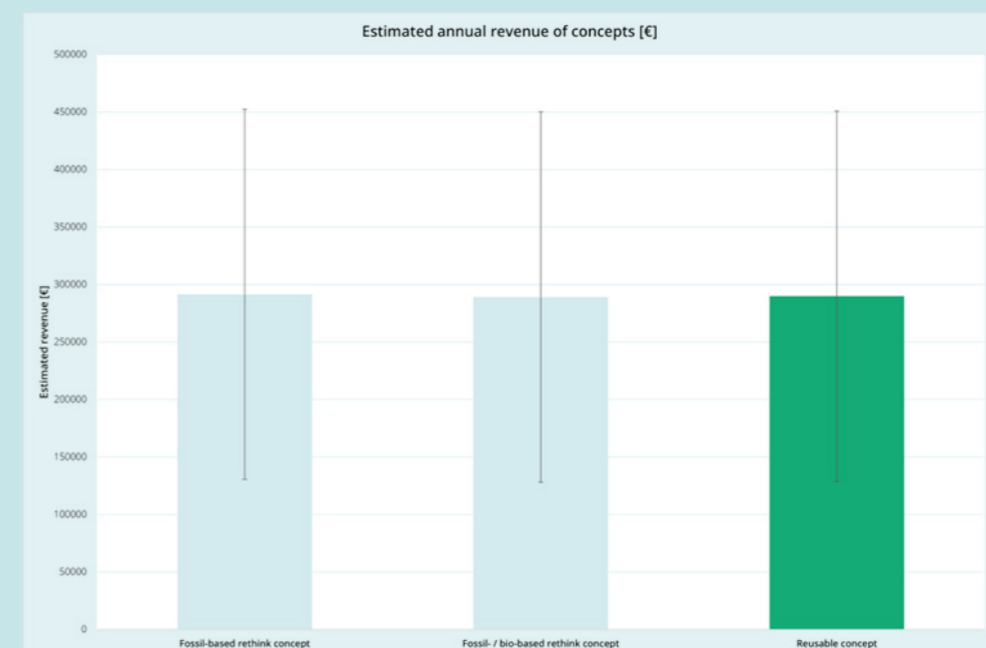

Figure 7.4.2: Estimation of annual revenue of the concepts, based on a retail price between €6 and €10.

## 7.5: Discussion

### Detailing

Some refinement is still required for the design of the rethink concept. Although some prototypes have been made to test the closing mechanism of the concept drawers, this mechanism has not been tested for usability, or air or water tightness. Therefore, it might not meet the requirements for those aspects yet. Another aspect of the rethink concept that needs to be further developed, is the fault lines. As the window and container are welded together, this is a case of a monstrous hybrid. Currently, this is not a problem, as all hospital-specific waste is incinerated. However, if recycling or composting technology for HSW is implemented on a larger scale at some point, the two material must separate upon shredding. Otherwise, the product might end up contaminating the waste stream.

The reusable polyp trap is in essence more of a conceptual model compared to the rethink model. Therefore, it requires more detailing to be feasible. The connection of the window is still somewhat crude and needs to be worked out and tested both in water and air tightness and in usability.

### Reuse

Interviews with nurses showed that they were generally very motivated to contribute to a more sustainable endoscopy suite. This motivation might in part stem from the large amount of SUD and packaging material they have to dispose of daily. This is also the reason that they preferred the reusable concept over the current polyp trap. However, this answer was based on a scenario on paper. Testing the concept in real life, with prototypes, could lead to different results, as the additional amount of tasks, the useability of the concept, or the efficiency of use might prove to be disappointing.

Additionally, there is no clear answer yet on if the reusable concept could be implemented, and how realistic the risk of polyp tissue

decontamination is. Although this risk is small, due to the constant airflow through the product, the effects of the possibility of tissue contamination are too severe to permit even a small risk.

### Environmental impact

There are some aspects of the polyp trap that could have been further optimized to decrease its environmental impact. The tube connecting the endoscope to the polyp trap is a component with a relatively high CF for which opportunities for alternative materials, redesign or material reduction have not been extensively explored yet. However, it does have a significant impact on the polyp traps CF and is one of the reasons that the reusable polyp trap has a relatively higher CF compared to the rethink concept. Additionally, alternative packaging materials have not been explored yet, as they have a relatively low impact on the polyp traps CF. However, they still contribute, and it could be an opportunity to investigate lower-impact materials. Additionally, the packaging of medical SUD could, depending on the specific hospital and its waste processing partner, possibly be recycled. Similarly, an alternative gasket material could be explored. This is also a component with a relatively low CF, which is why it was not the focus of the search for more sustainable materials. It could also be interesting to determine whether this component could be made from a bio-degradable material, as this could result in a completely biodegradable reusable polyp trap.

As mentioned earlier in this rapport, the main environmental impact of the polyp trap can be defined as material extraction and CO2 emissions. Both concepts reduce material extraction, through using a bio-based material. Additionally, its CO2 footprint is greatly decreased due to reducing the amount of (high impact) material, and through partly re-using the product. Overall, both concepts have successfully managed to reduce the environmental impact of the

polyp trap. However, even if the impact of waste generation is decreased due to decreased waste generation, both concepts are still SUD. Therefore, even if they are more sustainable than the current polyp trap, they are not circular, or carbon neutral. For an SUD such as the polyp trap to be completely

circular, circular end-of-life strategies need to be implemented. These strategies are currently not available due to the regulation of hospital specific waste, and the need for research and technological development in the sterilisation of medical waste and fermentation of bio-based plastics.

## 7.6 Conclusion & Recommendations

Although interviews suggest that the reusable polyp trap might be a desirable and feasible product, usability tests need to be performed with nurses and doctors, to properly analyse its working principle and efficiency in real life. Additionally, more input from infection prevention specialists is required to gain insight into the probability of the risk of tissue contamination, and infection risk due to the continuous use of the container throughout the day. If the reuse concept were to be implemented, the risk of tissue contamination should be tested clinically beforehand.

Additionally, the usability and air tightness of the drawer to container connection should be refined and tested, for both the rethink and the redesign concept. For the reuse concept, the design of the lid and the window should be further detailed, also taking into account usability and air tightness.

The Environmental impact of the poly trap could be decreased by implementing each of the concepts, as they have a lowered impact on material extraction and a decreased CF compared to the current

polyp trap. However, if any or both of the concepts are to be further developed, new research and technical advancement in the field of fermenting biodegradable plastics in the context of HSW and disinfection and recycling of HSW should be taken into account. A medical SUD can only be truly circular if there is a circular end-of-life option. Therefore, if any opportunity for a circular end-of-life occurs, the design of the polyp trap should be adapted to that specific strategy.

To lower the environmental impact even further, the concepts should be further detailed, with a focus on minimizing the required amount. Furthermore, alternative materials for the tube, gaskets and packaging could still be explored.



## 8.1 Reflection

The aspect I found most challenging in this project, is the lack of data surrounding medical SUD. This made it difficult to grasp the scale of the problem and define a scope. Especially as the polyp trap is just one of many SUD used in the endoscopy department. There are many other SUD used in the endoscopy suite that are more complex, such as snares, or more frequently used, such as the formalin cup. Then there are many different protocols in different hospitals, that determine how long an SUD can be used and through which waste stream they could be disposed of. This all makes the term SUD and its impact somewhat elusive, and at times caused me to lose track of the scope of the project and get lost in details. However, I did learn a lot about the complexity of the medical context in general, as well as that of the medical SUD, its use, risks, protocols and regulations and finally the challenges that occur when redesigning them more sustainably.

I was very impressed by the awareness of the problems of the nurses I encountered during my observational research and interviews. Part of this awareness seemed to stem from the amount of SUD they need to dispose of on a daily basis. This makes the excessive use of SUD a very visible problem for staff who come into direct contact with them. The interventions initiated by green teams in hospitals could be quite inspiring, and I think that these initiatives could have a significant impact on the environmental footprint of hospitals, especially if insights and data are shared.

## 8.2 Acknowledgements

I would like to thank my supervisors Jan-Carel and Puck for their involvement in my project, and valuable feedback, insights and ideas. Thanks to Anne and Paulien from Windesheim, I managed to visit various hospitals and speak to different healthcare professionals, as well as receive feedback and ideas about how to approach this project. Furthermore, I would like to thank Allard and Louis from Meditec for their expertise about the polyp trap specifically, and the field of SUD in general and Bart of H&P moulding for his expertise in manufacturing, and experience in implementing a novel material such as PHA. Lastly, I would like to thank the other students who worked within Windesheim's research group for their valuable ideas and input.

# References



# 9. References

- Achterberg, E., Hinfelaar, J., & Bocken, N. (2016). Master circular business with the value hill. <https://hetgroenebrein.nl/wp-content/uploads/2017/08/finance-white-paper-20160923.pdf>
- Bakker, C., & Balkenende, R. (2021). A renewed recognition of the materiality of design in a circular economy: The case of bio-based plastics. In *Materials Experience 2: Expanding Territories of Materials and Design* (pp. 193–206). Elsevier. <https://doi.org/10.1016/B978-0-12-819244-3.00020-X>
- Beilenhoff, U., Biering, H., Blum, R., Brljak, J., Cimbri, M., Dumonceau, J. M., Hassan, C., Jung, M., Kampf, B., Neumann, C., Pietsch, M., Pineau, L., Ponchon, T., Rejchrt, S., Rey, J. F., Schmidt, V., Tillett, J., & Van Hooft, J. E. (2018). Reprocessing of flexible endoscopes and endoscopic accessories used in gastrointestinal endoscopy: Position Statement of the European Society of Gastrointestinal Endoscopy (ESGE) and European Society of Gastroenterology Nurses and Associates (ESGENA) - Update 2018. *Endoscopy*, 50(12), 1205–1234. <https://doi.org/10.1055/a-0759-1629>
- Bhatia, V., Bhardwaj, V., & Tevethia, H. V. (2021). Reprocessing and Reuse of Endoscopic Accessories. *Journal of Digestive Endoscopy*, 12(04), 214–220. <https://doi.org/10.1055/s-0041-1741077>
- Bishop, G., Styles, D., & Lens, P. N. L. (2021). Environmental performance comparison of bioplastics and petrochemical plastics: A review of life cycle assessment (LCA) methodological decisions. In *Resources, Conservation and Recycling* (Vol. 168). Elsevier B.V. <https://doi.org/10.1016/j.resconrec.2021.105451>
- Brada. (n.d.). LDPE poly bag 20my transparant format 14/ 2 x 4 x 26 cm. Retrieved August 22, 2023, from <https://www.bradaverpakkingen.nl/en/ldpe-flat-bag-20my-transparant-format-14-2-x-4-x-2.html>
- Business analytiq. (2023, August). Styrene acrylonitrile resin (SAN) price index. <https://businessanalytiq.com/procurementanalytics/index/styrene-acrylonitrile-resin-san-price-index/>
- Celitron. (2023, February 26). Medical waste autoclaves: turning hazardous to harmless! How steam sterilizers are revolutionizing healthcare waste disposal. <https://celitron.com/en/blog/medical-waste-autoclaves-turning-hazardous-to-harmless#:~:text=A%20medical%20waste%20autoclave%20is,the%20waste%20safe%20for%20disposal.>
- Centrum Gezondheid en Maatschappij, R. voor V. en M. (2023, February 2). Ziekenhuiszorg | Aanbod | Instellingen. [https://www.vzinfo.nl/ziekenhuiszorg/aanbod/instellingen#:~:text=Nederland%20telt%2069%20ziekenhuisorganisaties,en%20kinderziekenhuizen\)%20en%20147%20buitenpoliklinieken](https://www.vzinfo.nl/ziekenhuiszorg/aanbod/instellingen#:~:text=Nederland%20telt%2069%20ziekenhuisorganisaties,en%20kinderziekenhuizen)%20en%20147%20buitenpoliklinieken)
- Chemanalyst. (2023a, June). High Density Polyethylene (HDPE) Price Trend and Forecast. <https://www.chemanalyst.com/Pricing-data/hdpe-7>
- Chemanalyst. (2023b, June). Polyurethane (PU) resin Price Trend and Forecast. <https://www.chemanalyst.com/Pricing-data/polyurethane-pu-resin-1150>
- Chemanalyst. (2023c, June). Styrene Acrylonitrile (SAN) Price Trend and Forecast. <https://www.plasticportal.eu/en/cenove-reporty?year=2019&week=26>
- Commissie voor Volksgezondheid, W. en S. (VWS). (2018). VERORDENING (EU) 2017/746 VAN HET EUROPEES PARLEMENT EN DE RAAD - van 5 april 2017 - betreffende medische hulpmiddelen voor in-vitrodiagnostiek en tot intrekking van Richtlijn 98/ 79/ EG en Besluit 2010/ 227/ EU van de Commissie. [https://www.eerstekamer.nl/eu/documenteu/2017/746\\_verordening\\_betreffende/f=vkxlera1orfl.pdf](https://www.eerstekamer.nl/eu/documenteu/2017/746_verordening_betreffende/f=vkxlera1orfl.pdf)
- Crutchik, D., Franchi, O., Caminos, L., Jeison, D., Belmonte, M., Pedrouso, A., Val del Rio, A., Mosquera-Corral, A., & Campos, J. L. (2020). Polyhydroxyalkanoates (PHAs) production: A feasible economic option for the treatment of sewage sludge in municipal wastewater treatment plants? *Water (Switzerland)*, 12(4). <https://doi.org/10.3390/W12041118>
- Daikin Global. (n.d.). Flexible endoscopes. Retrieved August 19, 2023, from <https://www.daikinchemicals.com/solutions/industries/life-sciences/flexible-endoscopes.html>
- De Verpakkingen Winkel. (n.d.). Bag, Rib-seal bag, LDPE, 15x20cm, 50my, transparent. Retrieved August 22, 2023, from [https://www.deverpakkingwinkel.com/en\\_US/p/bag-rib-seal-bag-ldpe-15x20cm-50my-transparent/310/](https://www.deverpakkingwinkel.com/en_US/p/bag-rib-seal-bag-ldpe-15x20cm-50my-transparent/310/)
- Ellen Macarthur Foundation. (n.d.). The technical cycle of the butterfly diagram. <https://ellenmacarthurfoundation.org/articles/the-technical-cycle-of-the-butterfly-diagram>
- Elta, G. H., & Law, R. J. (2020). Great haste makes great waste: Do available data support the widespread adoption of disposable endoscopes? In *Gastrointestinal Endoscopy* (Vol. 91, Issue 2, pp. 404–405). Mosby Inc. <https://doi.org/10.1016/j.gie.2019.10.005>
- Eurofolie. (n.d.). Zak ldpe transparant los 160 x 240 mm - 40 my. Retrieved August 22, 2023, from <https://eurofolie.nl/Zak-ldpe-transparant-los-160-x-240-mm-40-my/1201009>
- Flexibeleslangen.nl. (n.d.). Brevosil ZI transparante siliconen slang (4 tot en met 8 mm inwendig). Retrieved August 22, 2023, from <https://www.flexibeleslangen.nl/brevosil-zi-transparant-4-tot-en-met-8-mm-inwendig/>
- Globe Scientific. (n.d.). Formalin Containers & Safety Products. Retrieved May 16, 2023, from <https://www.globescientific.com/gs-products/formalin-containers-safety-products.html>
- HCL Technologies. (2013). An Overview of the Plastic Material Selection Process for Medical Devices.
- Hossain, M. S., Balakrishnan, V., Rahman, N. N. A., Sarker, M. Z. I., & Kadir, M. O. A. (2012). Treatment of clinical solid waste using a steam autoclave as a possible alternative technology to incineration. *International Journal of Environmental Research and Public Health*, 9(3), 855–867. <https://doi.org/10.3390/ijerph9030855>
- Integraal Kankercentrum Nederland. (2021). Monitor-darmkanker-2021-definitieve-versie. Intratec. (2018, August). Styrene Acrylonitrile Resin Price | Current and Forecast. <https://www.intratec.us/chemical-markets/styrene-acrylonitrile-resin-price>
- Joseph, B., James, J., Kalarikkal, N., & Thomas, S. (2021). Recycling of medical plastics. *Advanced Industrial and Engineering Polymer Research*, 4(3), 199–208. <https://doi.org/10.1016/J.AIEPR.2021.06.003>
- Kane, G. M., Bakker, C. A., & Balkenende, A. R. (2018). Towards design strategies for circular medical products. *Resources, Conservation and Recycling*, 135, 38–47. <https://doi.org/10.1016/j.resconrec.2017.07.030>
- Maurice, J. B., Siau, K., Sebastian, S., Ahuja, N., Wesley, E., Stableforth, W., & Hayee, B. (2020). Green endoscopy: a call for sustainability in the midst of COVID-19. *The Lancet Global Health*, 8(7), e901–e908. [https://doi.org/10.1016/S2214-109X\(20\)30229-1](https://doi.org/10.1016/S2214-109X(20)30229-1)
- McKeen, L. (2012). Introduction to Food Irradiation and Medical Sterilization. In *The Effect of Sterilization on Plastics and Elastomers* (pp. 1–40). Elsevier. <https://doi.org/10.1016/b978-1-4557-2598-4.00001-0>
- Molenveld, K., Post, W., Ferreira, S. F., De Sévaux, G., & Hartstra, M. (2022). Paving the way for biobased materials: a roadmap for the market introduction of PHA's. <https://doi.org/10.18174/561676>
- Nippon. (2013, August 20). Olympus Endoscopes: The Inside Story. [https://www.nippon.com/en/features/c00513/Olympus\\_\(8272\).OFP-2\\_Endoscopic\\_Flushing\\_Pump\\_and\\_Accessories.](https://www.nippon.com/en/features/c00513/Olympus_(8272).OFP-2_Endoscopic_Flushing_Pump_and_Accessories.) <https://mdc.olympus.eu/>

# Appendix



# A. Project brief

## Personal Project Brief - IDE Master Graduation

Reducing the environmental impact of single-use plastics in endoscopies. project title

Please state the title of your graduation project (above) and the start date and end date (below). Keep the title compact and simple. Do not use abbreviations. The remainder of this document allows you to define and clarify your graduation project.

start date 02 - 03 - 2023 04 - 08 - 2023 end date

### INTRODUCTION \*\*

Please describe, the context of your project, and address the main stakeholders (interests) within this context in a concise yet complete manner. Who are involved, what do they value and how do they currently operate within the given context? What are the main opportunities and limitations you are currently aware of (cultural- and social norms, resources (time, money,...), technology, ...).

The health carbon footprint in the Netherlands is the highest in the world relative to the percentage of its national carbon footprint (see figure 1). When comparing the carbon footprint per capita, the Dutch healthcare sector is within the 6<sup>th</sup> highest emitters of carbon dioxide (Pichler et al., 2019). Although there have not been any complete life cycle analysis of endoscopies in Dutch hospitals, single use plastics are recognised to be a substantial problem in the Dutch healthcare system (Bijlsma, 2020).

A research group at Hogeschool Windesheim has initiated the project "Weggoeien? ons een zorg!" With the goal of exploring which innovations in products, processes, information technology and business models could contribute to a more circular healthcare system in the Netherlands. The research group is working together with multiple hospitals, and several companies specialised in medical products providing cases that several students from Hogeschool Windesheim and other universities will be working on. The company that I will work together with, is Meditec. Meditec is a supplier of single use medical products, mainly specialised in endoscopic supplies. They are in the process of becoming a producing company as well as a supplier, producing their own products locally rather than sourcing products from China. They recognise the need to move to a more sustainable healthcare system, and would like to explore how they can adapt their envisioned products to be more sustainable.

Within the healthcare setting, endoscopies are considered to be a large contributor to the carbon footprint. It is estimated to be the third largest waste generator, and amounts to a carbon footprint of about 85,768 metric tons of CO2 emissions annually in the USA alone (Siau et al., 2021).

The large carbon footprint of endoscopies is caused by multiple factors, such as the large number of operations (high caseload), energy intensive decontamination processes and a heavy reliance on single-use plastic instruments and consumables. Most of these disposables are not recyclable and will thus be incinerated (Siau et al., 2021). Furthermore, companies producing and supplying endoscopic devices and products are still moving away from multi-use devices and towards single use devices (De Melo et al., 2021). Therefore, the amount of waste generated by endoscopic surgeries is still growing. One of the single-use plastic products that is used during endoscopies, is the polyp trap (see figure 2). Polyp traps, or polyp retrieval traps, are used collect polyps during endoscopic surgeries. They are connected to a device that uses suction to collect removed polyps, and enable medical professionals to separately contain polyps, that can be analysed in the lab. In figure 3, the factors contributing to the carbon footprint of endoscopies, and their relation to single use products is visualised.

Opportunities for redesigning single-use products such as the polyp trap, could be in redesigning the product and its packaging at a concept level, rethinking its functionality, and the way it is used. To redesign the polyp trap as a sustainable product, it's current environmental impact needs to be determined. From there, different circular strategies such as re-use, recycling, bio-materials can be considered and more sustainable alternatives can be developed.

Bijlsma, J. (2020a, January 14). 'Waarom wachten op een overheidsverbod op plastic?' - Zorgvisie. *Zorgvisie*. Retrieved February 20, 2023, from <https://www.zorgvisie.nl/waarom-wachten-op-een-overheidsverbod-op-plastic/>  
De Melo, S. W., Taylor, G. L., & Kao, J. Y. (2021). Packaging and Waste in the Endoscopy Suite. *Techniques and Innovations in Gastrointestinal Endoscopy*, 23(4), 371–375. <https://doi.org/10.1016/j.tige.2021.07.004>  
Pichler, P., Jaccard, I. S., Weisz, U., & Weisz, H. (2019). International comparison of health care carbon footprints. *Environmental Research Letters*, 14(6), 064004. <https://doi.org/10.1088/1748-9326/ab19e1>  
Siau, K., Hayee, B., & Gayam, S. (2021). Endoscopy's Current Carbon Footprint. *Techniques and Innovations in Gastrointestinal Endoscopy*, 23(4), 344–352. <https://doi.org/10.1016/j.tige.2021.06.005>

space available for images / figures on next page

## Personal Project Brief - IDE Master Graduation

introduction (continued): space for images

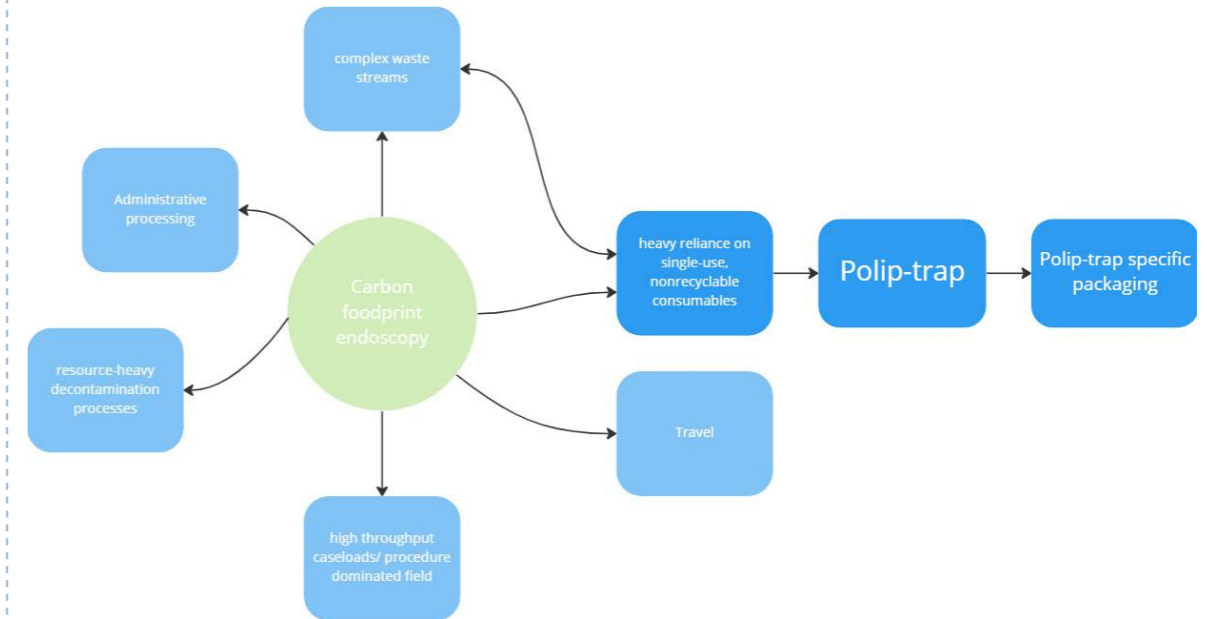

image / figure 1: Visualisation of causality of the carbon footprint of endoscopies, and relation to single use products.



image / figure 2: A polyp trap.

**PROBLEM DEFINITION \*\***

Limit and define the scope and solution space of your project to one that is manageable within one Master Graduation Project of 30 EC (= 20 full time weeks or 100 working days) and clearly indicate what issue(s) should be addressed in this project.

The research group at Hogeschool Windesheim together with the company Meditec is exploring innovations in products, processes, information technology and business models that could contribute to a more circular healthcare system in the Netherlands. Endoscopies have one of the largest carbon footprints, and are one of the greatest sources of waste within the healthcare system. One factor that is greatly contributing to this, is the large amount of disposable medical instruments and single-use plastic products that are used during endoscopic surgeries. As the reliance on single use products in the context of endoscopies is still growing, the carbon footprint of endoscopic surgeries will presumably only grow over the coming years. As there is a lack of knowledge of the impact of single-use plastics on the carbon footprint of endoscopy, this is an interesting topic for exploration. To come to a concrete design challenge, I will focus on one of these disposable plastic products; The polyp trap. Furthermore, a redesign of this product could lead to concrete concept, that could be implemented by Meditec. Therefore, the problem definition is the following: The use of disposable plastic products, such as the polyp trap, in endoscopic surgeries are fundamentally linear and co

The use of disposable plastic products, such as the polyp trap, in endoscopic surgeries are fundamentally linear and contributes to its large carbon footprint and waste production. To design a more sustainable alternative, the product and its use needs to be reconsidered at a fundamental level, and different circular strategies need to be considered.

**ASSIGNMENT \*\***

State in 2 or 3 sentences what you are going to research, design, create and / or generate, that will solve (part of) the issue(s) pointed out in "problem definition". Then illustrate this assignment by indicating what kind of solution you expect and / or aim to deliver, for instance: a product, a product-service combination, a strategy illustrated through product or product-service combination ideas, ... . In case of a Specialisation and/or Annotation, make sure the assignment reflects this/these.

I am going to research the impact of the consumption of single use plastic products in endoscopic surgery, and how this can be decreased, using the polip trap as a case study. I will analyse the current context and use of this product, and reconsider it's use, lifecycle and material. This will result in a design of a sustainable polip trap, and insight in how the consumption of single-use products in the healthcare sector can be decreased through design interventions.

In this graduation project, I will use the polyp trap as a case study, analysing the use of the polyp trap throughout its whole lifecycle. As a first step, I will analyse the polyp trap as a product, and its current use and impact. Secondly, I will zoom out, and research different possibilities that could decrease the use of single use plastics: Re-use, Bio-based and bio degradable plastics, and recycling. Within these possibilities, I will determine what is possible, what is feasible, and what is allowed (rules & regulations). As a next step, I will analyse the use of the polyp trap throughout its lifecycle in different hospitals, to map the use of this disposable product, and explore possibilities to rethink the product on a concept level. Furthermore, I would like to interview healthcare professionals that interact with this product and procedure, to validate findings of the lifecycle analysis, and gather their insights about which parts of this process could be altered. These insights, combined with the findings of my literature research, analysis of the polyp trap, will lead to a redesign of the polyp trap. This redesign will be created through ideation and creative sessions with a focus group of healthcare professionals. As a last step, I will evaluate the redesign through user tests, to evaluate the usability, feasibility and viability and compare the envisioned lifecycle of the new polyp trap with the lifecycle of the current polyp trap.  
Possible end results of this re-design could be: A different concept that replaces the polyp trap, making it obsolete, or combining it with other product functionalities used in endoscopic surgeries; A redesign of the polyp trap that enables it to be sterilised and reused or recycled; A redesign of the polyp trap specifically tailored to reduce its weight, or use to use bio-based or bio-degradable materials.

**PLANNING AND APPROACH \*\***

Include a Gantt Chart (replace the example below - more examples can be found in Manual 2) that shows the different phases of your project, deliverables you have in mind, meetings, and how you plan to spend your time. Please note that all activities should fit within the given net time of 30 EC = 20 full time weeks or 100 working days, and your planning should include a kick-off meeting, mid-term meeting, green light meeting and graduation ceremony. Illustrate your Gantt Chart by, for instance, explaining your approach, and please indicate periods of part-time activities and/or periods of not spending time on your graduation project, if any, for instance because of holidays or parallel activities.

start date 2 - 3 - 2023 end date 4 - 8 - 2023

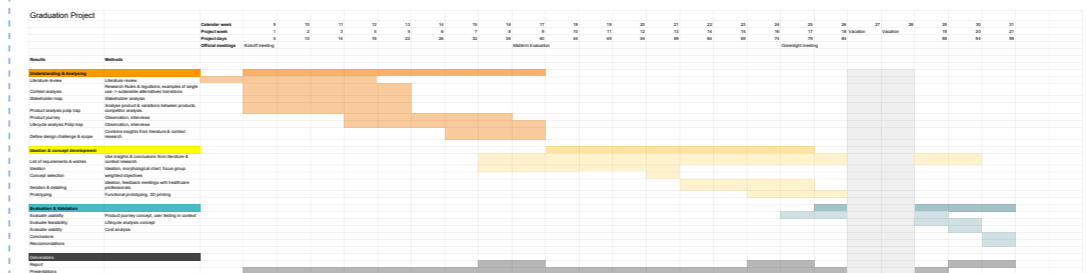

My envisioned graduation project exists of three phases. During phase 1: Understanding & Analysing, I will conduct literature and context research into the current impact of single use products in endoscopic surgery and the impact of the polyp trap specifically. I will analyse the product as it is now, its use and its context, and the stakeholders in this context through observations in hospitals and interviews. From these insight, I will create a product journey and a determine the current environmental impact. Furthermore, I will research different circular strategies. I will end this phase with a design challenge definition and vision, and a start of a list of requirements. In the second phase: Ideation & concept development, I will first create a list of requirements. Secondly, I will create ideas through ideation and ideation methods such as morphological charts. These ideas will be a starting point for creative sessions with focus groups of medical professionals. The new ideas will be input a second round of ideation, that will lead the development of two to three concepts. One of these concepts will be chosen for further development and will be iterated on and detailed with the input of medical professionals through feedback meetings. The end results of this phase are a detailed concept of a re-design of the polyp trap, including a prototype. In the last phase: Evaluation & Validation, I will evaluate the developed concepts desirability the development of a product through user testing in context, and feedback meetings with medical professionals. The Feasibility and viability of the product will be evaluated through the development of a product and user journey, and feedback meetings with medical professionals. Furthermore, a life-cycle analysis will be performed on the envisioned product, and compared to the current product. Lastly, a cost price analysis will be made.  
I plan to graduate in 21 weeks, as I plan to follow a 3 EC elective course in Q3. I have planned a two-week holiday in week 27-28. I plan to meet with my mentors every two weeks, and with the research group at Hogeschool Windesheim every two weeks, of which at least one out of two meetings offline.



### MOTIVATION AND PERSONAL AMBITIONS

Explain why you set up this project, what competences you want to prove and learn. For example: acquired competences from your MSc programme, the elective semester, extra-curricular activities (etc.) and point out the competences you have yet developed. Optionally, describe which personal learning ambitions you explicitly want to address in this project, on top of the learning objectives of the Graduation Project, such as: in depth knowledge a on specific subject, broadening your competences or experimenting with a specific tool and/or methodology, ... . Stick to no more than five ambitions.

I am following the Medisign specialisation, as I think there are many interesting design challenges in this field. Mainly because products designed for this field can have a very direct impact on peoples lifes, as they may depend on, be supported or hindered by their medical devices. However, our healthcare system in the Netherlands is already quite advanced, and this also comes with negative effects on the environment. There is an interestion tension between the drive to further develop our medical field, and the need to make this field a lot more sustainable. I think this will be one of the largest challenges worldwide within the context of moving to a sustainable future, and would like to work on this in my future career as a designer. Therefore, I would like to learn more about designing sustainable medical products.

I have worked together with hospitals and medical professionals before, during the elective Medical Device Prototyping (BioMechanical Engineering course) where I designed a product to improve sanitation of robotic instruments. I would like to use the experience I gained working in this context, to effectively plan interviews and observations and use aquired insights as a starting point for the (re)design of a product.

During my master thesis, I would like deeper understanding of the challenges of moving to a more sustainable future that come with a complexe context such as the healthcare system. I would like to learn more about how to use design interventions to tackle these challenges. An important part of that is rules & regulations. During my electives I followed the course rules & regulations for designing medical devices. During my graduation project I would like to learn more on this topic, especially concerning design for sustainability.

Lastly, I would like to use a co-design approach during the Ideation & concept development phase of my master thesis. I have already worked with variations of co-design in projects during courses such as ACD, and JMP, and would like to gain experience with this methodology.

### FINAL COMMENTS

In case your project brief needs final comments, please add any information you think is relevant.

# B. Planning

## Graduation planning & Activities

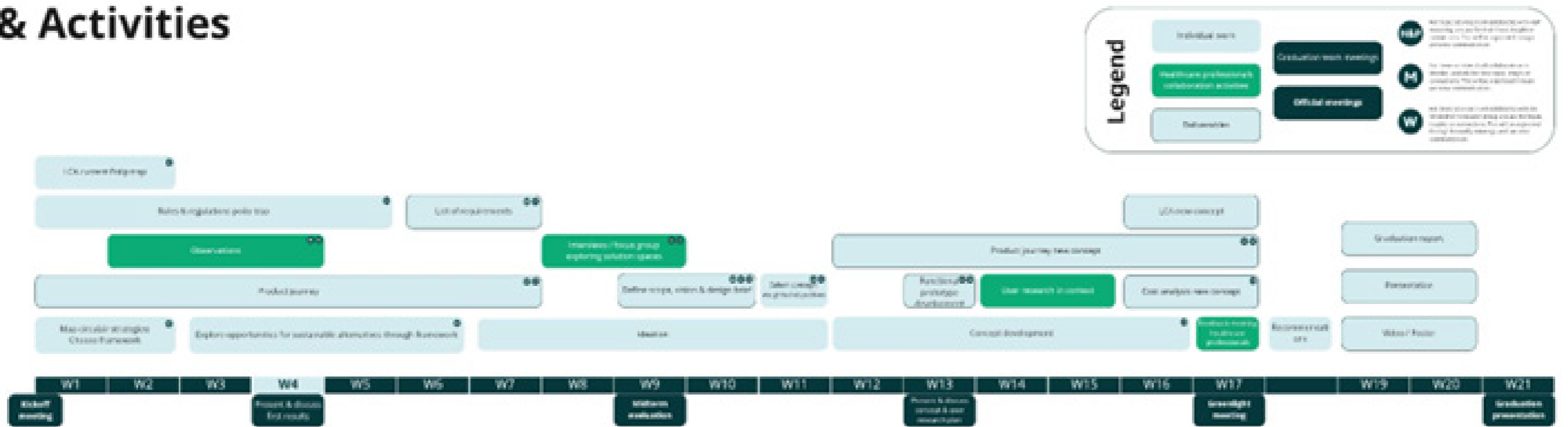



# C. Consent form

## C.1 Consent form 1: Observational research

You are being invited to participate in a research study that is part of a master thesis for titled: Reducing the environmental impact of single-use plastics in endoscopy. The research study is part of a master thesis for the master Integrated Product Design at the TU Delft. This study is being done by Meike Bloem from the TU Delft, in collaboration with the research group "Weggoeien? Ons een zorg!" at hogeschool Windesheim, and the companies H&P moulding and Meditec. The responsible researcher for this research is Dr. ir. J.C. Diehl.

The purpose of the observational research is to gain insight into the use of plastic SUD and explore opportunities for alternative solutions. These insights will be used in the graduation report, which will be published at the TUDelft Repository. I will be asking you to answer questions regarding the use of the polyp trap, and other products that are used during endoscopy, the process of an endoscopy and/or sustainable strategies regarding medical products in general.

As with any online activity the risk of a breach is always possible. To the best of our ability your answers in this study will remain confidential. We will minimize any risks by saving data on a password protected server, and deleting all non-anonymous data, when the graduation project has finished. Anonymous data will be saved within the research group "Weggoeien? Ons een zorg!" at Windesheim, until the end of this project, in 2026. This data will only be available to researchers in the research group.

Your participation in this study is entirely voluntary and you can withdraw at any time. You are free to omit any questions.

Contact details:

Corresponding researcher:  
Meike Bloem  
m.bloem-2@student.tudelft.nl

Responsible researcher TU Delft:  
Prof. Dr. Ir. Diehl  
J.C.Diehl@tudelft.nl

## C.2 Consent form 2: Interviews

You are being invited to participate in a research study that is part of a master thesis for titled: Reducing the environmental impact of single-use plastics in endoscopy. The research study is part of a master thesis for the master Integrated Product Design at the TU Delft. This study is being done by Meike Bloem from the TU Delft, in collaboration with the research group "Weggoeien? Ons een zorg!" at hogeschool Windesheim, and the companies H&P moulding and Meditec. The responsible researcher for this research is Dr. ir. J.C. Diehl.

The purpose of the interview is to gain insight in the use of plastic SUD, and explore opportunities for alternative solutions. These insights will be used in the graduation report, which will be published at the TUDelft Repository. I will be asking you to answer questions regarding the use of the polyp trap, and other products that are used during endoscopy, the process of an endoscopy and/or sustainable strategies regarding medical products in general. With your consent, I will record this interview, with the purpose of making a transcript. If you prefer the meeting not to be recorded, this will be respected and no recording will be made.

As with any online activity the risk of a breach is always possible. To the best of our ability your answers in this study will remain confidential. We will minimize any risks by saving data on a password protected server, and deleting all non-anonymous data, including interview recordings, when the graduation project has finished. Anonymous data will be saved within the research group "Weggoeien? Ons een zorg!" at Windesheim, until the end of this project, in 2026. This data will only be available to researchers in the research group.

Your participation in this study is entirely voluntary and you can withdraw at any time. You are free to omit any questions.

Contact details:

Corresponding researcher:  
Meike Bloem  
m.bloem-2@student.tudelft.nl

Responsible researcher TU Delft:  
Prof. Dr. Ir. Diehl  
J.C.Diehl@tudelft.nl

## D. Metadata observations & interviews

ID	Hospital, company, sector	Function
P1	Isala Zwolle	Nurse endoscopic departement
P2	Isala Zwolle	Nurse endoscopic departement
P3	Isala Zwolle	Nurse endoscopic departement
P4	Isala Zwolle	Sterilisation employee endoscopic department
P5	Groene Hart ziekenhuis	Nurse endoscopic departement
P6	Groene Hart ziekenhuis	Nurse endoscopic departement
P7	Groene Hart ziekenhuis	Nurse endoscopic departement
P8	Groene Hart ziekenhuis	Doctor endoscopic departement
P9	Startup reprocessing lab instruments	Co-founder
P10	Acibadum (Clinic)	Nurse endoscopic department
P11	Isala Zwolle	Focus group of five endoscopic nurses
P12	Isala Zwolle	Specialist invection prevention
P13	Isala Zwolle	Specialist sterile medical devices

## E: Sealing part material determination



Figure E.2: Samples are placed near the bottom in a glass of glycerine at the start of the test.



Figure E.3: Side view of float test results; polyp trap samples floating on top of the glycerine.



Figure E.4: Top view of float test results; polyp trap samples floating on top of the glycerine.

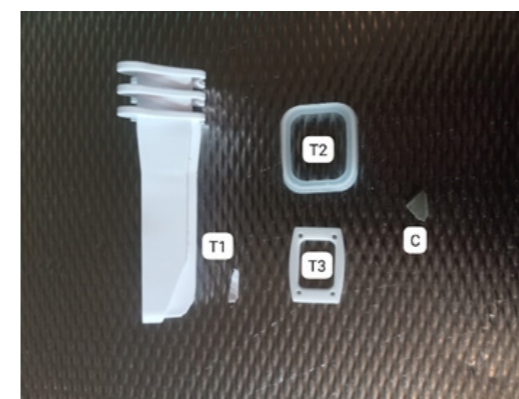

Figure E.1: Float test samples of the Steris eTrap, the ThomasTrap, the Endo-Safier and a control PVC sample, respectively T1, T2, T3 and C.



Figure E.5: Side view of float test results; PVC sample at bottom of glycerine filled glass.

# F. Fast-track LCA

## F.1 Input data fast-track LCA

Production							
Materials	Unit	Carbon footprint [kg CO2 equivalent]	Total eco-costs [€]	Eco-costs of human health [€]	Eco costs of eco toxicity [€]	Eco-costs of recourse scarcity [€]	Exo costs of carbon footprint [€]
Idemat2023 SAN (Styrene-acrylonitrile copolymer)	kg	2,96	1,289003648	0,011404252	0,079669396	0,83385	0,36408
Idemat2023 PC (Polycarbonate)	kg	3,4	1,274865277	0,008602347	0,053312931	0,79475	0,4182
Idemat2023 PE (HDPE, High density Polyethylene)	kg	1,8	1,156714514	0,039618368	0,045696146	0,85	0,2214
Idemat2023 PP (Polypropylene)	kg	1,63	1,133584073	0,037126936	0,045967137	0,85	0,20049
Idemat2023 PU (polyurethane) rubber for shoe soles	kg	4,359387398	1,42780377	0,020662378	0,075955685	0,794981057	0,53620465
Idemat2023 Silicone rubber (PDMS)	kg	7,334130488	1,768793545	0,111204592	0,431688841	0,323802062	0,90209805
Idemat2023 Stainless Steel (secondary), average	kg	1,965182276	0,427372304	0,044981909	0,124154033	0,016518942	0,24171742
Idemat2023 PET bottle grade	kg	2,19	1,026321012	0,069843048	0,067457964	0,61965	0,26937
Idemat2023 film LDPE 50 mu	m2	0,096060634	0,055667754	0,002217794	0,002265236	0,039369266	0,011815458
Idemat2023 Paper, woodfree uncoated, bleached, FSC	kg	0,41286674	0,089263353	0,007307925	0,01518895	0,015983869	0,050782609
Formaldehyde	kg	1,43982252	0,644776125	0,044032408	0,023275548	0,400369998	0,17709817
Process							
Manufacturing Processes		Carbon footprint [kg CO2 equivalent]	Total eco-costs [€]	Eco-costs of human health [€]	Eco costs of eco toxicity [€]	Eco-costs of recourse scarcity [€]	Exo costs of carbon footprint [€]
Idemat2023 injection moulding, machine only	kg	0,472082423	0,078761892	0,00250723	0,005528383	0,012660142	0,058066138
Idemat2023 injection moulding, incl production site	kg	1,20304878	0,200715794	0,006389393	0,014088459	0,032262943	0,147975
Idemat2023 thermo forming, machine only	kg	0,223350821	0,037263691	0,001186216	0,002615579	0,005989745	0,027472151
Idemat2023 thermo forming, incl production site	kg	0,456853959	0,076221186	0,002426352	0,005350048	0,01225175	0,056193037
Idemat2023 Deep drawing steel	kg	0,517485805	0,086336961	0,002748368	0,006060085	0,013877755	0,063650754
Means							
Transportation		Carbon footprint [kg CO2 equivalent]	Total eco-costs [€]	Eco-costs of human health [€]	Eco costs of eco toxicity [€]	Eco-costs of recourse scarcity [€]	Exo costs of carbon footprint [€]
Idemat2023 Truck+trailer 24 tons net (min weight/volume ratio 0,32 ton/m3) (tkm)	tkm	0,090508618	0,026000602	0,001333209	0,002176536	0,011358297	0,01113256
Idemat2023 Train, freight, electric (tkm)	tkm	0,01015231	0,001693804	5,39189E-05	0,00011889	0,000272261	0,001248734
Idemat2023 Container ship (min weight/volume ratio 0,41 ton/m3)	tkm	0,004775411	0,004775411	1,34977E-05	0,000168282	0,000622454	0,000587376
Incineration							
Materials		Carbon footprint [kg CO2 equivalent]	Total eco-costs [€]	Eco-costs of human health [€]	Eco costs of eco toxicity [€]	Eco-costs of recourse scarcity [€]	Exo costs of carbon footprint [€]
Idemat2023 ABS (Acrylonitrile butadiene styrene) co-firing in electrical power plant	kg	-0,027161624	-0,024644725	-0,005411243	-0,011957983	-0,00393462	-0,00334088
Idemat2023 PC (Polycarbonate) co-firing in electrical power plant	kg	0,443793935	0,03737394	-0,004446512	-0,0096553	-0,003110903	0,054586654
Idemat2023 PE (Polyethylene) co-firing in electrical power plant	kg	-0,558697358	-0,094174734	-0,006565915	-0,014279534	-0,00460951	-0,068719775
Idemat2023 PU (Polyurethane) co-firing in electrical power plant	kg	0,069398285	-0,011433978	-0,005533857	-0,011170179	-0,003265931	0,008535989
Idemat2023 Silicone rubber co-firing in electrical power plant	kg	0,218219146	0,009942956	-0,005398373	-0,00939124	-0,002108386	0,026840955
Idemat2023 Stainless Steel (secondary), average		Unknown					
Idemat2023 PET (Polyethylene terephthalate) co-firing in electrical power plant	kg	0,366013927	0,031832122	-0,003391044	-0,007398774	-0,002397772	0,045019713
Idemat2023 film LDPE 50 mu in power plant	m2	-0,02681252	-0,003166785	0,000299165	5,10965E-05	-0,000219107	-0,00329794
Idemat2023 Paper, Cardboard, Leather, Cotton (12% MC) co-firing in electrical power plant	kg	-1,633729512	-0,211559131	-0,002611606	-0,005962756	-0,002036039	-0,20094873

Figure F.1.1: Input data for fast track LCA of current products.



Production		Incineration		Fermentation		
Unit	Alternative materials	Carbon footprint [kg CO2 equivalent/kg]	Process	Carbon footprint [kg CO2 equivalent/kg]	Process	Carbon footprint [kg CO2 equivalent/kg]
	<b>Container</b>					
kg	Idemat2023 SAN (Styrene-acrylonitrile copolymer)*	2,96	Idemat2023 ABS (Acrylonitrile butadiene styrene) co-firing in electrical power plant	-0,027161624	-	-
kg	Idemat2023 PET bottle grade	2,19	Idemat2023 PET (Polyethylene terephthalate) co-firing in electrical power plant	0,366013927	-	-
kg	Idemat2023 PS (GPPS, general purpose polystyrene)	2,25	Idemat2023 PS (Polystyrene) co-firing in electrical power plant	-0,103078228	-	-
kg	Idemat2023 PMMA (Polymethyl methacrylate)	3,75	Idemat2023 PMMA (Polymethyl methacrylate) co-firing in electrical power plant	0,118446106	-	-
kg	Idemat2023 PC (Polycarbonate)	3,4	Idemat2023 PC (Polycarbonate) co-firing in electrical power plant	0,443793935	-	-
kg	Idemat2023 Mechanical recycled pellets (rPET, rPE, rPP, rPVC), downcycled	0,566414902	Idemat2023 PET (Polyethylene terephthalate) co-firing in electrical power plant	0,366013927	-	-
kg	Idemat2023 PMMA (Polymethyl methacrylate) chemical upcycled	4,474063333	Idemat2023 PMMA (Polymethyl methacrylate) co-firing in electrical power plant	0,118446106	-	-
kg	Idemat2023 PHA (Polyhydroxyalkanoates, biodegradable)	2,670585691	Idemat2023 PHA (Polyhydroxyalkanoates) co-firing in electrical power plant	-2,181070407	-	-
	<b>Drawer</b>					
kg	Idemat2023 PC (Polycarbonate)*	3,4	Idemat2023 PC (Polycarbonate) co-firing in electrical power plant	0,443793935	-	-
kg	Idemat2023 PE (HDPE, High density Polyethylene)*	1,8	Idemat2023 PE (Polyethylene) co-firing in electrical power plant	-0,558697358	-	-
kg	Idemat2023 PP (Polypropylene)	1,63	Idemat2023 PP (Polypropylene) co-firing in electrical power plant	-0,401129537	-	-
kg	Idemat2023 Mechanical recycled pellets (rPET, rPE, rPP, rPVC), downcycled	0,566414902	Idemat2023 PE (Polyethylene) co-firing in electrical power plant	-0,558697358	-	-
kg	Idemat2023 PE (Polyethylene) chemical upcycled	2,022987805	Idemat2023 PC (Polycarbonate) co-firing in electrical power plant	0,443793935	-	-
kg	Idemat2023 PC (Polycarbonate) chemical upcycled	3,826220813	Idemat2023 PE (Polyethylene) co-firing in electrical power plant	-0,558697358	-	-
kg	Idemat2023 bio-PE (Polyethylene) not biodegradable	1,87	Idemat2023 bio-PE (Polyethylene) co-firing in electrical power plant	-3,698697398	-	-
kg	Idemat2023 PHA (Polyhydroxyalkanoates, biodegradable)	2,670585691	Idemat2023 PHA (Polyhydroxyalkanoates) co-firing in electrical power plant	-2,181070407	Idemat2023 composting biodegradable plastics	0

\*Current materials

Figure F.1.2: Input data for fast track LCA of Alternative materials.

## F.2 Fast-track LCA current product

Endo-Safier

Component	Material	Manufacturing processes(es)	Number of components	Weight [kg]	Total Weight [kg]
Container	Styrene acrylonitrile (AS)	Injection moulding	1	0,037	0,037
Handle	Polycarbonate (PC)	Injection moulding	2	0,0082	0,0164
Sieve	Polyethylene (PE)	Injection moulding	2	0,0065	0,013
Tube holder	Polyethylene (PE)	Injection moulding	1	0,0038	0,0038
O-ring	Polyurethane (PU)	Injection moulding	2	0,0006	0,0012
Tube	Silicone	Blow moulding	1	0,015466667	0,015466667
retrieval sticker	PET	Injection moulding	1	0,001	0,001
Bag	LDPE		1	0,0078	0,0078
Front of retrieval sticker bag	LDPE		1	0,00459	0,00459
Back of retrieval sticker bag	Paper		1	0,0054	0,0054
Label	Paper		1	0,001	0,001
<b>Total</b>					<b>0,106656667</b>
<b>Total (1000 kg)</b>					<b>0,000106657</b>

Shipping distance Shanghai-Hamburg

Distance km	References
20385	<a href="https://www.fuentcargo.com/routes/shanghai-cn/hamburg-de#~:text=What%20is%20the%20distance%20between,20%2C35%20kilometres%20%2F%2012%2C67%20Miles">https://www.fuentcargo.com/routes/shanghai-cn/hamburg-de#~:text=What%20is%20the%20distance%20between,20%2C35%20kilometres%20%2F%2012%2C67%20Miles</a>
22551	<a href="http://ports.com/sea-route/port-of-shanghai,china/port-of-hamburg,germany/">http://ports.com/sea-route/port-of-shanghai,china/port-of-hamburg,germany/</a>
20268	<a href="https://app.searoutes.com/routing/search/core/DEHAM/CNSHA">https://app.searoutes.com/routing/search/core/DEHAM/CNSHA</a>
<b>21068</b>	

Carbon footprint [kg CO2 equivalent]	
<b>Total</b>	<b>0,43</b>
Material production	0,32
Manufacturing	0,10
Transport	0,02
Disposal	-0,01
Styrene acrylonitrile (AS)	0,10952
Polycarbonate (PC)	0,05576
Polyethylene (PE)	0,03024
Polyurethane (PU)	0,005231265
Silicone	0,113434552
PET	0,00219
LDPE	0,001190191
Paper	0,002642347

Eco-costs [€]	
<b>Total</b>	<b>0,15</b>
Human health	0,003
Eco toxicity	0,0123
Recourse scarcity	0,069980369
Carbon footprint	0,0531



Material production	Carbon footprint [kg CO2 equivalent]	Total eco-costs [€]	Eco-costs of human health [€]	Eco costs of eco toxicity [€]	Eco-costs of recourse scarcity [€]	Exo costs of carbon footprint [€]
<b>Part</b>	<b>Weight [kg]</b>					
Container	0,037	0,10962	0,047693135	0,000421967	0,002947768	0,03085245
Handle	0,0164	0,05576	0,02	0,000141078	0,000874332	0,0130339
Sieve	0,013	0,0234	0,02	0,000515039	0,00059405	0,01105
Tube holder	0,0038	0,00684	0,004395515	0,00015055	0,000173645	0,00323
O-ring	0,0012	0,005231265	0,001713365	2,47949E-05	9,11468E-05	0,000953977
Tube	0,015466667	0,113434552	0,03	0,001719964	0,006676787	0,005008139
retrieval sticker	0,001	0,00219	0,001026321	6,6843E-06	6,7458E-06	0,00081968
Bag	0,0078	0,000749273	0,000434208	1,72988E-05	1,78688E-05	0,00030708
Front of retrieval sticker bag	0,00459	0,000440818	0,000255515	1,01767E-05	1,03974E-05	0,000180705
Back of retrieval sticker bag	0,0054	0,00222948	0,000482022	3,04628E-05	8,20203E-05	8,83129E-05
Label	0,001	0,000412867	8,92834E-05	7,30792E-06	1,69839E-05	5,07828E-05
<b>Total</b>		<b>0,32</b>	<b>0,12</b>	<b>0,003</b>	<b>0,011550463</b>	<b>0,065338198</b>
<b>Manufacturing</b>	<b>Carbon footprint [kg CO2 equivalent]</b>	<b>Total eco-costs [€]</b>	<b>Eco-costs of human health [€]</b>	<b>Eco costs of eco toxicity [€]</b>	<b>Eco-costs of recourse scarcity [€]</b>	<b>Exo costs of carbon footprint [€]</b>
<b>Process</b>	<b>Weight [kg]</b>					
Injection moulding	0,0724	0,087100732	0,01	0,000462592	0,001020004	0,002335837
Blow moulding	0,015466667	0,017507998	0,002921022	9,2985E-05	0,00020503	0,000469523
<b>Total</b>		<b>0,10</b>	<b>0,02</b>	<b>0,001</b>	<b>0,001225034</b>	<b>0,00280536</b>
<b>Transport</b>	<b>Carbon footprint [kg CO2 equivalent]</b>	<b>Total eco-costs [€]</b>	<b>Eco-costs of human health [€]</b>	<b>Eco costs of eco toxicity [€]</b>	<b>Eco-costs of recourse scarcity [€]</b>	<b>Exo costs of carbon footprint [€]</b>
<b>From-to</b>	<b>Mode</b>	<b>Distance [km]</b>				
Suzhou, Jiangsu-Shanghai	Truck	110				
Shanghai-Hamburg	Boat	21068	0,01	0,0107	3,03298E-05	0,0004
Hamburg-Lemmer	Truck	372				
Lemmer-Gouda	Truck	151				
	Truck	633	0,01	0,0018	9,00098E-05	0,0001
			0,02	0,0125	0,00012034	0,0005
					0,002165522	0,0021
<b>Disposal</b>	<b>Carbon footprint [kg CO2 equivalent]</b>	<b>Total eco-costs [€]</b>	<b>Eco-costs of human health [€]</b>	<b>Eco costs of eco toxicity [€]</b>	<b>Eco-costs of recourse scarcity [€]</b>	<b>Exo costs of carbon footprint [€]</b>
<b>Part</b>	<b>Weight [kg]</b>					
Container	0,037	-0,00100498	-0,000911855	-0,000200216	-0,000442445	-0,000145581
Handle	0,0164	0,007278221	0,000612933	-7,29228E-05	-0,000158347	-5,10188E-05
Sieve	0,013	-0,007263066	-0,001224272	-8,53569E-05	-0,000185634	-5,99236E-05
Tube holder	0,0038	-0,00212305	-0,000357864	-2,49505E-05	-5,42622E-05	-1,75161E-05
O-ring	0,0012	8,32779E-05	-1,37208E-05	-6,64063E-06	-1,34042E-05	-3,91912E-06
Tube	0,015466667	0,003376123	0,000153784	-8,34948E-05	-0,000145251	-3,28097E-05
retrieval sticker	0,001	0,000386014	3,18321E-05	-3,39104E-06	-7,39877E-06	-2,39777E-06
Bag	0,0078	-0,000209138	-2,47009E-05	2,33349E-06	3,88552E-07	-1,70903E-06
Front of retrieval sticker bag	0,00459	-0,000123069	-1,45355E-05	1,37317E-06	2,34633E-07	-1,0067E-06
Back of retrieval sticker bag	0,0054	-0,008822139	-0,001142419	-1,41027E-05	-3,21989E-05	-1,09946E-05
Label	0,001	-0,00183373	-0,000211559	-2,61161E-06	-5,96276E-06	-2,03604E-06
<b>Total</b>		<b>-0,010076536</b>	<b>-0,003102377</b>	<b>-0,00048998</b>	<b>-0,001044271</b>	<b>-0,000328711</b>
<b>Total</b>		<b>0,43</b>	<b>0,15</b>	<b>0,003</b>	<b>0,0123</b>	<b>0,069980369</b>

Figure F.2.1: Fast-track LCA calculation Endo-Safier.



## F.2 Fast-track LCA current product

ThomasTrap

Component	Material	Manufacturing process	number of components	Weight [kg]	il Weight [kg]
Container	Styrene acrylonitrile (AS)	Injection moulding	1	0,2841	0,2841
Handle	Polyethylene (PE)	Injection moulding	2	0,0021	0,0042
Sieve	Polyethylene (PE)	Injection moulding	2	0,0092	0,0184
Lid part	Polyethylene (PE)	Injection moulding	2	0,003667	0,00733333
O-ring	Polyurethane (PU)	Injection moulding	2	0,0011	0,0022
Tube	Silicone	Blow moulding	1	0,011133	0,01113333
Spring	Stainless steel	Deep drawing	2	0,001733	0,00346667
retrieval sticker	PET	Injection moulding	2	0,005033	0,01006667
Tube holder	PET	Injection moulding	1	0,00023	0,00023
Front of bag	LDPE		1	0,00326	0,00326
Back of bag	Paper		1	0,00384	0,00384
Label	Paper		1	0,000533	0,00053333
<b>Total</b>					<b>0,34876333</b>
<b>Total [1000 kg]</b>					<b>0,00034876</b>

Shipping distance Hongkong-Hamburg

Distance km	References
21782	<a href="https://www.fluentcargo.com/routes/hamburg-de/hong-kong-hk">https://www.fluentcargo.com/routes/hamburg-de/hong-kong-hk</a>
11416	<a href="http://ports.com/sea-route/port-of-hong-kong,hong-kong/port-of-hamburg,germany/">http://ports.com/sea-route/port-of-hong-kong,hong-kong/port-of-hamburg,germany/</a>
18831	<a href="https://app.searoutes.com/routing/search/core/HKHKG/DEHAM?routing=%7B%22p%22%3A%5B%7B%22c%">https://app.searoutes.com/routing/search/core/HKHKG/DEHAM?routing=%7B%22p%22%3A%5B%7B%22c%</a>
<b>17343</b>	

	Carbon footprint [kg CO2 equivalent]
<b>Total</b>	<b>1,45</b>
Material production	1,02
Manufacturing	0,41
Transport	0,05
Disposal	-0,03
Styrene acrylonitrile (AS)	0,840936
Polyethylene (PE)	0,05388
Polyurethane (PU)	0,009590652
Silicone	0,081653319
Stainless steel	0,006812632
PET	0,0225497
LDPE	0,000313158
Paper	0,001805604



	Eco-costs [€]
<b>Total</b>	<b>0,53</b>
Human health	0,007
Eco toxicity	0,0323
Recourse scarcity	0,289815939
Carbon footprint	0,1778

Material production	Carbon footprint [kg CO2 equivalent]	Total eco-costs [€]	Eco-costs of human health [€]	Eco costs of eco toxicity [€]	Eco-costs of recourse scarcity [€]	Exo costs of carbon footprint [€]	
<b>Part</b>	<b>Weight [kg]</b>						
Container	0,2841	0,840936	0,366205936	0,003239948	0,022634075	0,236896785	0,103435128
Handle	0,0042	0,00756	0,00	0,000166397	0,000191924	0,00357	0,00092988
Sieve	0,0184	0,03312	0,02	0,000728978	0,000840809	0,01564	0,00407376
Lid part	0,007333333	0,0132	0,008482573	0,000290535	0,000335105	0,006233333	0,0016236
O-ring	0,0022	0,009590652	0,003141168	4,54572E-05	0,000167103	0,001748958	0,00117965
Tube	0,011133333	0,081653319	0,02	0,001238078	0,004806136	0,003604996	0,010043358
Spring	0,003466667	0,006812632	0,001481557	0,000155937	0,000430401	5,72657E-05	0,000837954
retrieval sticker	0,010066667	0,022046	0,010331632	0,000703087	0,000679077	0,00623781	0,002711658
Tube holder	0,00023	0,0005037	0,000236054	1,60639E-05	1,55153E-05	0,00014252	6,19551E-05
Front of bag	0,00326	0,000313158	0,000181477	7,23001E-06	7,38467E-06	0,000128344	3,85184E-05
Back of bag	0,00384	0,001585408	0,000342771	2,80624E-05	5,83256E-05	6,13781E-05	0,000195005
Label	0,000533333	0,000220196	4,76071E-05	3,89756E-06	8,10077E-06	8,52473E-06	2,70841E-05
<b>Total</b>		<b>1,02</b>	<b>0,44</b>	<b>0,007</b>	<b>0,030173956</b>	<b>0,274329915</b>	<b>0,125157551</b>

Manufacturing	Carbon footprint [kg CO2 equivalent]	Total eco-costs [€]	Eco-costs of human health [€]	Eco costs of eco toxicity [€]	Eco-costs of recourse scarcity [€]	Exo costs of carbon footprint [€]	
<b>Process</b>	<b>Weight [kg]</b>						
Injection moulding	0,32653	0,392831518	0,07	0,002086328	0,004600304	0,010534819	0,048318277
Blow moulding	0,011133333	0,01260274	0,002102632	6,69332E-05	0,000147586	0,000337976	0,001550137
Deep drawing	0,003466667	0,001793951	0,000299301	9,52767E-06	2,10083E-05	4,81095E-05	0,000220656
<b>Total</b>		<b>0,41</b>	<b>0,07</b>	<b>0,002</b>	<b>0,004768899</b>	<b>0,010920904</b>	<b>0,05008907</b>

Transport	Carbon footprint [kg CO2 equivalent]	Total eco-costs [€]	Eco-costs of human health [€]	Eco costs of eco toxicity [€]	Eco-costs of recourse scarcity [€]	Exo costs of carbon footprint [€]		
<b>From-to</b>	<b>Mode</b>	<b>Distance [km]</b>						
Sha Tin - Hong Kong								
harbour	Truck	12,4						
Shanghai-Hamburg	Boat	17343	0,03	0,0289	8,16421E-05	0,0010	0,003764979	0,0036
Hamburg-Lemmer	Truck	372						
Lemmer-Gouda	Truck	151						
	Truck	535,4	0,02	0,0049	0,000248947	0,0004	0,002120911	0,0021
<b>Total</b>			<b>0,05</b>	<b>0,0337</b>	<b>0,000330589</b>	<b>0,0014</b>	<b>0,00588589</b>	<b>0,0056</b>

Disposal	Carbon footprint [kg CO2 equivalent]	Total eco-costs [€]	Eco-costs of human health [€]	Eco costs of eco toxicity [€]	Eco-costs of recourse scarcity [€]	Exo costs of carbon footprint [€]	
<b>Part</b>	<b>Weight [kg]</b>						
Container	0,2841	-0,007716617	-0,007001566	-0,001537334	-0,003397263	-0,001117826	-0,000949144
Handle	0,0042	-0,002346529	-0,000395534	-2,75768E-05	-5,9974E-05	-1,93599E-05	-0,000288623
Sieve	0,0184	-0,010280031	-0,001732815	-0,000120813	-0,000262743	-8,4815E-05	-0,001264444
Lid part	0,007333333	-0,004097114	-0,000690615	-4,815E-05	-0,000104717	-3,38031E-05	-0,000503945
O-ring	0,0022	0,000152676	-2,51548E-05	-1,21745E-05	-2,45744E-05	-7,18505E-06	1,87792E-05
Tube	0,011133333	0,002429506	0,000110698	-6,01019E-05	-0,000104556	-2,34734E-05	0,000298829
Spring	0,003466667	0	0	0	0	0	0
retrieval sticker	0,010066667	0,00368454	0,000320443	-3,41365E-05	-7,4481E-05	-2,41376E-05	0,000453198
Tube holder	0,00023	8,41832E-05	7,32139E-06	-7,7994E-07	-1,70172E-06	-5,51488E-07	1,03545E-05
Front of bag	0,00326	-8,74088E-05	-1,03237E-05	9,75278E-07	1,66574E-07	-7,14288E-07	-1,07513E-05
Back of bag	0,00384	-0,006273521	-0,000812387	-1,00286E-05	-2,2897E-05	-7,81839E-06	-0,000771643
Label	0,000533333	-0,000871322	-0,000112832	-1,39286E-06	-3,18014E-06	-1,08589E-06	-0,000107173
<b>Total</b>		<b>-0,025321638</b>	<b>-0,010342764</b>	<b>-0,001851513</b>	<b>-0,00405592</b>	<b>-0,00132077</b>	<b>-0,003114561</b>
<b>Total</b>		<b>1,45</b>	<b>0,53</b>	<b>0,007</b>	<b>0,0323</b>	<b>0,289815939</b>	<b>0,1778</b>

Figure F.2.2: Fast-track LCA calculation ThomasTrap



## F.2 Fast-track LCA current product

Steris E-Trap

Component	Material	Manufacturing process	Number of component	Weight [kg]	Total Weight [kg]
Container	Styrene acrylonitrile (AS)	Injection moulding	1	0,0336	0,0336
Tray	Thermoplastic elastomer (TPE)	Injection moulding	2	0,008916667	0,017833333
Tube	Silicone	Blow moulding	1	0,0123	0,0123
Packaging tray	PET	Thermoforming	1	0,028666667	0,028666667
Label	Paper	Printing, glueing	1	0,001	0,001
<b>Total weight</b>					<b>0,0934</b>
<b>Total weight (ton)</b>					<b>0,0000934</b>

Shipping distance Norfolk, USA - Rotterdam, NL

Distance [km]	References
7740	<a href="http://ports.com/sea-route/port-of-rotterdam,netherlands/port-of-port-norfolk,united-states/">http://ports.com/sea-route/port-of-rotterdam,netherlands/port-of-port-norfolk,united-states/</a>
6630	<a href="https://www.routescanner.com/app/voyages/detail?departure=2023-04-14&amp;sort=emission_co2&amp;fromType=address&amp;from=eylsb2N">https://www.routescanner.com/app/voyages/detail?departure=2023-04-14&amp;sort=emission_co2&amp;fromType=address&amp;from=eylsb2N</a>
7154	<a href="https://www.fluentcargo.com/routes/rotterdam-nl/norfolk-us">https://www.fluentcargo.com/routes/rotterdam-nl/norfolk-us</a>
<b>7174,666667</b>	

Carbon footprint [kg CO2 equivalent]	
Total	0,44
Material production	0,33
Manufacturing	0,09
Transport	0,005921026
Disposal	0,011867737
Styrene acrylonitrile (A)	0,099456
Thermoplastic elastom	0,077742409
Silicone	0,090209805
PET	0,06278
Paper	0,000412867

Eco-costs [€]	
Total	0,14
Human health	0,004
Eco toxicity	0,01156153
Recourse scarcity	0,066705333
Carbon footprint	0,053786242



Material production		Carbon footprint [kg CO2 equivalent]	Total eco-costs [€]	Eco-costs of human health	Eco costs of eco toxicity [€]	Eco-costs of recourse scarcity [€]	Exo costs of carbon footprint
<b>Part</b>	<b>Weight [kg]</b>						
Container	0,0336	0,099456	0,04	0,000383183	0,002676892	0,02801736	0,012233088
Tray	0,0178333	0,077742409	0,03	0,000368479	0,001354543	0,014177162	0,009562316
Tube	0,0123	0,090209805	0,021756161	0,001367816	0,005309773	0,003982765	0,011095806
Packaging tray	0,0286667	0,06278	0,029421202	0,002002167	0,001933795	0,0177633	0,00772194
Label	0,001	0,000412867	0,00	7,30792E-06	1,51889E-05	1,59839E-05	5,07826E-05
<b>Total</b>	<b>0,33</b>	<b>0,33</b>	<b>0,12</b>	<b>0,004</b>	<b>0,011290191</b>	<b>0,063956571</b>	<b>0,040663933</b>
Manufacturing		Carbon footprint [kg CO2 equivalent]	Total eco-costs [€]	Eco-costs of human health	Eco costs of eco toxicity [€]	Eco-costs of recourse scarcity [€]	Exo costs of carbon footprint
<b>Process</b>	<b>Weight [kg]</b>						
Injection moulding	0,0514333	0,061876809	0,01	0,000328628	0,000724616	0,001659391	0,007610848
Blow moulding	0,0123	0,013923386	0,002322968	7,39471E-05	0,000163052	0,000373393	0,001712576
Thermoforming	0,0286667	0,01309648	0,00	6,95554E-05	0,000153368	0,000351217	0,001610867
<b>Total</b>	<b>0,09</b>	<b>0,09</b>	<b>0,01</b>	<b>0,000</b>	<b>0,001041036</b>	<b>0,002384</b>	<b>0,010934291</b>
Transport		Carbon footprint [kg CO2 equivalent]	Total eco-costs [€]	Eco-costs of human health	Eco costs of eco toxicity [€]	Eco-costs of recourse scarcity [€]	Exo costs of carbon footprint
<b>From-to</b>	<b>Mode</b>	<b>Distance [km]</b>					
Mentor, USA - Cleavelant Rail		41					
Cleavelant, USA - Norfolk Rail		1071					
Norfolk, USA - Virginia I Rail		28					
	<b>Rail</b>	<b>1140</b>	<b>0,001080977</b>	<b>0,000180349</b>	<b>5,74107E-06</b>	<b>1,26589E-05</b>	<b>2,89893E-05</b>
Norfolk, USA - Rotterdam	Ship	7174,666667	0,00	0,0032	9,04498E-06	0,0001	0,000417115
Rotterdam, NL - Lemme Truck		169					
Lemmer, NL - Gouda, N	Truck	25					
	<b>Truck</b>	<b>194</b>	<b>0,00163998</b>	<b>0,000471121</b>	<b>2,41572E-05</b>	<b>3,9438E-05</b>	<b>0,000205808</b>
<b>Total</b>			<b>0,005921026</b>	<b>0,003851539</b>	<b>3,89433E-05</b>	<b>0,000164865</b>	<b>0,000728288</b>
Disposal		Carbon footprint [kg CO2 equivalent]	Total eco-costs [€]	Eco-costs of human health	Eco costs of eco toxicity [€]	Eco-costs of recourse scarcity [€]	Exo costs of carbon footprint
<b>Part</b>	<b>Weight [kg]</b>						
Container	0,0336	-0,000912631	-0,000828063	-0,000181818	-0,000401788	-0,000132203	-0,000112254
Tray	0,0178333	0,001237603	-0,000203906	-9,86871E-05	-0,000199202	-5,82424E-05	0,000152225
Tube	0,0123	0,002684096	0,000122298	-6,64E-05	-0,000115512	-2,59331E-05	0,000330144
Packaging tray	0,0286667	0,010492399	0,000912521	-9,72099E-05	-0,000212098	-6,87361E-05	0,001290565
Label	0,001	-0,00163373	-0,000211559	-2,61161E-06	-5,96276E-06	-2,03604E-06	-0,000200945
<b>Total</b>	<b>0,11867737</b>	<b>-0,000208709</b>	<b>-0,000446726</b>	<b>-0,000934563</b>	<b>-0,000287151</b>	<b>-0,000287151</b>	<b>0,001459732</b>
<b>Total</b>	<b>0,44</b>	<b>0,44</b>	<b>0,14</b>	<b>0,004</b>	<b>0,01156153</b>	<b>0,066705333</b>	<b>0,053786242</b>

Figure F.2.3: Fast-track LCA calculation Steris eTrap

## F.2 Fast-track LCA current product

Formalin cup (50 mL)

Component	Material	Manufacture number of component	Weight [kg]	Weight [kg]
Container	Polypropylene (F Injection mould)	1	0,006155	0,006155
Cap	Polyethylene (PE Injection mould)	1	0,004095	0,004095
Label	Paper	100%	0,0002667	0,0002667
Preserving fluid	Formaldehyde	-	4%	0,0327
Preserving fluid	Methane	-	1,00%	0,002373
Preserving fluid	Water	-	95,30%	0,02853282
<b>Formalin 10%</b>				
Total weight [kg]				0,04049669
Total weight [1000 kg]				4,0497E-05

Distance [km]	References
7740	<a href="http://ports.com/sea-route/port-of-rotterdam,netherlands/port-of-port-norfolk,united-stat">http://ports.com/sea-route/port-of-rotterdam,netherlands/port-of-port-norfolk,united-stat</a>
6630	<a href="https://www.routescanner.com/app/voyages/detail?departure=2023-04-14&amp;sort=emissio">https://www.routescanner.com/app/voyages/detail?departure=2023-04-14&amp;sort=emissio</a>
7154	<a href="https://www.fluentcargo.com/routes/rotterdam-nl/norfolk-us">https://www.fluentcargo.com/routes/rotterdam-nl/norfolk-us</a>
<b>7174,666667</b>	

	Carbon footprint [kg CO2 equivalent]
Total	0,03
Material production	0,02
Manufacturing	0,01
Transport	0,002567259
Disposal	-0,005179867

	Eco-costs [€]
Total	0,02
Human health	0,000
Eco toxicity	0,000572555
Recourse scarcity	0,009766553
Carbon footprint	0,00360588

Material production		Carbon footprint [kg CO2 equivalent]	Total eco-costs [€]
Part	Weight [kg]		
Container	0,006155	0,01003265	0,01
Cap	0,004095	0,007371	0,00
Label	0,000266667	0,000110098	2,38036E-05
Preserving fluid	0,0012099	0,001742041	0,000780115
Preserving fluid	<u>0,0002373</u>	<u>0,00034167</u>	0,00
Preserving fluid	0,02853282	0,000247595	8,23652E-05
<b>Total</b>		<b>0,02</b>	<b>0,01</b>

Manufacturing		Carbon footprint [kg CO2 equivalent]	Total eco-costs [€]
Process	Weight [kg]		
Injection moulding	0,01025	0,01233125	0,00
<b>Total</b>		<b>0,01</b>	<b>0,00</b>

Transport		Carbon footprint [kg CO2 equivalent]	Total eco-costs [€]
From-to	Mode	Distance [km]	
Mentor, USA-Cleveland, USA	Rail	41	
Cleveland, USA - Norfolk, USA	Rail	1071	
Norfolk, USA - Virginia International	Rail	28	
		<b>Rail</b>	<b>1140</b>
			<b>0,000468694</b>
			<b>7,81965E-05</b>
Norfolk, USA - Rotterdam, NL	<b>Ship</b>	7174,666667	0,00
Rotterdam, NL - Lemmer, NL	Truck	169	
Lemmer, NL - Gouda, NL	Truck	25	
		<b>Truck</b>	<b>194</b>
			<b>0,000711068</b>
			<b>0,00020427</b>
<b>Total</b>		<b>0,002567259</b>	<b>0,001669963</b>

Disposal		Carbon footprint [kg CO2 equivalent]	Total eco-costs [€]
Part	Weight [kg]		
Container	0,006155	-0,002468952	-0,000453867
Cap	0,004095	-0,002287866	-0,000385646
Label	0,000266667	-0,000435661	-5,64158E-05
Preserving fluid	0,0012099	1,26124E-05	-1,05893E-05
Preserving fluid	0,0002373	0	0
Preserving fluid	0,02853282	0	0
<b>Total</b>		<b>-0,005179867</b>	<b>-0,000906518</b>
<b>Total</b>		<b>0,03</b>	<b>0,02</b>

Figure F.2.4: Fast-track LCA calculation 30 mL formalin cup

## F.2 Fast-track LCA current product

Formalin cup (50 mL)					
Component	Material	Manufacturing processes(es)	Number of components	Weight [kg]	Total Weight [kg]
Container	Polypropylene (PP)	Injection moulding	1	0,008105	0,008105
Cap	Polyethylene (PE)	Injection moulding	1	0,0048	0,0048
Label	Paper		100%	0,000266667	0,000266667
Preserving fluid	Formaldehyde	-	4%	0,0545	0,0020165
Preserving fluid	Methane	-	1,00%	0,03955	0,0003955
Preserving fluid	Water	-	95,30%	0,0499	0,0475547
Formalin 10%					
Total weight [kg]					<b>0,063138367</b>
Total weight [1000 kg]					<b>6,31384E-05</b>
Distance [km]	References				
7740	<a href="http://ports.com/sea-route/port-of-rotterdam,netherlands/port-of-port-norfolk,united-states/">http://ports.com/sea-route/port-of-rotterdam,netherlands/port-of-port-norfolk,united-states/</a>				
6630	<a href="https://www.routescanner.com/app/voyages/detail?departure=2023-04-14&amp;sort=emission_co2&amp;fromType=address&amp;from=eyJsb2NhdGlvbil6eyjYXQlQjQxLjY2NjUwLmN1Ij09">https://www.routescanner.com/app/voyages/detail?departure=2023-04-14&amp;sort=emission_co2&amp;fromType=address&amp;from=eyJsb2NhdGlvbil6eyjYXQlQjQxLjY2NjUwLmN1Ij09</a>				
7154	<a href="https://www.fluentcargo.com/routes/rotterdam-nl/norfolk-us">https://www.fluentcargo.com/routes/rotterdam-nl/norfolk-us</a>				
<b>7174,666667</b>					
Carbon footprint [kg CO2 equivalent]					
Total	0,04				
Material production	0,03				
Manufacturing	0,02				
Transport	0,004002612				
Disposal	-0,006347543				
Eco-costs [€]					
Total	0,02				
Human health	0,001				
Eco toxicity	0,000752935				
Recourse scarcity	0,012577152				
Carbon footprint	0,004749585				

Material production		Carbon footprint [kg CO2 equivalent]	Total eco-costs [€]
Part	Weight [kg]		
Container	0,008105	0,01321115	0,01
Cap	0,0048	0,00864	0,01
Label	0,000266667	0,000110098	2,38036E-05
Preserving fluid	0,0020165	0,002903402	0,001300191
Preserving fluid	0,0003955	0,00056945	0,00
Preserving fluid	0,0475547	0,000412658	0,000137275
<b>Total</b>		<b>0,03</b>	<b>0,02</b>

Manufacturing		Carbon footprint [kg CO2 equivalent]	Total eco-costs [€]
Process	Weight [kg]		
Injection moulding	0,012905	0,015525345	0,00
<b>Total</b>		<b>0,02</b>	<b>0,00</b>

Transport		Carbon footprint [kg CO2 equivalent]	Total eco-costs [€]
From-to	Mode	Distance [km]	
Mentor, USA-Cleveland, USA	Rail	41	
Cleveland, USA - Norfolk, USA	Rail	1071	
Norfolk, USA - Virginia International Gateway	Rail	28	
	<b>Rail</b>	<b>1140</b>	<b>0,00073074</b>
Norfolk, USA - Rotterdam, NL	<b>Ship</b>	<b>7174,667</b>	<b>0,00</b>
Rotterdam, NL - Lemmer, NL	Truck	169	
Lemmer, NL - Gouda, NL	Truck	25	
	<b>Truck</b>	<b>194</b>	<b>0,001108626</b>
<b>Total</b>			<b>0,004002612</b>
<b>Total</b>			<b>0,002603639</b>

Disposal		Carbon footprint [kg CO2 equivalent]	Total eco-costs [€]
Part	Weight [kg]		
Container	0,008105	-0,003251155	-0,00059766
Cap	0,0048	-0,002681747	-0,000452039
Label	0,000266667	-0,000435661	-5,64158E-05
Preserving fluid	0,0020165	2,10207E-05	-1,76488E-05
Preserving fluid	0,0003955	0	0
Preserving fluid	0,0475547	0	0
<b>Total</b>		<b>-0,006347543</b>	<b>-0,001123763</b>
<b>Total</b>		<b>0,04</b>	<b>0,02</b>

Figure F.2.5: Fast-track LCA calculation 50mL formalin cup



## F.3 Alternative polyp traps

Thin walled polyp trap

Component	Material	Manufacturing processes(es)	Number of components	Weight [kg]	Total Weight [kg]
Container	Styrene acrylonitrile (AS)	Injection moulding	1	0,021142857	0,021142857
Handle	Polycarbonate (PC)	Injection moulding	2	0	0
Sieve	Polyethylene (PE)	Injection moulding	2	0,003714286	0,007428571
Tube holder	Polyethylene (PE)	Injection moulding	1	0,002171429	0,002171429
O-ring	Polyurethane (PU)	Injection moulding	2	0,0006	0,0012
Tube	Silicone	Blow moulding	1	0,015466667	0,015466667
retrieval sticker	PET	Injection moulding	1	0,001	0,001
Bag	LDPE		1	0,0078	0,0078
Front of retrieval sticker bag	LDPE		1	0,00459	0,00459
Back of retrieval sticker bag	Paper		1	0,0054	0,0054
Label	Paper		1	0,001	0,001
<b>Total</b>					<b>0,067199524</b>
<b>Total [1000 kg]</b>					<b>6,71995E-05</b>

Shipping distance Shanghai-Hamburg

Distance km	References
20385	<a href="https://www.fluentcargo.com/routes/shanghai-cn/hamburg-de#:~:text=What%20is%20the%20distance%20between,%202C385%20Kilometres%20%2F%2012%2C667%20Miles">https://www.fluentcargo.com/routes/shanghai-cn/hamburg-de#:~:text=What%20is%20the%20distance%20between,%202C385%20Kilometres%20%2F%2012%2C667%20Miles</a>
22551	<a href="http://ports.com/sea-route/port-of-shanghai,china/port-of-hamburg,germany/">http://ports.com/sea-route/port-of-shanghai,china/port-of-hamburg,germany/</a>
20268	<a href="https://app.searoutes.com/routing/search/core/DEHAM/CNSHA">https://app.searoutes.com/routing/search/core/DEHAM/CNSHA</a>
<b>21068</b>	

	Carbon footprint [kg CO2 e / 1000 kg]
<b>Total</b>	<b>0,26</b>
Material production	0,20
Manufacturing	0,06
Transport	0,01
Disposal	0,26
Styrene acrylonitrile (AS)	0,062582857
Polycarbonate (PC)	0
Polyethylene (PE)	0,01728
Polyurethane (PU)	0,005231265
Silicone	0,113434552
PET	0,00219
LDPE	0,001190191
Paper	0,002642347

Current wall depth	1,75
New wall depth	1,00
Size decrease	0,571

Material production		Carbon footprint [kg CO2 e]
Part	Weight [kg]	
Container	0,021142857	0,062582857
Handle	0	0
Sieve	0,007428571	0,013371429
Tube holder	0,002171429	0,003908571
O-ring	0,0012	0,005231265
Tube	0,015466667	0,113434552
retrieval sticker	0,001	0,00219
Bag	0,0078	0,000749273
Front of retrieval sticker bag	0,00459	0,000440918
Back of retrieval sticker bag	0,0054	0,00222948
Label	0,001	0,000412867
<b>Total</b>		<b>0,20</b>

Manufacturing		Carbon footprint [kg CO2 e]
Process	Weight [kg]	
Injection moulding	0,032942857	0,039631864
Blow moulding	0,015466667	0,017507998
<b>Total</b>		<b>0,06</b>

Transport		Carbon footprint [kg CO2 e]
From-to	Mode	Distance [km]
Suzhou, Jiangsu-Shanghai	Truck	110
Shanghai-Hamburg	Boat	21068
Hamburg-Lemmer	Truck	372
Lemmer-Gouda	Truck	151
	Truck	633
		0,00
		0,01

Disposal		Carbon footprint [kg CO2 e]
Part	Weight [kg]	
Container	0,021142857	-0,000574274
Handle	0	0
Sieve	0,007428571	-0,004150323
Tube holder	0,002171429	-0,001213171
O-ring	0,0012	8,32779E-05
Tube	0,015466667	0,003375123
retrieval sticker	0,001	0,000366014
Bag	0,0078	-0,000209138
Front of retrieval sticker bag	0,00459	-0,000123069
Back of retrieval sticker bag	0,0054	-0,008822139
Label	0,001	-0,00163373
<b>Total</b>		<b>-0,01290143</b>
<b>Total</b>		<b>0,26</b>

Figure F.3.1 Thin walled polyp trap

## F.3 Alternative polyp traps

Alternative fossil based polyp trap

Component	Material	Manufacturing processes(ses)	Number of components	Weight [kg]	Total Weight [kg]
Container	Polyethylene terephthalate (PET)	Injection moulding	1	0,037	0,037
Handle	Polypropylene (PP)	Injection moulding	2	0,0082	0,0164
Sieve	Polypropylene (PP)	Injection moulding	2	0,0065	0,013
Tube holder	Polypropylene (PP)	Injection moulding	1	0,0038	0,0038
O-ring	Polyurethane (PU)	Injection moulding	2	0,0006	0,0012
Tube	Silicone	Blow moulding	1	0,015466667	0,015466667
retrieval sticker	PET	Injection moulding	1	0,001	0,001
Bag	LDPE		1	0,0078	0,0078
Front of retrieval sticker bag	LDPE		1	0,00459	0,00459
Back of retrieval sticker bag	Paper		1	0,0054	0,0054
Label	Paper		1	0,001	0,001
<b>Total</b>					<b>0,106656667</b>
<b>Total [1000 kg]</b>					<b>0,000106657</b>

Shipping distance Shanghai-Hamburg

Distance km	References
20385	<a href="https://www.fluentcargo.com/routes/shanghai-cn/hamburg-de#:~:text=What%20is%20the%20distance%20between,%20%2C385%20Kilometres%20%2F%2012%2C667%20M">https://www.fluentcargo.com/routes/shanghai-cn/hamburg-de#:~:text=What%20is%20the%20distance%20between,%20%2C385%20Kilometres%20%2F%2012%2C667%20M</a>
22551	<a href="http://ports.com/sea-route/port-of-shanghai,china/port-of-hamburg,germany/">http://ports.com/sea-route/port-of-shanghai,china/port-of-hamburg,germany/</a>
20268	<a href="https://app.searoutes.com/routing/search/core/DEHAM/CNSHA">https://app.searoutes.com/routing/search/core/DEHAM/CNSHA</a>
<b>21068</b>	

Carbon footprint [kg CO2 equivalent]	
<b>Total</b>	<b>0,37</b>
Material production	0,26
Manufacturing	0,10
Transport	0,02
Disposal	0,37
Styrene acrylonitrile (AS)	0,08103
Polypropylene (PP)	0,026732
Polypropylene (PP)	0,027384
Polyurethane (PU)	0,005231265
Silicone	0,113434552
PET	0,00219
LDPE	0,001190191
Paper	0,002642347

Eco-costs [€]	
<b>Total</b>	<b>0,00</b>
Human health	0,000
Eco toxicity	0,0000
Recourse scarcity	0
Carbon footprint	0,0000

Material production		Carbon footprint [kg CO2 equivalent]
Part	Weight [kg]	
Container	0,037	0,08103
Handle	0,0164	0,026732
Sieve	0,013	0,02119
Tube holder	0,0038	0,006194
O-ring	0,0012	0,005231265
Tube	0,015466667	0,113434552
retrieval sticker	0,001	0,00219
Bag	0,0078	0,000749273
Front of retrieval sticker bag	0,00459	0,000440918
Back of retrieval sticker bag	0,0054	0,00222948
Label	0,001	0,000412867
<b>Total</b>		<b>0,26</b>

Manufacturing		Carbon footprint [kg CO2 equivalent]
Process	Weight [kg]	
Injection moulding	0,0724	0,087100732
Blow moulding	0,015466667	0,017507998
<b>Total</b>		<b>0,10</b>

Transport			Carbon footprint [kg CO2 equivalent]
From-to	Mode	Distance [km]	
Suzhou, Jiangsu-Shanghai	Truck	110	
Shanghai-Hamburg	Boat	21068	0,01
Hamburg-Lemmer	Truck	372	
Lemmer-Gouda	Truck	151	
	Truck	633	0,01
<b>Total</b>			<b>0,02</b>

Disposal		Carbon footprint [kg CO2 equivalent]
Part	Weight [kg]	
Container	0,037	0,013542515
Handle	0,0164	-0,006578524
Sieve	0,013	-0,005214684
Tube holder	0,0038	-0,001524292
O-ring	0,0012	8,32779E-05
Tube	0,015466667	0,003375123
retrieval sticker	0,001	0,000366014
Bag	0,0078	-0,000209138
Front of retrieval sticker bag	0,00459	-0,000123068
Back of retrieval sticker bag	0,0054	-0,008822138
Label	0,001	-0,00163373
<b>Total</b>		<b>-0,006738647</b>
<b>Total</b>		<b>0,37</b>

Figure F.3.2: Alternative fossil-based material polyp trap

## F.3 Alternative polyp traps

### Bio-degradable polyp trap

Component	Material	Manufacturing processes(es)	Number of components	Weight [kg]	Total Weight [kg]
Container	Styrene-acrylonitrile (SAN)	Injection moulding	1	0,037	0,037
Handle	Polyhydroxyalkanoate (PHA)	Injection moulding	2	0,0082	0,0164
Sieve	Polyhydroxyalkanoate (PHA)	Injection moulding	2	0,0065	0,013
Tube holder	Polyhydroxyalkanoate (PHA)	Injection moulding	1	0,0038	0,0038
O-ring	Polyurethane (PU)	Injection moulding	2	0,0006	0,0012
Tube	Silicone	Blow moulding	1	0,015466667	0,015466667
retrieval sticker	PET	Injection moulding	1	0,001	0,001
Bag	LDPE		1	0,0078	0,0078
Front of retrieval sticker bag	LDPE		1	0,00459	0,00459
Back of retrieval sticker bag	Paper		1	0,0054	0,0054
Label	Paper		1	0,001	0,001
<b>Total</b>					<b>0,106656667</b>
<b>Total [1000 kg]</b>					<b>0,000106657</b>

### Shipping distance Shanghai-Hamburg

Distance km	References
20385	<a href="https://www.fluentcargo.com/routes/shanghai-cn/hamburg-de#:~:text=What%20is%20the%20distance%20between,%202C385%20Kilometres%20F%2012%2C667%20Miles">https://www.fluentcargo.com/routes/shanghai-cn/hamburg-de#:~:text=What%20is%20the%20distance%20between,%202C385%20Kilometres%20F%2012%2C667%20Miles</a> .
22551	<a href="http://ports.com/sea-route/port-of-shanghai,china/port-of-hamburg,germany/">http://ports.com/sea-route/port-of-shanghai,china/port-of-hamburg,germany/</a>
20268	<a href="https://app.searoutes.com/routing/search/core/DEHAM/CNSHA">https://app.searoutes.com/routing/search/core/DEHAM/CNSHA</a>
<b>21068</b>	

Carbon footprint [kg CO2 equivalent]	
<b>Total</b>	<b>0,36</b>
Material production	0,32
Manufacturing	0,10
Transport	0,02
Disposal	0,36
Styrene acrylonitrile (AS)	0,10952
Polyhydroxyalkanoate (PHA)	0,043797605
Polyhydroxyalkanoate (PHA)	0,04486584
Polyurethane (PU)	0,005231265
Silicone	0,113434552
PET	0,00219
LDPE	0,001190191
Paper	0,002642347

Eco-costs [€]	
<b>Total</b>	<b>0,00</b>
Human health	0,000
Eco toxicity	0,0000
Recourse scarcity	0
Carbon footprint	0,0000

Material production		Carbon footprint [kg CO2 equivalent]
Part	Weight [kg]	
Container	0,037	0,10952
Handle	0,0164	0,043797605
Sieve	0,013	0,034717614
Tube holder	0,0038	0,010148226
O-ring	0,0012	0,005231265
Tube	0,015466667	0,113434552
retrieval sticker	0,001	0,00219
Bag	0,0078	0,000749273
Front of retrieval sticker bag	0,00459	0,000440918
Back of retrieval sticker bag	0,0054	0,00222948
Label	0,001	0,000412867
<b>Total</b>		<b>0,32</b>

Manufacturing		Carbon footprint [kg CO2 equivalent]
Process	Weight [kg]	
Injection moulding	0,0724	0,087100732
Blow moulding	0,015466667	0,017507998
<b>Total</b>		<b>0,10</b>

Transport			Carbon footprint [kg CO2 equivalent]
From-to	Mode	Distance [km]	
Suzhou, Jiangsu-Shanghai	Truck	110	
Shanghai-Hamburg	Boat	21068	0,01
Hamburg-Lemmer	Truck	372	
Lemmer-Gouda	Truck	151	
	Truck	633	0,01
<b>Total</b>			<b>0,02</b>

Disposal		Carbon footprint [kg CO2 equivalent]
Part	Weight [kg]	
Container	0,037	-0,00100498
Handle	0,0164	-0,035769555
Sieve	0,013	-0,028353915
Tube holder	0,0038	-0,008288068
O-ring	0,0012	8,32779E-05
Tube	0,015466667	0,003375123
retrieval sticker	0,001	0,000366014
Bag	0,0078	-0,000209138
Front of retrieval sticker bag	0,00459	-0,000123069
Back of retrieval sticker bag	0,0054	-0,008822139
Label	0,001	-0,00163373
<b>Total</b>		<b>-0,080380179</b>
<b>Total</b>		<b>0,36</b>

Figure F.3.3: Bio-degradable polyp trap



## F.3 Alternative polyp traps

Endo-Safier bio-based

Component	Material	Manufacturing processes(es)	Number of components	Weight [kg]	Total Weight [kg]
Container	Styrene acrylonitrile (AS)	Injection moulding	1	0,037	0,037
Handle	bio-PE	Injection moulding	2	0,0082	0,0164
Sieve	bio-PE	Injection moulding	2	0,0065	0,013
Tube holder	bio-PE	Injection moulding	1	0,0038	0,0038
O-ring	Polyurethane (PU)	Injection moulding	2	0,0006	0,0012
Tube	Silicone	Blow moulding	1	0,015466667	0,015466667
retrieval sticker	PET	Injection moulding	1	0,001	0,001
Bag	LDPE		1	0,0078	0,0078
Front of retrieval sticker bag	LDPE		1	0,00459	0,00459
Back of retrieval sticker bag	Paper		1	0,0054	0,0054
Label	Paper		1	0,001	0,001
<b>Total</b>					<b>0,106656667</b>
<b>Total [1000 kg]</b>					<b>0,000106657</b>

Shipping distance Shanghai-Hamburg

Distance km	References
20385	<a href="https://www.fluentcargo.com/routes/shanghai-cn/hamburg-de#:~:text=What%20is%20the%20distance%20between,%202C385%20kilometres%20%2F%2012%20C667%20Miles.">https://www.fluentcargo.com/routes/shanghai-cn/hamburg-de#:~:text=What%20is%20the%20distance%20between,%202C385%20kilometres%20%2F%2012%20C667%20Miles.</a>
22551	<a href="http://ports.com/sea-route/port-of-shanghai,china/port-of-hamburg,germany/">http://ports.com/sea-route/port-of-shanghai,china/port-of-hamburg,germany/</a>
20268	<a href="https://app.searoutes.com/routing/search/core/DEHAM/CNSHA">https://app.searoutes.com/routing/search/core/DEHAM/CNSHA</a>
<b>21068</b>	

	Carbon footprint [kg CO2 equivalent]
<b>Total</b>	<b>0,29</b>
Material production	0,30
Manufacturing	0,10
Transport	0,02
Disposal	0,29
Styrene acrylonitrile (AS)	0,10952
bio-PE	0,030668
bio-PE	0,031416
Polyurethane (PU)	0,005231265
Silicone	0,113434552
PET	0,00219
LDPE	0,001190191
Paper	0,002642347

	Eco-costs [€]
<b>Total</b>	<b>0,00</b>
Human health	0,000
Eco toxicity	0,0000
Recourse scarcity	0
Carbon footprint	0,0000



Figure F.3.4: Bio-based polyp trap

Material production		Carbon footprint [kg CO2 equivalent]
Part	Weight [kg]	
Container	0,037	0,10952
Handle	0,0164	0,030668
Sieve	0,013	0,02431
Tube holder	0,0038	0,007106
O-ring	0,0012	0,005231265
Tube	0,015466667	0,113434552
retrieval sticker	0,001	0,00219
Bag	0,0078	0,000749273
Front of retrieval sticker b	0,00459	0,000440918
Back of retrieval sticker b:	0,0054	0,00222948
Label	0,001	0,000412867
<b>Total</b>		<b>0,30</b>

Manufacturing		Carbon footprint [kg CO2 equivalent]
Process	Weight [kg]	
Injection moulding	0,0724	0,087100732
Blow moulding	0,015466667	0,017507998
<b>Total</b>		<b>0,10</b>

Transport			Carbon footprint [kg CO2 equivalent]
From-to	Mode	Distance [km]	
Suzhou, Jiangsu-Shanghai	Truck	110	
Shanghai-Hamburg	Boat	21068	0,01
Hamburg-Lemmer	Truck	372	
Lemmer-Gouda	Truck	151	
	Truck	633	0,01
<b>Total</b>			<b>0,02</b>

Disposal		Carbon footprint [kg CO2 equivalent]
Part	Weight [kg]	
Container	0,037	-0,00100498
Handle	0,0164	-0,060658637
Sieve	0,013	-0,048083066
Tube holder	0,0038	-0,01405505
O-ring	0,0012	8,32779E-05
Tube	0,015466667	0,003375123
retrieval sticker	0,001	0,000366014
Bag	0,0078	-0,000209138
Front of retrieval sticker b	0,00459	-0,000123069
Back of retrieval sticker b:	0,0054	-0,008822139
Label	0,001	-0,00163373
<b>Total</b>		<b>-0,130765395</b>
<b>Total</b>		<b>0,29</b>

## F.3 Alternative polyp traps

Mechanically recycled polyp trap

Component	Material	Manufacturing processes	Number of components	Weight [kg]	Total Weight [kg]
Container	PET	Injection moulding	1	0,037	0,037
Handle	Polyethylene (PE)	Injection moulding	2	0,0082	0,0164
Sieve	Polyethylene (PE)	Injection moulding	2	0,0065	0,013
Tube holder	Polyethylene (PE)	Injection moulding	1	0,0038	0,0038
O-ring	Polyurethane (PU)	Injection moulding	2	0,0006	0,0012
Tube	Silicone	Blow moulding	1	0,015466667	0,015466667
retrieval sticker	PET	Injection moulding	1	0,001	0,001
Bag	LDPE		1	0,0078	0,0078
Front of retrieval sticker	LDPE		1	0,00459	0,00459
Back of retrieval sticker	Paper		1	0,0054	0,0054
Label	Paper		1	0,001	0,001
<b>Total</b>					<b>0,106656667</b>
<b>Total [1000 kg]</b>					<b>0,000106667</b>

Shipping distance Shanghai-Hamburg

Distance km	References
20385	<a href="https://www.fluentcargo.com/routes/shanghai-cn/hamburg-de#:~:text=What%20is%20the%20distance%20between,%202C385%20Kilometres%202F%2012%2C667%20MI">https://www.fluentcargo.com/routes/shanghai-cn/hamburg-de#:~:text=What%20is%20the%20distance%20between,%202C385%20Kilometres%202F%2012%2C667%20MI</a>
22551	<a href="http://ports.com/sea-route/port-of-shanghai,china/port-of-hamburg,germany/">http://ports.com/sea-route/port-of-shanghai,china/port-of-hamburg,germany/</a>
20268	<a href="https://app.searoutes.com/routing/search/core/DEHAM/CNSHA">https://app.searoutes.com/routing/search/core/DEHAM/CNSHA</a>
<b>21068</b>	

Carbon footprint [kg CO <sub>2</sub> equivalent]	
Total	0,24
Material production	0,16
Manufacturing	0,10
Transport	0,02
Disposal	0,24
Styrene acrylonitrile (SAN)	0,020957351
Polyethylene (PE)	0,009289204
Polyethylene (PE)	0,00951577
Polyurethane (PU)	0,005231265
Silicone	0,113434552
PET	0,00219
LDPE	0,001190191
Paper	0,002642347

Eco-costs [€]	
Total	0,00
Human health	0,000
Eco toxicity	0,0000
Recourse scarcity	0
Carbon footprint	0,0000



Material production		Carbon footprint [kg CO <sub>2</sub> equivalent]
Part	Weight [kg]	
Container	0,037	0,020957351
Handle	0,0164	0,009289204
Sieve	0,013	0,007363394
Tube holder	0,0038	0,002152377
O-ring	0,0012	0,005231265
Tube	0,015466667	0,113434552
retrieval sticker	0,001	0,00219
Bag	0,0078	0,000749273
Front of retrieval sticker bag	0,00459	0,000440918
Back of retrieval sticker bag	0,0054	0,00222948
Label	0,001	0,000412867
<b>Total</b>		<b>0,16</b>

Manufacturing		Carbon footprint [kg CO <sub>2</sub> equivalent]
Process	Weight [kg]	
Injection moulding	0,0724	0,087100732
Blow moulding	0,015466667	0,017507998
<b>Total</b>		<b>0,10</b>

Transport			Carbon footprint [kg CO <sub>2</sub> equivalent]
From-to	Mode	Distance [km]	
Suzhou, Jiangsu-Shanghai	Truck	110	
Shanghai-Hamburg	Boat	21068	0,01
Hamburg-Lemmer	Truck	372	
Lemmer-Gouda	Truck	151	
	Truck	633	0,01
<b>Total</b>			<b>0,02</b>

Disposal		Carbon footprint [kg CO <sub>2</sub> equivalent]
Part	Weight [kg]	
Container	0,037	-0,020671802
Handle	0,0164	-0,009162637
Sieve	0,013	-0,007263066
Tube holder	0,0038	-0,00212305
O-ring	0,0012	8,32779E-05
Tube	0,015466667	0,003375123
retrieval sticker	0,001	0,000366014
Bag	0,0078	-0,000209138
Front of retrieval sticker bag	0,00459	-0,000123069
Back of retrieval sticker bag	0,0054	-0,008822139
Label	0,001	-0,00163373
<b>Total</b>		<b>-0,046184216</b>
<b>Total</b>		<b>0,24</b>

Figure F.3.3: Mechanically recycled polyp trap

### F.3 Alternative polyp traps

#### Polyp trap with reusable container

Component	Material	Manufacturing processes(es)	Number of components	Weight [kg]	Total Weight [kg]
Container	Styrene acrylonitrile (AS)	Injection moulding	1	0,037	0,037
Handle	Polycarbonate (PC)	Injection moulding	2	0,0082	0,0164
Sieve	Polyethylene (PE)	Injection moulding	2	0,0065	0,013
Tube holder	Polyethylene (PE)	Injection moulding	1	0,0038	0,0038
O-ring	Polyurethane (PU)	Injection moulding	2	0,0006	0,0012
Tube	Silicone	Blow moulding	1	0,015466667	0,015466667
retrieval sticker	PET	Injection moulding	1	0,001	0,001
Bag	LDPE		1	0,0078	0,0078
Front of retrieval sticker bag	LDPE		1	0,00459	0,00459
Back of retrieval sticker bag	Paper		1	0,0054	0,0054
Label	Paper		1	0,001	0,001
<b>Total</b>					<b>0,106656667</b>
<b>Total [1000 kg]</b>					<b>0,000106657</b>

#### Shipping distance Shanghai-Hamburg

Distance km	References
20385	<a href="https://www.fluentcargo.com/routes/shanghai-cn/hamburg-de#:~:text=What%20is%20the%20distance%20between,20%2C385%20Kilometres%20%2F%2012%2C667%20Miles">https://www.fluentcargo.com/routes/shanghai-cn/hamburg-de#:~:text=What%20is%20the%20distance%20between,20%2C385%20Kilometres%20%2F%2012%2C667%20Miles</a>
22551	<a href="http://ports.com/sea-route/port-of-shanghai,china/port-of-hamburg,germany/">http://ports.com/sea-route/port-of-shanghai,china/port-of-hamburg,germany/</a>
20268	<a href="https://app.searoutes.com/routing/search/core/DEHAM/CNSHA">https://app.searoutes.com/routing/search/core/DEHAM/CNSHA</a>
<b>21068</b>	

	Carbon footprint [kg CO2 equivalent]
<b>Total</b>	<b>0,43</b>
Material production	0,32
Manufacturing	0,10
Transport	0,02
Disposal	-0,01
Styrene acrylonitrile (AS)	0,10952
Polycarbonate (PC)	0,05576
Polyethylene (PE)	0,03024
Polyurethane (PU)	0,005231265
Silicone	0,113434552
PET	0,00219
LDPE	0,001190191
Paper	0,002642347
Supplementary set	0,13
<b>Eco-costs [€]</b>	
<b>Total</b>	<b>0,13</b>
Human health	0,000
Eco toxicity	0,0000
Recourse scarcity	0
Carbon footprint	0,0000

	Base set	Supplementary set
<b>Material production</b>	<b>Carbon footprint [kg CO2 equivalent]</b>	<b>Carbon footprint [kg CO2 equivalent]</b>
<b>Part</b>	<b>Weight [kg]</b>	
Container	0,037	0,10952
Handle	0,0164	0,05576
Sieve	0,013	0,0234
Tube holder	0,0038	0,00684
O-ring	0,0012	0,005231265
Tube	0,015466667	0,113434552
retrieval sticker	0,001	0,00219
Bag	0,0078	0,000749273
Front of retrieval sticker bag	0,00459	0,000440918
Back of retrieval sticker bag	0,0054	0,00222948
Label	0,001	0,000412867
<b>Total</b>	<b>0,32</b>	<b>0,09</b>
<b>Manufacturing</b>	<b>Carbon footprint [kg CO2 equivalent]</b>	<b>Carbon footprint [kg CO2 equivalent]</b>
<b>Process</b>	<b>Weight [kg]</b>	
Injection moulding	0,0724	0,087100732
Blow moulding	0,015466667	0,017507998
<b>Total</b>	<b>0,10</b>	<b>0,04</b>
<b>Transport</b>	<b>Carbon footprint [kg CO2 equivalent]</b>	<b>Carbon footprint [kg CO2 equivalent]</b>
<b>From-to</b>	<b>Mode</b>	<b>Distance [km]</b>
Suzhou, Jiangsu-Shanghai	Truck	110
Shanghai-Hamburg	Boat	21068
Hamburg-Lemmer	Truck	372
Lemmer-Gouda	Truck	151
	Truck	633
		0,01
		0,01
<b>Disposal</b>	<b>Carbon footprint [kg CO2 equivalent]</b>	<b>Carbon footprint [kg CO2 equivalent]</b>
<b>Part</b>	<b>Weight [kg]</b>	
Container	0,037	-0,00100498
Handle	0,0164	0,007278221
Sieve	0,013	-0,007263066
Tube holder	0,0038	-0,00212305
O-ring	0,0012	8,32779E-05
Tube	0,015466667	0,003375123
retrieval sticker	0,001	0,000366014
Bag	0,0078	-0,000209138
Front of retrieval sticker bag	0,00459	-0,000123069
Back of retrieval sticker bag	0,0054	-0,008822139
Label	0,001	-0,00163373
<b>Total</b>	<b>-0,010076536</b>	<b>-0,010323629</b>
<b>Total</b>	<b>0,43</b>	<b>0,13</b>

Figure F.3.3: Polyp trap with reusable container



## F.4 LCAs of concepts

Minimized concept - Fossil/bio based

Component	Material	Manufacturing pro umber of compon	Weight [kg]	Weight [kg]
Window	Styrene acrylonitrile (AS)	Injection moulding	1 0,00223	0,00223
Container	Polyhydroxalkanoate (PHA)	Injection moulding	1 0,00792	0,00792
Drawer	Polyhydroxalkanoate (PHA)	Injection moulding	2 0,00597	0,01194
Gasket	Polyurethane (PU)	Injection moulding	1 0,00003	0,00003
Tube	Silicone	Blow moulding	1 0,007733	0,007733333
Bag	LDPE		1 0,0078	0,0078
Label	Paper		1 0,001	0,001
<b>Total</b>				<b>0,038653333</b>
<b>Total [1000 kg]</b>				<b>3,86533E-05</b>

Carbon footprint [kg CO2 equivalent]	
Total	0,11
Material production	0,12
Manufacturing	0,04
Transport	0,00
Disposal	-0,04

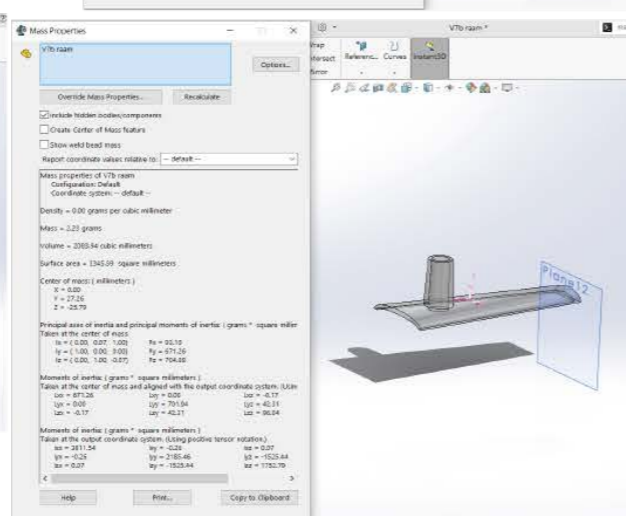
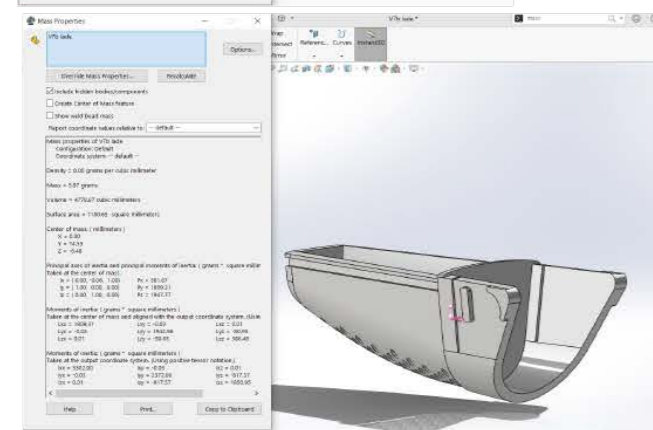
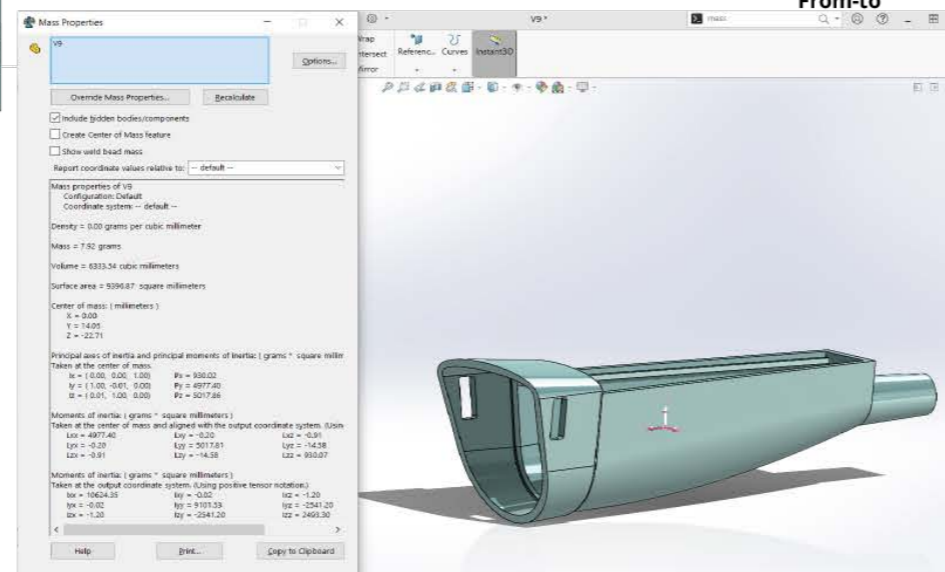
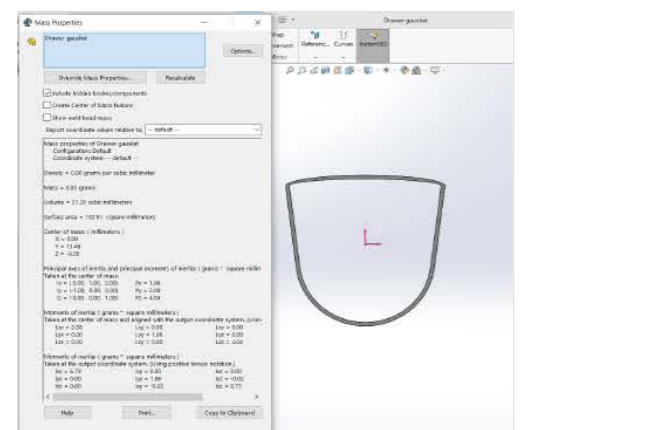

Material production	Carbon footprint [kg CO2 equivalent]
---------------------	--------------------------------------

Part	Weight [kg]	Carbon footprint [kg CO2 equivalent]
Window	0,00223	0,0066008
Container	0,00792	0,021151039
Drawer	0,01194	0,031886793
Gasket	0,00003	0,000130782
Tube	0,007733333	0,056717276
Bag	0,0078	0,000749273
Label	0,001	0,000412867
<b>Total</b>		<b>0,12</b>

Manufacturing	Carbon footprint [kg CO2 equivalent]
---------------	--------------------------------------

Process	Weight [kg]	Carbon footprint [kg CO2 equivalent]
Injection moulding	0,02212	0,026611439
Blow moulding	0,007733333	0,008753999
<b>Total</b>		<b>0,04</b>

Transport	Carbon footprint [kg CO2 equivalent]
-----------	--------------------------------------

From-to	Mode	Distance [km]	Carbon footprint [kg CO2 equivalent]
---------	------	---------------	--------------------------------------

Truck		120	
Truck		151	
Truck		271	0,00
<b>Total</b>			<b>0,00</b>
<b>Carbon footprint [kg CO2 equivalent]</b>			<b>0,0905</b>

Weight [kg]	Carbon footprint [kg CO2 equivalent]
-------------	--------------------------------------

0,00223	-6,05704E-05
0,00792	-0,017274078
0,01194	-0,2181070407
0,00003	-2,181070407
0,007733333	0,069398285
0,0078	0,218219146
0,001	-0,02681252
	-1,633729512
<b>Total</b>	<b>-0,043529853</b>
<b>Total</b>	<b>0,11</b>

Carbon footprint [kg CO2 equivalent]
--------------------------------------

2,96
2,670585691
2,670585691
4,359387398
7,334130488
0,096060634
0,41286674

Carbon footprint [kg CO2 equivalent]
--------------------------------------

1,20304878
1,131982602

Carbon footprint [kg CO2 equivalent]
--------------------------------------

Carbon footprint [kg CO2 equivalent]
--------------------------------------

Carbon footprint [kg CO2 equivalent]
--------------------------------------

Carbon footprint [kg CO2 equivalent]
--------------------------------------

Carbon footprint [kg CO2 equivalent]
--------------------------------------

Carbon footprint [kg CO2 equivalent]
--------------------------------------

Carbon footprint [kg CO2 equivalent]
--------------------------------------

Carbon footprint [kg CO2 equivalent]
--------------------------------------

Carbon footprint [kg CO2 equivalent]
--------------------------------------

Carbon footprint [kg CO2 equivalent]
--------------------------------------

Carbon footprint [kg CO2 equivalent]
--------------------------------------

Carbon footprint [kg CO2 equivalent]
--------------------------------------

Carbon footprint [kg CO2 equivalent]
--------------------------------------

Carbon footprint [kg CO2 equivalent]
--------------------------------------

Carbon footprint [kg CO2 equivalent]
--------------------------------------

Carbon footprint [kg CO2 equivalent]
--------------------------------------

Figure F.4.1: Rethink concept, fossil / bio-based

## F.4 LCAs of concepts

Minimized concept - Fossil based

Component	Material	Manufacturing proumber of componen	Weight [kg]	tal Weight [kg]
Window	Styrene acrylonitrile (AS)	Injection moulding	1	0,00223
Container	Polyethylene (PE)	Injection moulding	1	0,00603
Drawer	Polyethylene (PE)	Injection moulding	2	0,00455
Gasket	Polyurethane (PU)	Injection moulding	1	0,00003
Tube	Silicone	Blow moulding	1	0,00773333
Bag	LDPE		1	0,0078
Label	Paper		1	0,001
<b>Total</b>				<b>0,033923333</b>
<b>Total [1000 kg]</b>				<b>3,39233E-05</b>

	Carbon footprint [kg CO <sub>2</sub> equivalent]
Total	0,11
Material production	0,09
Manufacturing	0,03
Transport	0,00
Disposal	0,11

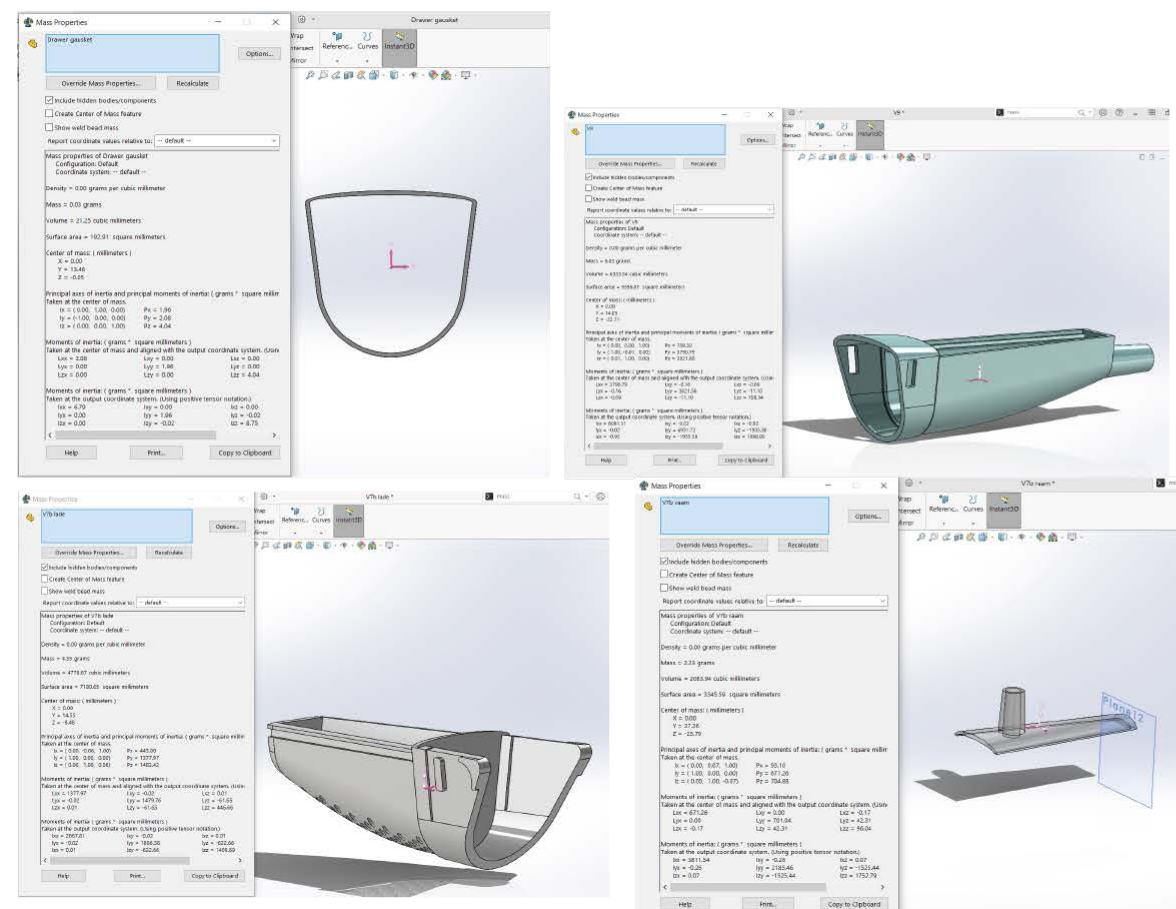

Figure F.4.2: Rethink concept, fossil-based

Material production	Carbon footprint [kg CO <sub>2</sub> equivalent]
<b>Part</b>	<b>Weight [kg]</b>
Window	0,00223
Container	0,00603
Drawer	0,0091
Gasket	0,00003
Tube	0,00773333
Bag	0,0078
Label	0,001
<b>Total</b>	<b>0,09</b>

Manufacturing	Carbon footprint [kg CO <sub>2</sub> equivalent]
<b>Process</b>	<b>Weight [kg]</b>
Injection moulding	0,01739
Blow moulding	0,00773333
<b>Total</b>	<b>0,03</b>

Transport	Carbon footprint [kg CO <sub>2</sub> equivalent]		
<b>From-to</b>	<b>Mode</b>	<b>Distance [km]</b>	
Emmen-Lemmer	Truck	120	
Lemmer-Gouda	Truck	151	
	<b>Truck</b>	<b>271</b>	<b>0,00</b>
			<b>0,00</b>

Disposal	Carbon footprint [kg CO <sub>2</sub> equivalent]
<b>Part</b>	<b>Weight [kg]</b>
Window	0,00223
Container	0,00603
Drawer	0,0091
Gasket	0,00003
Tube	0,00773333
Bag	0,0078
Label	0,001
<b>Total</b>	<b>-0,008666885</b>
<b>Total</b>	<b>0,11</b>



## F.4 LCAs of concepts

Re-use concept - Fossil/bio based

Component	Material	Manufacturing processes(es)	Number of components	Weight [kg]	Total Weight [kg]
Window	Polyhydroxyalkanoate (PHA)	Injection moulding	1	0,00288	0,00288
Drawer	Polyhydroxyalkanoate (PHA)	Injection moulding	2	0,00597	0,01194
Tube	Silicone	Blow moulding	1	0,007733333	0,007733333
Bag	LDPE	-	1	0,0078	0,0078
Label	Paper	-	1	0,001	0,001
<b>Total</b>					<b>0,031353333</b>
<b>Total [1000 kg]</b>					<b>3,13533E-05</b>

	Carbon footprint [kg CO2 equivalent]
Total	0,08
Material production	0,10
Manufacturing	0,03
Transport	0,00
Disposal	-0,05

Material production		Carbon footprint [kg CO2 equivalent]
Part	Weight [kg]	
Window	0,00288	0,007691287
Drawer	0,01194	0,031886793
Tube	0,007733333	0,056717276
Bag	0,0078	0,000749273
Label	0,001	0,000412867
<b>Total</b>		<b>0,10</b>

Manufacturing		Carbon footprint [kg CO2 equivalent]
Process	Weight [kg]	
Injection moulding	0,01482	0,017829183
Blow moulding	0,007733333	0,008753999
<b>Total</b>		<b>0,03</b>

Transport			Carbon footprint [kg CO2 equivalent]
From-to	Mode	Distance [km]	
Emmen-Lemmer	Truck	120	
Lemmer-Gouda	Truck	151	
	<b>Truck</b>	<b>271</b>	<b>0,00</b>
			<b>0,00</b>

Disposal		Carbon footprint [kg CO2 equivalent]
Part	Weight [kg]	
Window	0,00288	-0,006281483
Drawer	0,01194	-0,026041981
Tube	0,007733333	-0,00020735
Bag	0,0078	-0,01274309
<b>Total</b>		<b>-0,045273904</b>
<b>Total</b>		<b>0,08</b>

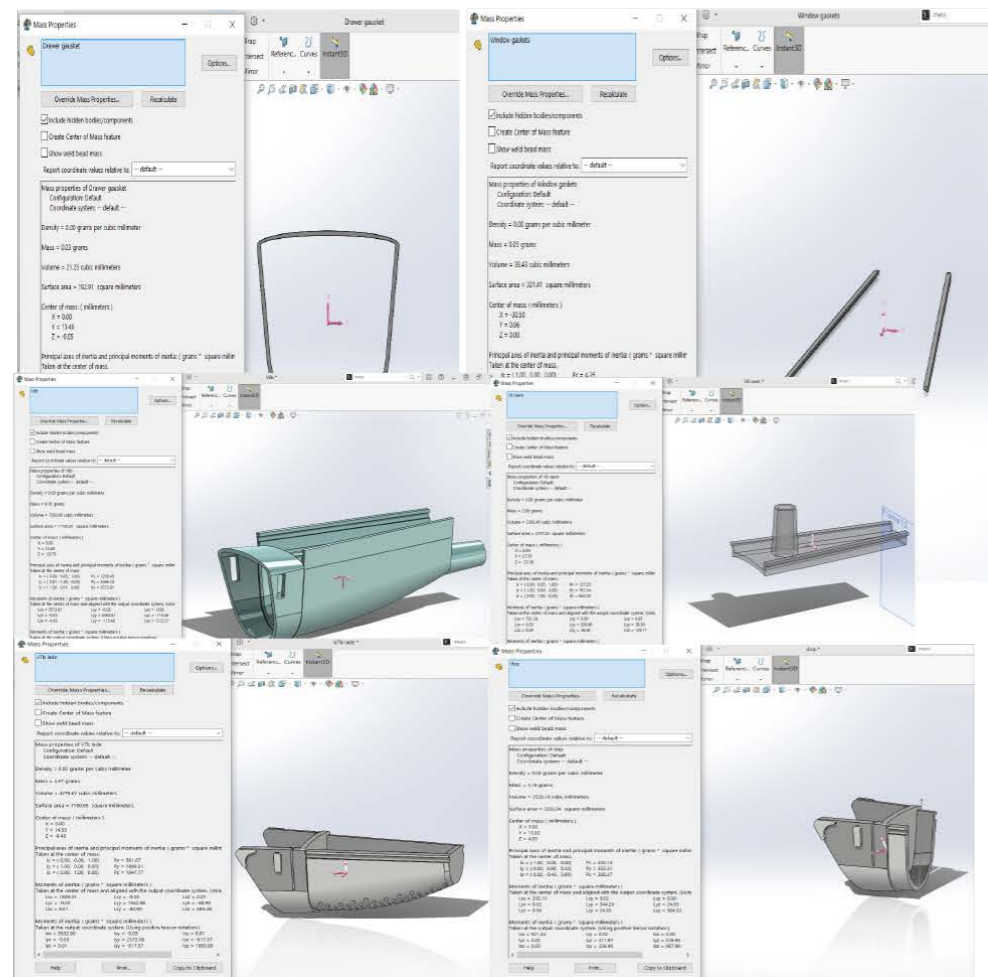

Figure F.4.3 Reuse concept supplementary set.



## F.5 LCA results

Product	Average annual number	National annual waste generation [kg]	National annual CF [kg CO2 equivalent]
Polyp traps high estimation	132272	24197,83968	11666699953
Polyp traps low estimation	96419	17638,89186	8504381447
Polyp trap	114.346	20918,36577	88.202,34
Formalin cup (traditional use)	396.793	25052,86192	15321,96854
Formalin cups (decreased use)	396793	18314,81683	14987,53315
formalin cups 50 mL	99198,25	6263,215481	6263,215481
formalin cups 30 mL	297594,75	12051,60134	8724,317668
Error margin (numbers)	35.853	6558,94782	3162318506
Error margin (percentage)	15,67748622	15,67748622	1792650

Figure F.5.1 LCA results of annual impact.

Eco-costs [€]	Endo-Safier	Steris eTrap	ThomasTrap	Average polyp trap
Total eco-costs	16.720,53	15.838,45	60.331,38	30.963,45
Recourse scarcity	8001,940247	7627,454638	33139,1485	16256,18113
Carbon footprint	6069,978864	6150,214718	20326,46998	10848,88785
Eco toxicity	0,012256309	1322,008881	3694,643246	1672,221461
Human health	377,7303274	479,485086	830,7814157	562,6656097

Figure F.5.2 LCA results in eco-costs.

### Average daily use of polyp traps

5,4

Type of polyp trap	Number of products	Weight [kg]	Carbon footprint [kg CO2 equivalent]
Average polyp trap	114.346	20918,36577	88.202,34
Reusable polyp trap   Basic kit	21175,09259	1110,139521	3872,937199
Reusable polyp trap   Supplementary kit	93170,40741	2200,685023	2327,622197
Reusable polyp trap	114345,5	3310,824544	6200,559396
Minimized polyp trap (fossil based)	114.346	4763,252378	4763,252378
Minimized polyp trap (bio-based & bio-degradable)	114.346	5304,106593	5304,106593

Figure F.5.3: LCA results daily use.

## F.5. LCA results

Carbon footprint [kg CO2 equivalent]	Endo-Safier	Steris eTrap	ThomasTrap	Average
Total	49.349,42	50.001,75	165.255,85	88.202,34
Material production	36.614,38	37.802,75	116.351,24	63.589,46
Manufacturing	11.961,54	10.164,93	46.564,71	22.897,06
Transport	1.925,71	677,0427118	5.235,31	2.612,69
Disposal	-1.152,21	1357,022368	-2.895,42	-896,87
Styrene acrylonitrile (AS)	0,10952	0,099456	0,840936	
Polycarbonate (PC)	0,05576	0	0	
Polyethylene (PE)	0,03024	0	0,05388	
Stainless steel	0	0	0,006812632	
Polyurethane (PU)	0,005231265	0,077742409	0,009590652	
Silicone	0,113434552	0,090209805	0,081653319	
PET	0,00219	0,06278	0,0225497	
LDPE	0,001190191	0	0,000313158	
Paper	0,002642347	0,000412867	0,001805604	

Figure F.5.4 LCA results of processes and materials in CF and weight

	Weight [kg]	Carbon footprint [kg CO2 equivalent]
Endo-Safier	0,106656667	49.349,42
Steris eTrap	0,0934	50.001,75
ThomasTrap	0,348763333	165.255,85
Average polyp trap	0,18294	88.202,34
50 mL formalin cup	0,063138367	0,04
30 mL formalin cup	0,040496687	0,03
Minimized polyp trap (bio-based & bio-degradab)	0,046386667	0,18
Minimized polyp trap (fossil based)	0,041656667	0,18
Reusable polyp trap   Basic kit	0,052426667	0,18
Reusable polyp trap   Supplementary kit	0,02362	0,02
Thin walled polyp trap	-	29.661,28
Alternative fossil based plastic polyp trap	-	42.827,60
Bio-degradable polyp trap	-	41.615,07
Bio-based polyp trap	-	32.814,51
Chemically recycled plastic polyp trap	-	56.143,02
Mechanically recycled plastic polyp trap	-	27.410,48
Partly reusable polyp trap	-	21.349,81
Reprocessed polyp trap (10 use cycles)	-	15077,00057
Reprocessing of polyp traps	-	6256,766544
Reusable container set	-	9.138,78
Supplementary set reusable container	-	12.211,03

Figure F.5.5 LCA results of various alternative polyp traps

Reprocessing resources	CF per kg CO2 equivalent/[kg required resources [kg] [MJ]	Carbon footprint [kg CO2 equivalent]
Water [kg]	0,000635069	0,002089441
Electricity [MJ]	0,13290061	0,052628641
<b>Total</b>		<b>0,054718083</b>

Figure F.5.6 Reprocessing resources

**Cost price production minimized concept | Fossil based**

Manufactured parts

Components	Material	Weight	Material price [€]	Manufacturing price [€]
Container	PE	0,006633	0,007685436	0,341354311
Window	SAN	0,002453	0,00523462	0,27161372
Drawer (2x)	PE	0,01001	0,011598253	0,447981176
Gasket	PU	0,000033	0,0000825	0,122042783
<b>Total price [€]</b>			<b>0,02460081</b>	<b>1,182991989</b>

Purchased parts

Components	Price [€]
Tube	0,242688
Bag	0,01901
Label	0,114669142
	<b>0,376367142</b>

Total Cost price

	<b>1,90075193</b>
--	-------------------

Revenu at €6 [€]	4,09924807
Revenu at €10 [€]	8,09924807
Annual evenu at €6 [€]	196003,6813
Annual revenue at €10	387261,8613
Average	291632,7713

**Cost price production minimized concept | Bio based**

Manufactured parts

Components	Material	Weight	Material price [€]	Manufacturing price without tooling costs[€]	Manufacturing price [€]
Container	PHA	0,008712	0,0344124	0,265367228	0,333668875
Window	SAN	0,002453	0,00523462	0,168899672	0,266379099
Drawer (2x)	PHA	0,013134	0,0518793	0,282834128	0,436382922
Gasket	PU	0,000033	0,0000825	0,019328736	0,121960283
<b>Total price</b>			<b>0,09160882</b>	<b>0,736429763</b>	<b>1,25</b>

Purchased parts

Components	Price [€]
Tube	0,242688
Bag	0,01901
Label	0,114669142
	<b>0,376367142</b>

	<b>1,951640571</b>
--	--------------------

Revenu at €6 [€]	4,048359429
Revenu at €10 [€]	8,048359429
Annual evenu at €6 [€]	193570,4641
Annual revenue at €10	384828,6441
Average	289199,5541
Error margin	95629,09

**Cost price production reuse concept | Base kit**

Manufactured parts

Components	Material	Weight	Material price [€]	Manufacturing price [€]
Container	PHA	0,01001	0,0395395	1,349870117
Window	PHA	0,003168	0,0125136	0,544609688
Drawer (2x)	PHA	0,013134	0,0518793	0,829006129
Lid	PHA	0,003476	0,0137302	0,726292082
Drawer gasket	PU	0,000033	0,0000825	0,20664372
Window gasket	PU	0,000055	0,0001375	0,20664372
<b>Total price</b>			<b>0,1178826</b>	<b>3,863065456</b>

Purchased parts

Components	Price [€]
Tube	0,242688
Bag	0,01901
Label	0,114669142
	<b>0,376367142</b>

	<b>5,228778238</b>
--	--------------------

Revenu at €6 [€]	0,771221762
Revenu at €10 [€]	4,771221762
Annual evenu at €6 [€]	6828,818084
Annual revenue at €10	42246,99957
Average	24537,90882
Error margin	17709,09074

**Cost price production reuse concept | Supplementary kit**

Manufactured parts

Components	Material	Weight	Material price [€]	Manufacturing price [€]
Window	PHA	0,003168	0,0125136	0,203144875
Drawer (2x)	PHA	0,013134	0,0518793	0,347150375
<b>Total price</b>			<b>0,0643929</b>	<b>0,55029525</b>

Purchased parts

Components	Price [€]
Tube	0,242688
Bag	0,01901
Label	0,114669142
	<b>0,376367142</b>

	<b>1,189266351</b>
--	--------------------

Revenu at €6 [€]	4,810733649
Revenu at €10 [€]	8,810733649
Annual evenu at €6 [€]	187426,1812
Annual revenue at €10	343266,1797
Average	265346,1804
Error margin	77919,99926

0,1822755

**Price of materials**

Polyethylene	unit [kg]	price[€/kg]	Rerefence
	1112	1000	1,112 <a href="https://www.statista.com/statistics/1171074/price-high-density-polyethylene-forecast-globally/#:~:text=The%20price%20of%20high%2Ddensity,per%20metric%20ton%20in%202018">https://www.statista.com/statistics/1171074/price-high-density-polyethylene-forecast-globally/#:~:text=The%20price%20of%20high%2Ddensity,per%20metric%20ton%20in%202018</a>
	1.279	1000	1,279 <a href="https://www.chemanalyst.com/Pricing-data/hdpe-7">https://www.chemanalyst.com/Pricing-data/hdpe-7</a>
	1085	1000	1,085 <a href="https://www.plasticportal.eu/en/cenove-repoty?year=2019&amp;week=26">https://www.plasticportal.eu/en/cenove-repoty?year=2019&amp;week=26</a>
<b>Average price</b>			<b>1,158666667</b>
<b>SAN</b>			
	2.856,36	1000	2,85636 <a href="https://www.chemanalyst.com/Pricing-data/styrene-acrylonitrile-1104">https://www.chemanalyst.com/Pricing-data/styrene-acrylonitrile-1104</a>
	1725,54	1000	1,72554 <a href="https://www.intratec.us/chemical-markets/styrene-acrylonitrile-resin-price">https://www.intratec.us/chemical-markets/styrene-acrylonitrile-resin-price</a>
	1820	1000	1,82 <a href="https://businessanalytiq.com/procurementanalytics/index/styrene-acrylonitrile-resin-san-price-index/">https://businessanalytiq.com/procurementanalytics/index/styrene-acrylonitrile-resin-san-price-index/</a>
			<b>2,133966667</b>
<b>PU</b>			
	2.500	1000	2,5 <a href="https://www.chemanalyst.com/Pricing-data/polyurethane-pu-resin-1150">https://www.chemanalyst.com/Pricing-data/polyurethane-pu-resin-1150</a>
			<b>2,5</b>
<b>PHA</b>			
			<b>3,95 <a href="https://www.mdpi.com/2073-444">https://www.mdpi.com/2073-444</a></b>

Error margin accounting for transport and assembly	1,2
Revenu margin	1,5
Sprue margin	1,1

Total reuse concept

Annual evenu at €6 [€]	194254,9993
Annual revenue at €10	385513,1793
Average	289884,0893
Error margin	95629,09

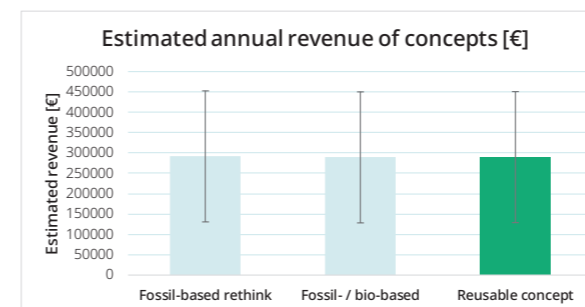

Estimation of annual revenue [€]

Fossil-based rethink conc	291632,7713
Fossil- / bio-based rethin	289199,5541
Reusable concept	289884,0893
Error margin	160963,6504

Estimation of cost price per polypectomy [€]

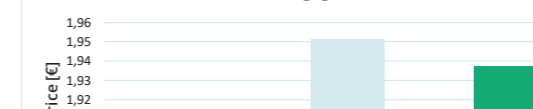

Estimatio of cost price [€] Per day Per polypectomy [€]

Fossil-based rethink conc	10,26406042	1,90075193
Fossil- / bio-based rethin	10,53885908	1,951640571
Reusable concept	10,46155018	1,937324108



# G. Interview questions

## G.1 Interview questions nurses

- Wat vind je van de twee ideerichtingen (hergebruik / optimalisatie). Heb je een voorkeur voor één van de twee?  
Hergebruik
- Wat vind je van de ideeën voor hergebruik?
  - Welke (combinatie) zou misschien kunnen werken?
- Hoe realistisch denk je dat een gedeeltelijk herbruikbaar poliep opvangbakje is?
- Zie je het doorspoelen en droogblazen als een mogelijkheid om hygiëne risico's te beperken?
  - Zou dit als een extra taak voelen?
- Zou jou voorkeur naar een herbruikbaar of wegwerp bakje gaan?
  - Welke voor en nadelen zitten er volgens jou aan het hergebruik?
  - Als er een extra handeling nodig is om een bakje te hergebruiken, zoals het aansluiten van het raam, zou dit er dan voor zorgen dat je voorkeur verandert?
  - Zou je hergebruik als minder hygiënisch ervaren?
  - Zou je hergebruik als meer werk ervaren?
  - Welke collega's hebben mogelijk een sterke voorkeur voor, of tegen een herbruikbaar opvangbakje?
    - Welke bezwaren zouden zij hebben tegen hergebruik van het bakje?
- Denk je dat, met één of meer van deze aanpassingen het risico op residu weefsel voldoende verlaagd kan worden kan worden?
- Denk je dat, met één of meer van deze aanpassingen het risico op infecties voldoende verlaagd kan worden kan worden?
- Zijn er nog andere risico's die bij hergebruik komen kijken?
- Heb je zelf nog ideeën om het hergebruik van het poliep opvangbakje mogelijk te maken.
- Is één dag een logische tijdsspanne voor hergebruik van het poliep opvangbakje?  
Optimalisatie
- Hoe beïnvloed een kleinere maat van de container de functie en het gebruik van het

- poliep opvangbakje?
  - Hoe beïnvloed een kleinere maat van de container de betrouwbaarheid en van het poliep opvangbakje?
    - Zou de kleinere container kunnen leiden tot overstroming van het bakje en spatgevaar?
  - Hoe beïnvloed een kleinere maat van de lade de functie en het gebruik van het poliep opvangbakje?
  - Hoe beïnvloed een kleinere maat van de lade de betrouwbaarheid en van het poliep opvangbakje?
    - Zou een outlet aan de zijkant een lekrisico kunnen veroorzaken?
    - Zou een outlet aan de zijkant consequenties hebben voor je gevoel van hygiëne en veiligheid tijdens het gebruik?
  - Welke vorm/grootte heeft je voorkeur?
    - Welke absoluut niet?
  - Zie je nog risico's of obstakels die ik over het hoofd heb gezien?
  - Zie je nog mogelijkheden of heb je ideeën voor aanpassingen?
  - Welke belanghebbenden zou ik volgens jou nog moeten spreken?

## G.2 Interview questions infection prevention & Sterile Medical Devices

- Wat is je precieze functie binnen het ziekenhuis?
- Wat vind je van de twee ideerichtingen (hergebruik / optimalisatie). Heb je een voorkeur voor één van de twee?  
Hergebruik
- Wat vind je van de ideeën voor hergebruik?
  - Welke (combinatie) zou misschien kunnen werken?
- Hoe realistisch denk je dat een gedeeltelijk herbruikbaar poliep opvangbakje is?
- Zie je het doorspoelen en droogblazen als een mogelijkheid om hygiëne risico's te beperken?
  - Omdat de verplegers het bakje aanraken met vieze handen, zou het bakje na waarschijnlijk na elke patiënt moeten afnemen, om infectie verspreiding te voorkomen.
    - Zou dit voldoende mitigatie zijn?
    - Vind je dit een realistisch scenario?
- Zou jou voorkeur naar een herbruikbaar of wegwerp bakje gaan?
  - Welke voor en nadelen zitten er volgens jou aan het hergebruik?
  - Welke collega's hebben mogelijk een sterke voorkeur voor, of tegen een herbruikbaar opvangbakje?
    - Welke bezwaren zouden zij hebben tegen hergebruik van het bakje?
- Denk je dat, met één of meer van deze aanpassingen het risico op residu weefsel voldoende verlaagd kan worden kan worden?
- Denk je dat, met één of meer van deze aanpassingen het risico op infecties voldoende verlaagd kan worden kan worden?
- Denk je dat het risico bestaat, dat wanneer alle onderdelen die in aanraking komen met een poliep worden vervangen na elke patiënt, het nog steeds kan gebeuren dat overgebleven weefsel van de voorgaande patiënt het weefsel van de nieuwe patiënt kan besmetten, en op deze manier voor een vals positieve uitslag kan zorgen?

- Zijn er nog andere risico's die bij hergebruik komen kijken?
- Heb je zelf nog ideeën om het hergebruik van het poliep opvangbakje mogelijk te maken.
- Is één dag een logische tijdsspanne voor hergebruik van het poliep opvangbakje?  
Optimalisatie
- Zou de kleinere container kunnen leiden tot overstroming van het bakje en spatgevaar?
- Hoe beïnvloed een kleinere maat van de lade de functie en het gebruik van het poliep opvangbakje?
  - Hoe beïnvloed een kleinere maat van de lade de betrouwbaarheid van het poliep opvangbakje?
    - Zou een outlet aan de zijkant een lekrisico kunnen veroorzaken?
    - Zou een outlet aan de zijkant consequenties hebben voor je gevoel van hygiëne en veiligheid tijdens het gebruik?
  - Zie je nog risico's of obstakels die ik over het hoofd heb gezien?
  - Zie je nog mogelijkheden of heb je ideeën voor aanpassingen?
  - Welke belanghebbenden zou ik volgens jou nog moeten spreken?

# F. Cost price calculations

Silicone tube

Price per unit [€]	unit [m]	unit per polyp trap	price per polyp trap [€]	reference
77,04	50	0,08	0,123264	<a href="https://rubberfabriek.be/silicone-slangen/183-258-silicone-slang-fda-ec19332804/">https://rubberfabriek.be/silicone-slangen/183-258-silicone-slang-fda-ec19332804/</a>
195	50	0,08	0,312	<a href="https://www.rubbermagazijn.nl/siliconen-slang-transparant-7x10mm-l-50m-transp">https://www.rubbermagazijn.nl/siliconen-slang-transparant-7x10mm-l-50m-transp</a>
3,66	1	0,08	0,2928	<a href="https://www.flexibeleslangen.nl/brevosil-zi-transparant-4-tot-en-met-8-mm-inwendig/">https://www.flexibeleslangen.nl/brevosil-zi-transparant-4-tot-en-met-8-mm-inwendig/</a>
<b>Average price [€]</b>			<b>0,242688</b>	

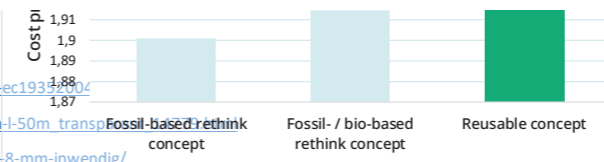

LDPE bag 25\*17 cm

Price per unit [€]	unit [pieces]	unit per polyp trap	price per polyp trap [€]	reference
17,19	1000	1	0,01719	<a href="https://www.bradaverpakkingen.nl/en/ldpe-flat-bag-20my-transparant-format-14-2-x-4-x-2.html">https://www.bradaverpakkingen.nl/en/ldpe-flat-bag-20my-transparant-format-14-2-x-4-x-2.html</a>
24,5	1000	1	0,0245	<a href="https://www.deverpakkingwinkel.com/en_US/p/bag-rib-seal-bag-ldpe-15x20cm-50my-transparent/310/">https://www.deverpakkingwinkel.com/en_US/p/bag-rib-seal-bag-ldpe-15x20cm-50my-transparent/310/</a>
15,34	1000	1	0,01534	<a href="https://eurofolie.nl/Zak-ldpe-transparant-los-160-x-240-mm-40-my/1201009">https://eurofolie.nl/Zak-ldpe-transparant-los-160-x-240-mm-40-my/1201009</a>
<b>Average price [€]</b>			<b>0,01901</b>	

Label

Price per unit [€]	unit [pieces]	unit per polyp trap	price per polyp trap [€]	reference
87,34	999	1	0,087427427	<a href="https://nl.rs-online.com/web/p/pre-printed-labels/0494534?cm_mmc=NL-PLA-DS3A--google--CSS_NL_EN_Computing_%26_Peripherals_Whoop--(NL:Whoop!)+Pre-printed+Labels--4945">https://nl.rs-online.com/web/p/pre-printed-labels/0494534?cm_mmc=NL-PLA-DS3A--google--CSS_NL_EN_Computing_%26_Peripherals_Whoop--(NL:Whoop!)+Pre-printed+Labels--4945</a>
110,15	1000	1	0,11015	<a href="https://unieketiket.nl/#thecalc">https://unieketiket.nl/#thecalc</a>
146,43	1000	1	0,14643	<a href="https://www.pixartprinting.nl/printen-etiketten-labels/stickers-rol/papieren-etiketten/">https://www.pixartprinting.nl/printen-etiketten-labels/stickers-rol/papieren-etiketten/</a>
<b>Average price [€]</b>			<b>0,114669142</b>	

## Manufacturing costs rethink concept

Components	Mould costs [€]	number of components	Processing costs per component [€]	Processing costs per total [€]	Mould costs [€]	Total cost [€]	Estimation H&P Mou	Refence
Container	11.043	1	0,102714047	0,102714047	0,230954828	0,333668875		
Window	7.826	1	0,102714047	0,102714047	0,163665052	0,266379099		
Drawer	11.043	2	0,102714047	0,205428095	0,230954828	0,436382922		
Gasket	920,25	1	0,102714047	0,102714047	0,019246236	0,121960283		
<b>Total price [€]</b>	<b>30.832</b>		<b>#NAAM?</b>	<b>0,513570237</b>	<b>0,644820943</b>	<b>1,15839118</b>	<b>1,25</b>	<a href="https://rexplastics.com/plastic-injection-molds/how-n">https://rexplastics.com/plastic-injection-molds/how-n</a>

## Manufacturing costs reuse concept base kit

Components	Mould costs [€]	number of components	Processing costs per component [€]	Processing costs per total [€]	Mould costs [€]	Total cost [€]
Container	11043	1	0,102714047	0,102714047	1,247156069	1,349870117
Window	3912,785	1	0,102714047	0,102714047	0,441895641	0,544609688
Drawer	5521,5	2	0,102714047	0,205428095	0,623578035	0,829006129
Lid	5521,5	1	0,102714047	0,102714047	0,623578035	0,726292082
Drawer gasket	920,25	1	0,102714047	0,102714047	0,103929672	0,20664372
Window gasket	920,25	1	0,102714047	0,102714047	0,103929672	0,20664372
<b>Total price</b>	<b>27839,285</b>			<b>0,718998331</b>	<b>3,144067124</b>	<b>3,863065456</b>

## Manufacturing costs reuse supplementary kit

Components	Mould costs [€]	number of components	Processing costs per component [€]	Processing costs per total [€]	Mould costs [€]	Total cost [€]
Window	3912,785	1	0,102714047	0,102714047	0,100430827	0,203144875
Drawer	5521,5	2	0,102714047	0,205428095	0,141722281	0,347150375
<b>Total price</b>	<b>9434,285</b>			<b>0,308142142</b>	<b>0,242153108</b>	<b>0,55029525</b>

## Expected annual sales

Annual sales meditec	95629,09
Expected percentage of concept sales	50%
Expected concept sales	47814,545
Expected sales rethink concept	47814,545
Expexted sales reuse concept   Base kit	8854,54537
Expexted sales reuse concept   supplementary kit	38959,99963
Investment recovery timespan [years]	1

